

V2.2 2026-05-25

# Commercial and Industrial Smart Inverter

## ET Series 12-30kW

- Lynx C Series Commercial and Industrial Battery 60kWh
- BAT-C Series Commercial and Industrial Battery 61.4-112.6kWh
- BAT-S Series High-Voltage Battery 15.3-56.3kWh

## Solutions Manual

**GOODWE**

# Copyright Statement

## Copyright Statement

**Copyright© GoodWe Technologies Co., Ltd. 2026. All rights reserved.**

No part of this manual may be reproduced, disseminated, or uploaded to public networks or other third-party platforms in any form without the authorization of GoodWe Technologies Co., Ltd.

## **Trademark Authorization**

**GOODWE** and other GOODWE trademarks used in this manual are the property of GoodWe Technologies Co., Ltd. All other trademarks or registered trademarks mentioned in this manual are the property of their respective owners.

## **NOTICE**

Due to product version upgrades or other reasons, the content of this document may be updated periodically. Unless otherwise agreed, the content of this document cannot replace the safety precautions on the product label. All descriptions in this document are for guidance only.

# About This Manual

## Overview

This document primarily introduces the product information, installation wiring, configuration and commissioning, troubleshooting, and maintenance of the energy storage system composed of inverters, Battery system, and smart meters. Please read this manual carefully before installing and using the product to understand the product safety information and familiarize yourself with the product's functions and features. The document may be updated periodically. Please obtain the latest version of the materials and more product information from the official website.

## Applicable Model

The energy storage system includes the following products:

Product Type	Product Information	Description
Inverter	ET 12-30kW	Nominal output power 12kW to 30kW.
Battery system	Lynx C Series 60kWh Commercial & Industrial Battery System	Single cluster storage capacity 60kWh. Maximum parallel cluster storage capacity up to 180kWh.
	BAT-S Series 15.3-56.3kWh High Voltage Battery	Single cluster storage capacity 15.3/20.4/25.6/30.7/35.8/40.9/46.0/51.2/56.3 kWh. Maximum parallel cluster storage capacity up to 91.8/122.4/153.6/184.2/214.8/245.4/276.0/307.2/337.8 kWh.

Product Type	Product Information	Description
	BAT-C Series 61.4-112.6kWh Commercial & Industrial Battery System	Single cluster storage capacity 61.4/92.1/102.4/112.6kWh.
Meter	GM3000	Monitoring module in the energy storage system, capable of detecting operating voltage, current, and other information within the system.
	GM330	
	GMK330	
Smart Dongle	WiFi/LAN Kit-20	Can upload system operation information to the monitoring platform via WiFi or LAN signal.
	LS4G Kit-CN, 4G Kit-CN, 4G Kit-CN-G20 or 4G Kit-CN-G21 (China only)	Can upload system operation information to the monitoring platform via 4G signal.
	Wi-Fi Kit	Can upload system operation information to the monitoring platform via WiFi signal.
	Ezlink3000	Connected to the main inverter in parallel operation scenarios. Can upload system operation information to the monitoring platform via WiFi or LAN signal.

## Symbol Definition

 DANGER

Indicates a situation with a high potential hazard, which, if not avoided, will result in death or serious injury.

 WARNING

Indicates a situation with a moderate potential hazard, which, if not avoided, could result in death or serious injury.

 CAUTION

Indicates a situation with a low potential hazard, which, if not avoided, could result in moderate or minor injury.

NOTICE

Emphasizes or supplements content, and may also provide tips or tricks for optimal product use, helping you solve a problem or save time.

## Table of Contents

1 Safety Precautions	12
1.1 General Safety	12
1.2 personnel requirements	12
1.3 System Safety	13
1.3.1 PV String Safety	15
1.3.2 Inverter Safety	16
1.3.3 Battery Safety	17
1.3.4 Smart Meter Safety	19
1.4 Safety Symbols and Certification Marks	20
1.5 EU Declaration of Conformity	21
1.5.1 Equipment with Wireless Communication Modules	21
1.5.2 Equipment without Wireless Communication Modules (Except Battery)	22
1.5.3 Battery	22
2 System Introduction	24
2.1 System Overview	24
2.2 Product Overview	29
2.2.1 Inverter	29
2.2.2 Battery	31
2.2.2.1 Lynx C Series 60kWh Commercial & Industrial Battery System	32
2.2.2.2 BAT-S Series 15.3–56.3kWh High-Voltage Battery	33
2.2.2.3 BAT Series 61.4–112.6kWh Commercial & Industrial Battery System	37

2.2.3 Smart Meter	47
2.2.4 Smart Dongle	48
2.3 Supported Grid Types	49
2.4 System Working Mode	50
2.5 Features	60
3 Check and Storage	64
3.1 Check Before Receiving	64
3.2 deliverables	64
3.2.1 Inverter Deliverables	64
3.2.2 Batteries Deliverables	67
3.2.2.1 Lynx C Series 60kWh Commercial & Industrial Battery System	67
3.2.2.2 BAT-S Series 15.3-56.3kWh High Voltage Battery	71
3.2.2.3 BAT Series 61.4-112.6kWh Commercial & Industrial Battery System	75
3.2.3 Smart Meter Deliverables (GM3000)	76
3.2.4 Smart Meter Deliverables GM330&GMK330	77
3.2.4.1 Accessory List	77
3.3 Storage	78
4 Installation	80
4.1 System Installation and Commissioning Procedure	80
4.2 Installation Requirements	81
4.2.1 Installation Environment Requirements	81
4.2.2 Installation Foundation Requirements	84

4.2.3 Installation Space Requirements	85
4.2.4 Tool Requirements	87
4.3 Equipment Handling	89
4.4 Installing the Inverter	93
4.5 Installing the Battery System	97
4.5.1 Open the Cabinet Door	97
4.5.2 Installing the Lynx C-Series 60kWh Commercial & Industrial Battery System	98
4.5.3 Installing the BAT-S-Series 15.3-56.3kWh High Voltage Battery	99
4.5.4 Installing the BAT-Series 61.4-112.6kWh Commercial & Industrial Battery System	103
4.6 Installing the Smart Meter	105
5 System Wirings	107
5.1 System Wiring Electrical Block Diagram	107
5.2 Detailed System Wiring Diagram	110
5.2.1 Detailed System Wiring Diagram for Single Inverter	111
5.2.2 Detailed System Wiring Diagram for Parallel System	116
5.3 Preparing Materials	116
5.3.1 Preparing Breakers	117
5.3.2 Preparing Cables	121
5.3.3 Removing the Baffle	124
5.4 Connecting the PE cable	126
5.4.1 Inverter Grounding	127

5.4.2 Battery System Grounding	127
5.5 Connecting the PV Cable	128
5.6 Connecting the Battery System Cables	130
5.6.1 With Lynx C-Series 60kWh Commercial & Industrial Battery System	134
5.6.1.1 Battery Cable Entry Port Introduction	134
5.6.1.2 Connecting the Power Cable between the Inverter and Battery	135
5.6.1.3 Connecting the Battery Communication Cable	139
5.6.1.4 Connecting the Internal Power Busbars of the Battery System	141
5.6.1.5 Connecting the Power Cable for the Battery System Air Conditioner	142
5.6.1.6 Connecting the Drain Pipe for the Battery System Air Conditioner	143
5.6.1.7 Turning On the Fire Protection Switch	143
5.6.1.8 Installing the Cover Plate	145
5.6.2 With BAT-S Series 15.3-56.3kWh High-Voltage Battery	145
5.6.2.1 Connecting the Power Cable between the Inverter and Battery	146
5.6.2.2 Connecting Power Cables between Battery Packs	149
5.6.2.3 Connecting the Communication Cable	149
5.6.3 With BAT Series 61.4-112.6kWh Commercial & Industrial Battery System	151
5.6.3.1 Battery Cable Entry Ports and System Wiring Introduction	152
5.6.3.2 Connecting the Power Cable between the Inverter and Battery	153
5.6.3.3 Connecting the Battery Communication Cable	154
5.6.3.4 Connecting the Battery Air Conditioning Cable	156

5.6.3.5 Installing the Base Plate and Releasing the Emergency Stop Switch	157
5.7 Connecting the AC Cable	157
5.8 Connecting the Meter Cable	159
5.9 Connecting the Inverter Communication Cable	163
5.10 Connecting the Smart Dongle	170
6 System Commissioning	173
6.1 Check Before Power ON	173
6.2 Power ON	173
6.3 Indicators	175
6.3.1 Inverter Indicators	175
6.3.2 Battery Indicators	176
6.3.3 Smart Meter Indicator	178
6.3.4 Smart Dongle Indicator	179
6.4 Closing the Cabinet Door	183
7 System Commissioning and Power Station Monitoring	185
7.1 Setting Inverter Parameters via App	185
7.2 Setting Inverter Parameters via App	185
7.2.1 Downloading and Installing the SEMS+ App	186
7.3 Monitoring the Power Plant via SEMS+ WEB	186
8 Maintenance	188
8.1 Power OFF the System	188

8.2 Removing the Equipment	189
8.3 Disposing of the Equipment	190
8.4 Routine Maintenance	190
8.5 fault	190
8.5.1 Viewing Fault/Alarms Information	190
8.5.2 Fault Information and Troubleshooting	191
8.5.2.1 System Fault	191
8.5.2.2 Inverter Fault	192
8.5.2.2.1 Troubleshooting (Fault Codes F01-F40)	192
8.5.2.2.2 Troubleshooting (Fault Codes F41-F80)	209
8.5.2.2.3 Troubleshooting (Fault Codes F81-F121)	218
8.5.2.2.4 Troubleshooting (Fault Codes F122-F163)	230
8.5.2.2.5 Troubleshooting for Fault Phenomena	238
8.5.2.3 Battery fault	257
8.5.3 Post-fault Clearance Handling	270
8.5.3.1 Clear AFCI Fault Warning	270
9 technical parameter	272
9.1 Inverter Parameters	272
9.2 Battery Parameters	287
9.3 Smart Meter Technical Data	287
9.3.1 GM330	287
9.3.2 GM3000	288

9.3.3 GMK330	289
9.4 Smart Dongle Technical Data	291
9.4.1 4G Kit-CN-G21	291
9.4.2 4G Kit-CN-G20	292
9.4.3 WiFi/LAN Kit-20	293
9.4.4 Ezlink3000	294
10 Appendix	295
10.1 FAQ	295
10.1.1 How to conduct auxiliary detection for smart meters/CT?	295
10.1.2 How to Upgrade the Device Version	295
10.2 Abbreviations	296
10.3 Explanation of Terms	299
10.4 Battery SN Code Meaning	300
10.5 Safety Standards Countries	301
11 Contact Details (Overseas Version)	308

# 1 Safety Precautions

Please always adhere to the safety precaution information contained in this document when operating the equipment.

## WARNING

The device has been strictly designed and tested in compliance with safety regulations. However, as electrical equipment, relevant safety instructions must be followed before performing any operations on the device. Improper operation may lead to serious injury or property damage.

## 1.1 General Safety

### NOTICE

- Due to product version upgrades or other reasons, the document content will be updated periodically. Unless otherwise agreed, the document content cannot replace the safety precautions on product labels. All descriptions in the document are for guidance only.
- Please read this document carefully before installing the device to understand the product and precautions.
- All operations of the device must be performed by professional and qualified electrical technicians who are familiar with the relevant standards and safety regulations at the project location.
- When operating the device, use insulated tools and wear personal protective equipment to ensure personal safety. When handling electronic components, wear anti-static gloves, anti-static wrist straps, anti-static clothing, etc., to protect the device from electrostatic damage.
- Unauthorized disassembly or modification may cause device damage, and such damage is not covered by the warranty.
- Device damage or personal injury caused by not following the installation, use, or configuration requirements in this document or the corresponding user manual is beyond the manufacturer's liability. For more product warranty information, please visit the official website: <https://en.goodwe.com/warrantyrelated.html>.

## 1.2 personnel requirements

### NOTICE

To ensure safety, compliance, and efficiency throughout the entire process of equipment transportation, installation, wiring, operation, and maintenance, all tasks must be performed by professionals or qualified personnel.

1. Professionals or qualified personnel include:
  - Personnel who have mastered knowledge of equipment working principles, system structure, risks and hazards, and have received professional operation training or possess extensive practical experience.
  - Personnel who have received relevant technical and safety training, possess certain operational experience, can recognize the potential dangers of specific tasks to themselves, and can take protective measures to minimize risks to themselves and others.
  - Qualified electrical technicians who meet the regulatory requirements of the country/region where they are located.
  - Personnel holding a degree in electrical engineering/an advanced diploma in electrical discipline or equivalent/professional qualifications in the electrical field, and possessing at least 2/3/4 years of experience in testing and regulatory work using electrical equipment safety standards.
2. Personnel involved in special tasks such as electrical work, work at heights, and special equipment operation must hold valid qualification certificates required by the location of the equipment.
3. Operation of medium-voltage equipment must be performed by certified high-voltage electricians.
4. Replacement of equipment and components is only permitted to be performed by authorized personnel.

## 1.3 System Safety



- Before making electrical connections, disconnect all upstream switches of the equipment to ensure the equipment is powered off. Live operation is strictly prohibited, otherwise hazards such as electric shock may occur.
- To prevent personal injury or equipment damage caused by live operation, a circuit breaker must be added to the voltage input side of the equipment.
- All operations, including transportation, storage, installation, operation, use, and maintenance, must comply with applicable laws, regulations, standards, and specifications.
- The specifications of cables and components used for electrical connections must comply with local laws, regulations, standards, and specifications.
- Please use the cable connectors provided in the package to connect equipment cables. If other models of connectors are used, any resulting equipment damage is not within the manufacturer's responsibility.
- Ensure all equipment cable connections are correct, secure, and not loose. Improper wiring may cause poor contact or damage the equipment.
- The equipment's protective ground wire must be securely connected.
- To protect the equipment and its components from damage during transportation, ensure transport personnel are professionally trained. Record operational steps during transportation and keep the equipment balanced to avoid dropping.
- The equipment is heavy. Please assign personnel according to the equipment's weight to prevent it from exceeding the human handling capacity and causing injury.
- Ensure the equipment is placed stably and not tilted. Equipment tipping may cause equipment damage and personal injury.



- During equipment installation, avoid placing weight on the wiring terminals, otherwise the terminals may be damaged.
- If the cable is subjected to excessive tension, poor connections may result. When wiring, leave a certain length of cable slack before connecting it to the equipment's terminal ports.
- Cables of the same type should be bundled together. Cables of different types should be routed at least 30mm apart, and interweaving or crossing of cables is prohibited.
- Using cables in high-temperature environments may cause insulation aging or damage. Maintain a distance of at least 30mm between cables and heating components or the periphery of heat source areas.

### **1.3.1 PV String Safety**

## WARNING

- Ensure the component frame and mounting system are properly grounded.
- After connecting the DC cables, ensure the connections are tight and secure with no looseness. Improper wiring may lead to poor contact or high impedance, and damage the inverter.
- Use a multimeter to measure the positive and negative poles of the DC cables to ensure correct polarity (no reverse connection) and that the voltage is within the allowable range.
- Use a multimeter to measure the DC cables to ensure correct polarity (no reverse connection); the voltage should be lower than the maximum DC input voltage. Damage caused by reverse connection and overvoltage is not covered by the equipment manufacturer's warranty.
- The PV string output does not support grounding. Before connecting the PV string to the inverter, ensure the minimum insulation resistance to ground of the PV string meets the minimum insulation impedance requirement ( $R = \text{Max. Input Voltage (V)} / 30\text{mA}$ ).
- Do not connect the same PV string to multiple inverters, as this may cause inverter damage.
- The PV modules used with the inverter must comply with IEC 61730 Class A standards.
- When the PV string input voltage or input current is high, it may cause the inverter output power to derate.

### 1.3.2 Inverter Safety

## WARNING

- Ensure that the voltage and frequency at the grid connection point comply with the inverter's grid connection specifications.
- It is recommended to add protective devices such as circuit breakers or fuses on the AC side of the inverter. The specification of the protective device should be greater than 1.25 times the maximum AC output current of the inverter.
- If the inverter triggers an arc fault alarm less than 5 times within 24 hours, the alarm can be automatically cleared. After the 5th arc fault alarm, the inverter will shut down for protection. The inverter can only resume normal operation after the fault is cleared.
- If no battery is configured in the photovoltaic system, it is not recommended to use the BACK-UP function, as it may cause system power outage risks.
- Changes in grid voltage and frequency may cause the inverter output power to derate.

### 1.3.3 Battery Safety

## DANGER

- Before operating any equipment in the system, ensure the equipment is powered off to avoid the risk of electric shock. Strictly adhere to all safety precautions in this manual and the safety labels on the equipment during operation.
- Do not disassemble, modify, or repair the battery or control box without official authorization from the equipment manufacturer, as this may pose an electric shock hazard or cause equipment damage. Losses resulting from such actions are beyond the manufacturer's liability.
- Do not impact, pull, drag, squeeze, or step on the equipment, and do not place the battery in a fire, as this may cause the battery to explode.
- Do not place the battery in a high-temperature environment. Ensure there are no heat sources near the battery and that it is not exposed to direct sunlight. A fire may occur if the ambient temperature exceeds 60°C.
- Do not use the battery or control box if there are obvious defects, cracks, damage, or other issues. Battery damage may lead to electrolyte leakage.
- Do not move the battery system while it is in operation. If battery replacement or addition is required, please contact the after-sales service center.
- Battery short circuits may cause personal injury. The instantaneous high current from a short circuit can release a large amount of energy, potentially leading to a fire.
- The battery DC circuit breaker must comply with the requirements of the AS/NZS 5139 standard.

## WARNING

- Battery current may be affected by factors such as temperature, Humidity, weather conditions, etc., which may lead to current limiting and affect load capacity.
- If the battery fails to start, please contact the after-sales service center as soon as possible. Otherwise, the battery may be permanently damaged.
- Please perform regular inspection and maintenance on the battery according to its maintenance requirements.

- Battery electrolyte leakage

If a battery module leaks electrolyte, avoid contact with the leaked liquid or gas. The electrolyte is corrosive and contact may cause skin irritation and chemical burns. If accidental contact with the leaked substance occurs, take the following actions:

- inhalation: Evacuate from the contaminated area and seek medical help immediately.
- Eye contact: Flush with clean water for at least 15 minutes and seek medical help immediately.
- Skin contact: Wash the affected area thoroughly with soap and water and seek medical help immediately.
- Ingestion: Induce vomiting and seek medical assistance immediately.

- Fire

- When the battery temperature exceeds 150°C, there is a risk of fire. A battery fire may release toxic and harmful gases.
- To prevent fire, ensure that carbon dioxide, Novec1230, or FM-200 fire extinguishers are available near the equipment.
- When extinguishing a fire, do not use ABC dry powder extinguishers. Firefighters must wear protective clothing and self-contained breathing apparatus.

- Battery triggers fire protection

For batteries equipped with optional fire protection, after the fire protection function is triggered, perform the following actions:

- Immediately cut off the main power switch to ensure no current flows through the battery system.
- Conduct a preliminary visual inspection of the battery for any damage, deformation, leakage, or unusual odor. Check the battery casing, connectors, and cables.
- Use a temperature sensor to detect the temperature of the battery and its surroundings to ensure there is no risk of overheating.
- Isolate and mark the damaged battery, and dispose of it properly according to local regulations.

### 1.3.4 Smart Meter Safety









## ! WARNING















If the grid voltage fluctuation exceeds 265V, long-term overvoltage operation may damage the meter. It is recommended to add a fuse with a rated current of 0.5A on the voltage input side of the meter to protect it.

## 1.4 Safety Symbols and Certification Marks

### ! DANGER

- After the device is installed, the labels and warning signs on the box must be clearly visible. It is prohibited to block, alter, or damage them.
- The following box warning label descriptions are for reference only. Please refer to the actual labels used on the device.

No.	Symbol	Meaning
1		Potential hazard exists during equipment operation. Take protective measures when operating the equipment.
2		High voltage hazard. High voltage is present during equipment operation. Ensure the equipment is powered off before performing any operations.
3		The inverter surface is at high temperature. Do not touch during operation to avoid burns.
4		Use the equipment properly. Use under extreme conditions carries a risk of explosion.
5		The battery contains flammable materials. Beware of fire.
6		The equipment contains corrosive electrolyte. Avoid contact with leaked electrolyte or its vapors.
7		Delayed discharge. After powering off the equipment, wait for 5 minutes for it to discharge completely.
8		Keep the equipment away from open flames or ignition sources.

No.	Symbol	Meaning
9		Keep the equipment out of reach of children.
10		Use the equipment properly. Use under extreme conditions carries a risk of explosion.
11		The battery contains flammable materials. Beware of fire.
12		Do not lift the equipment after the battery system wiring is completed or while the battery system is operating.
13		Do not extinguish with water.
14		Read the product manual carefully before operating the equipment.
15		Personal protective equipment must be worn during installation, operation, and maintenance.
16		This equipment must not be disposed of as household waste. Dispose of it according to local laws and regulations, or return it to the equipment manufacturer.
17		Do not directly disconnect or plug/unplug the DC terminals while the equipment is operating.
18		Grounding point.
19		Recycling symbol.
20		CE certification mark.
21		TUV mark.
22		RCM mark.

## 1.5 EU Declaration of Conformity

### **1.5.1 Equipment with Wireless Communication Modules**

Equipment with wireless communication modules sold in the European market must comply with the following directives:

- Radio Equipment Directive 2014/53/EU (RED)
- Restrictions of Hazardous Substances Directive 2011/65/EU and (EU) 2015/863 (RoHS)
- Waste Electrical and Electronic Equipment 2012/19/EU
- Registration, Evaluation, Authorization and Restriction of Chemicals (EC) No 1907/2006 (REACH)

### **1.5.2 Equipment without Wireless Communication Modules (Except Battery)**

Equipment without Wireless Communication Modules (Except Battery) that can be sold in the European market meets the following directive requirements:

- Electromagnetic compatibility Directive 2014/30/EU (EMC)
- Electrical Apparatus Low Voltage Directive 2014/35/EU (LVD)
- Restrictions of Hazardous Substances Directive 2011/65/EU and (EU) 2015/863 (RoHS)
- Waste Electrical and Electronic Equipment 2012/19/EU
- Registration, Evaluation, Authorization and Restriction of Chemicals (EC) No 1907/2006 (REACH)

### **1.5.3 Battery**

Batteries that can be sold in the European market meet the requirements of the following directives:

- Electromagnetic compatibility Directive 2014/30/EU (EMC)
- Electrical Apparatus Low Voltage Directive 2014/35/EU (LVD)
- Restrictions of Hazardous Substances Directive 2011/65/EU and (EU) 2015/863 (RoHS)\*<sup>1</sup>
- Regulation (EU) 2023/1542 Article 12 - Safety of stationary battery energy storage systems
- Regulation (EU) 2023/1542 Article 10 - Performance and durability requirements

for rechargeable industrial batteries, LMT batteries and electric vehicle batteries

- Regulation (EU) 2023/1542 Article 14 - Information on the state of health and expected lifetime of batteries
- Waste Electrical and Electronic Equipment 2012/19/EU
- Registration, Evaluation, Authorization and Restriction of Chemicals (EC) No 1907/2006 (REACH)

\*1: Our company's battery products meet the hazardous substance limit requirements stipulated by this regulation.

More EU Declarations of Conformity can be obtained from the [official website](#).

# 2 System Introduction

## 2.1 System Overview

The industrial and commercial smart inverter solution integrates devices such as inverters, Battery, Smart Meter, and smart communication sticks. In a photovoltaic system, it converts solar energy into electricity to meet industrial and commercial power demands. The energy IoT devices in the system identify the overall power situation to manage electrical equipment, thereby intelligently managing power for use by loads, storage in the Battery, or export to the grid.

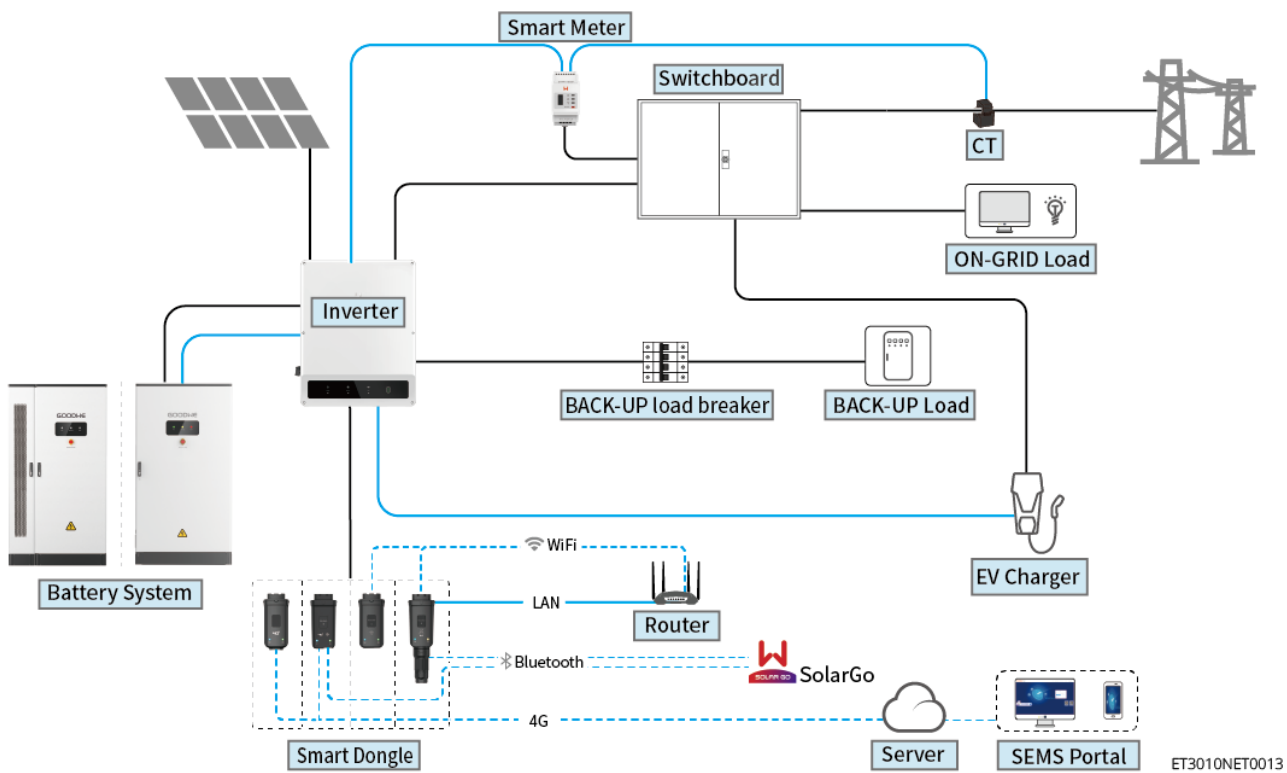
### WARNING

- Select the battery model according to the inverter and battery compatibility list. For requirements on batteries used in the same system, such as whether models can be mixed or whether capacities must be consistent, please refer to the user manual of the corresponding battery model or contact the battery manufacturer for relevant requirements. Inverter and battery compatibility list: [https://en.goodwe.com/Ftp/EN/Downloads/User%20Manual/GW\\_Battery%20Compatibility%20Overview-EN.pdf](https://en.goodwe.com/Ftp/EN/Downloads/User%20Manual/GW_Battery%20Compatibility%20Overview-EN.pdf).
- Due to product version upgrades or other reasons, the document content will be updated periodically. The compatibility between inverters and IoT products can be referred to: [https://en.goodwe.com/Ftp/EN/Downloads/User%20Manual/GW\\_Compatibility-list-of-GoodWe-inverters-and-IoT-products-EN.pdf](https://en.goodwe.com/Ftp/EN/Downloads/User%20Manual/GW_Compatibility-list-of-GoodWe-inverters-and-IoT-products-EN.pdf).
- The photovoltaic system is not suitable for connecting devices that rely on stable power supply, such as life-supporting medical equipment, etc. Ensure that system power failure does not cause personal injury.
- If the photovoltaic system is not configured with a battery, it is not recommended to use the BACK-UP function, otherwise it may cause a system power failure risk.
- The BACK-UP port does not support connection to autotransformers or isolation transformers.
- Battery current may be affected by factors such as temperature, Humidity, weather conditions, etc., which may cause battery current limiting and affect

 **WARNING**

load-carrying capacity.

- The inverter has a UPS function with a switching time of <10ms. Please ensure the BACK-UP Loads capacity is less than the inverter's rated power. Otherwise, the UPS function may fail during a grid power outage.
- If the photovoltaic system is not configured with a battery, it is not recommended to use the BACK-UP function, otherwise it may cause a system power failure risk.
- For detailed networking and wiring schemes for each scenario, please refer to: Detailed System Wiring Diagram.
- When the inverter is in an off-grid state, it can be used normally for common household loads. However, the following loads need to be limited, such as:
  - inductive load: inductive load power < 0.4 times the inverter's rated output power.
  - Capacitive load: total power  $\leq 0.66 \times$  inverter rated output power.
  - The inverter does not support half-wave loads. Half-wave loads: Some old or non-EMC compliant appliances (such as hair dryers, small heaters using half-wave rectification) may not work properly.
- In a system where the inverter operates completely off-grid, if the battery is in low sunlight or rainy weather for a long time and cannot be replenished in time, it may lead to over-discharge, causing battery performance degradation or damage. To ensure long-term stable system operation, avoid completely draining the battery. Recommended measures are as follows:
  - During off-grid operation, set the minimum SOC protection threshold. It is recommended to set the off-grid battery SOC lower limit to 30%.
  - When the SOC approaches the protection threshold, the system will automatically enter load limiting or protection mode.
  - If there is insufficient sunlight for multiple consecutive days and the battery SOC is too low, promptly replenish the battery using external energy sources (such as a generator or grid-assisted charging).
  - Regularly check the battery status to ensure it is within a safe operating range.
  - It is recommended to fully charge and discharge the battery once every six months to calibrate the SOC accuracy.



ET3010NET0013

Device Type	model	Description
Inverter	GW12KL-ET GW18KL-ET GW15K-ET GW20K-ET GW25K-ET GW29.9K-ET GW30K-ET	<ul style="list-style-type: none"> <li>• Supports up to 4 inverters to form a parallel system.</li> <li>• Battery ready models do not support forming a parallel system when the battery function is not activated.</li> <li>• Only machines with the same AC output voltage can form a parallel system.</li> <li>• GW12KL-ET and GW18KL-ET only support the BAT-S Series 15.3kWh-56.3kWh battery. And the following version requirements must be met:               <ul style="list-style-type: none"> <li>◦ Inverter ARM software version 17.449 or above.</li> <li>◦ Inverter DSP software version 13.13011 or above.</li> </ul> </li> <li>• In a coupling scenario, using a dual meter allows simultaneous monitoring of grid-tied inverter generation and load consumption. The following version requirements must be met:               <ul style="list-style-type: none"> <li>◦ Inverter ARM software version 15.441 or above.</li> <li>◦ Inverter DSP software version 11.11060 or above.</li> <li>◦ SolarGo version 6.9.0 or above.</li> </ul> </li> </ul>
Battery system	GW60KWH-D-10 GW60KWH-D-10(No expansion cabinet)	The system supports up to 3 battery system clusters in parallel.

Device Type	model	Description
	GW15.3-BAT-I-G10 GW20.4-BAT-I-G10 GW25.6-BAT-I-G10 GW30.7-BAT-I-G10 GW35.8-BAT-I-G10 GW40.9-BAT-I-G10 GW46.0-BAT-I-G10 GW51.2-BAT-I-G10 GW56.3-BAT-I-G10	<ul style="list-style-type: none"> <li>• Supports up to 6 battery system clusters in parallel.</li> <li>• Different model battery systems cannot be mixed in a parallel cluster.</li> </ul>
	GW61.4-BAT-AC-G10 GW92.1-BAT-AC-G10 GW102.4-BAT-AC-G10 GW112.6-BAT-AC-G10	Supports single cluster only.
Smart Meter	<ul style="list-style-type: none"> <li>• GM3000</li> <li>• GM330</li> <li>• GMK330</li> </ul>	<ul style="list-style-type: none"> <li>• GM3000: Supplied with the inverter. CT cannot be replaced. CT ratio: 120A: 40mA</li> <li>• GM330: CT can be purchased from GoodWe or independently. CT ratio requirement: nA: 5A               <ul style="list-style-type: none"> <li>◦ nA: CT primary side input current, where n ranges from 200 to 5000.</li> <li>◦ 5A: CT secondary side output current.</li> </ul> </li> <li>• GMK330: CT is shipped with the meter. CT ratio:               <ul style="list-style-type: none"> <li>◦ 120A: 40mA</li> <li>◦ 200A: 50mA (Brazil only)</li> </ul> </li> </ul>

Device Type	model	Description
Smart Dongle	<ul style="list-style-type: none"> <li>WiFi/LAN Kit-20</li> <li>Wi-Fi Kit</li> <li>LS4G Kit-CN, 4G Kit-CN, 4G Kit-CN-G20, or 4G Kit-CN-G21 (China only)</li> <li>Ezlink3000</li> </ul>	<ul style="list-style-type: none"> <li>For a single unit, use the WiFi/LAN Kit-20, Wi-Fi Kit, LS4G Kit-CN, 4G Kit-CN, 4G Kit-CN-G20, or 4G Kit-CN-G21 module. If using WiFi/LAN Kit-20 to replace Wi-Fi Kit, please upgrade the inverter ARM firmware version to 08.401 or above before switching to WiFi/LAN Kit-20.</li> <li>In a parallel system, only the master inverter needs to be connected to Ezlink3000; slave inverters do not require a communication module. Ezlink3000 firmware version must be 04 or above.</li> </ul>

## 2.2 Product Overview

### 2.2.1 Inverter

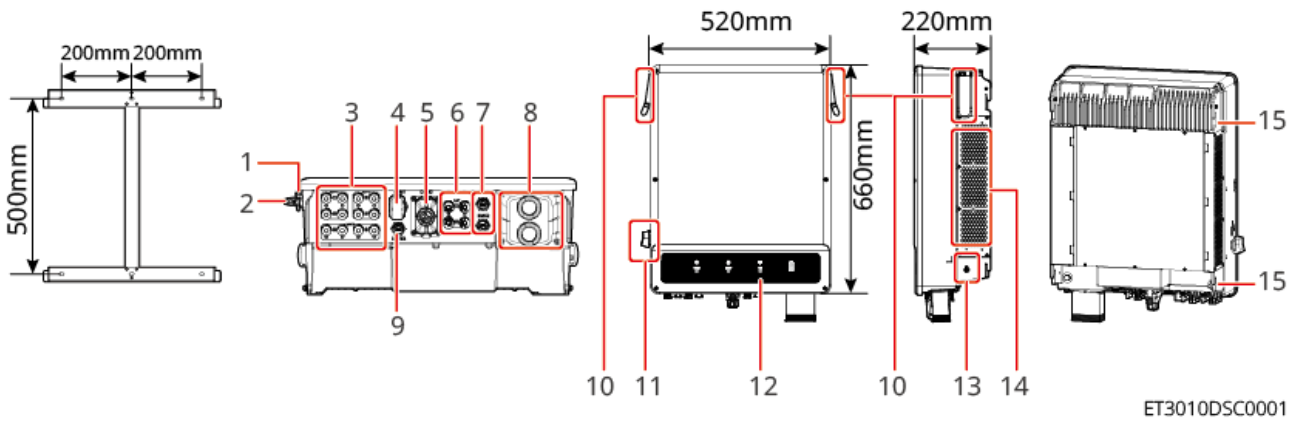
The Inverter in a photovoltaic system controls and optimizes the energy flow through an integrated energy management system. It can supply the electricity generated by the photovoltaic system to the load, store it in the battery, or output it to the grid.

#### NOTICE

The appearance of inverters varies across different power ranges. Please refer to the actual product.

No.	model	Nominal output power	Nominal output voltage	Number of Battery Ports
1	GW12KL-ET	12kW	220V, 3L/N/PE	1
2	GW18KL-ET	18kW		2

No.	model	Nominal output power	Nominal output voltage	Number of Battery Ports
3	GW15K-ET	15kW	380/400V, 3L/N/PE	1
4	GW20K-ET	20kW		1
5	GW25K-ET	25kW		2
6	GW29.9K-ET	29.9kW		2
7	GW30K-ET	30kW		2

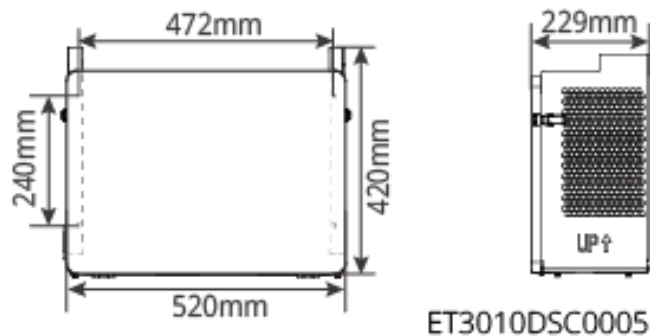


### Component Introduction

No.	Component/Silks creen	Description
1	DC Switch Lock Hole	Australia only.
2	DC Switch	Controls the connection or disconnection of DC input.
3	PV Input Terminal	Can connect to the DC input cables of PV modules. <ul style="list-style-type: none"> <li>• GW15K-ET, GW20K-ET, GW12KL-ET x 2</li> <li>• GW25K-ET, GW29.9K-ET, GW30K-ET, GW18KL-ET x 3</li> </ul>
4	Communication Module Port	Can connect to a communication module, supports connecting 4G, Wi-Fi/LAN modules.

5	Communication Port	Connects the communication cable, supports communication with DRED, Remote Shutdown, Rapid Shutdown, RCR, EMS, and generator.
6	Battery Connection Port	Connects battery DC cables. <ul style="list-style-type: none"> <li>• GW15K-ET, GW20K-ET, GW12KL-ET x 1</li> <li>• GW25K-ET, GW29.9K-ET, GW30K-ET, GW18KL-ET x 2</li> </ul>
7	BMS Communication Port	Connects battery communication cable. <ul style="list-style-type: none"> <li>• GW15K-ET, GW20K-ET, GW12KL-ET x 1</li> <li>• GW25K-ET, GW29.9K-ET, GW30K-ET, GW18KL-ET x 2</li> </ul>
8	AC Port	Connects AC cables, ON-GRID and BACK-UP ports.
9	METER Communication Port	Connects to the smart meter.
10	Handle	For carrying the inverter.
11	indicator	Indicates the working status of the inverter.
12	Grounding terminal	Connects the protective earth wire of the enclosure.
13	Fan	Inverter heat dissipation.
14	Inverter Mounting Slot	For mounting and securing the inverter.

#### Australian Junction Box Dimensions



## 2.2.2 Battery

The battery system consists of a PCU and a PACK.

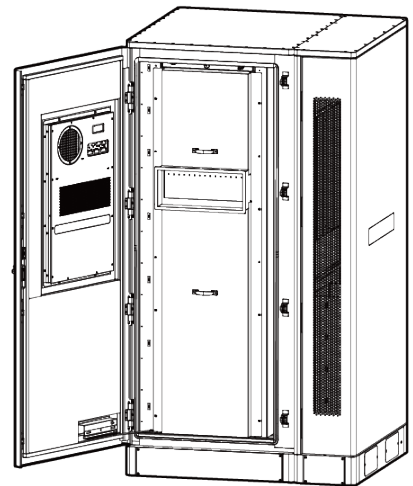
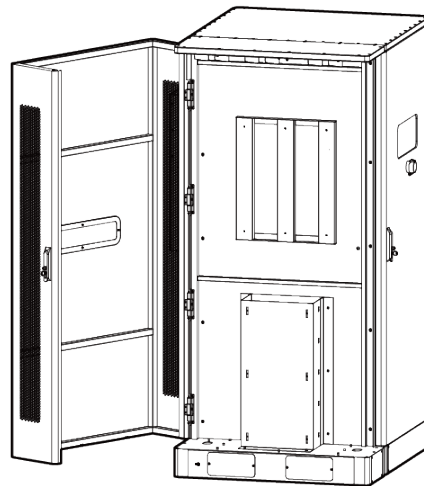
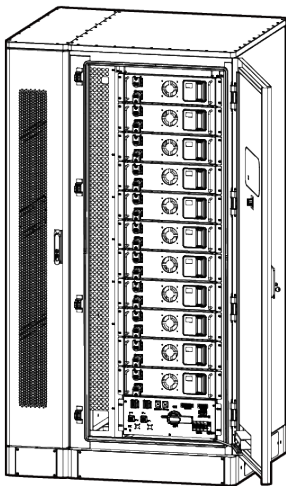
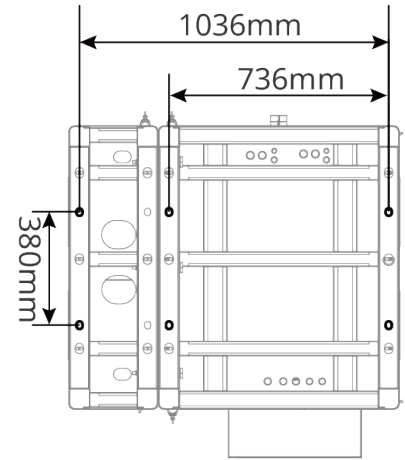
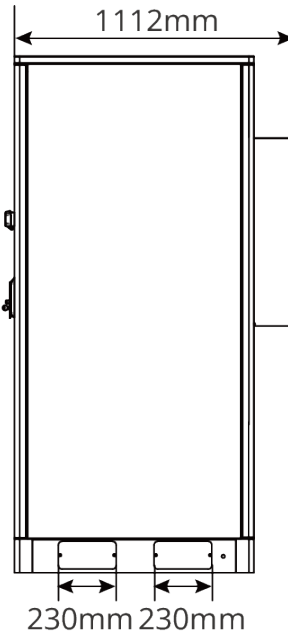
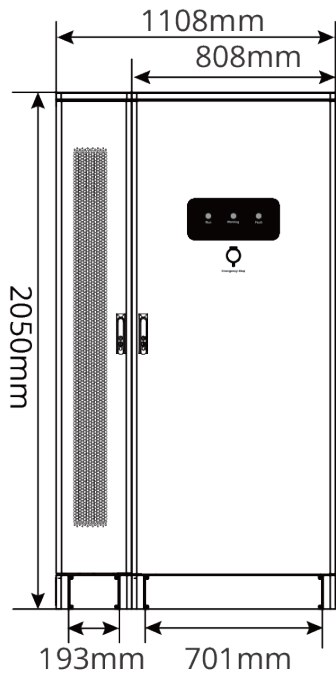
The battery system can store and release electrical energy according to the requirements of the photovoltaic energy storage system. The input and output ports of this energy storage system are both high-voltage direct current.

### NOTICE

- After installation, a single battery cabinet does not support capacity expansion by adding PACKs.
- Within one year after installation, the BAT series battery system can expand clusters by adding battery cabinets of the same model and part number. Please contact after-sales service for details.

### 2.2.2.1 Lynx C Series 60kWh Commercial & Industrial Battery System

No.	model	Rated Capacity (kWh)	Includes AC Cabinet?
1	GW60KWH-D-10	60	Yes
2	GW60KWH-D-10(without expansion cabinet)	60	No



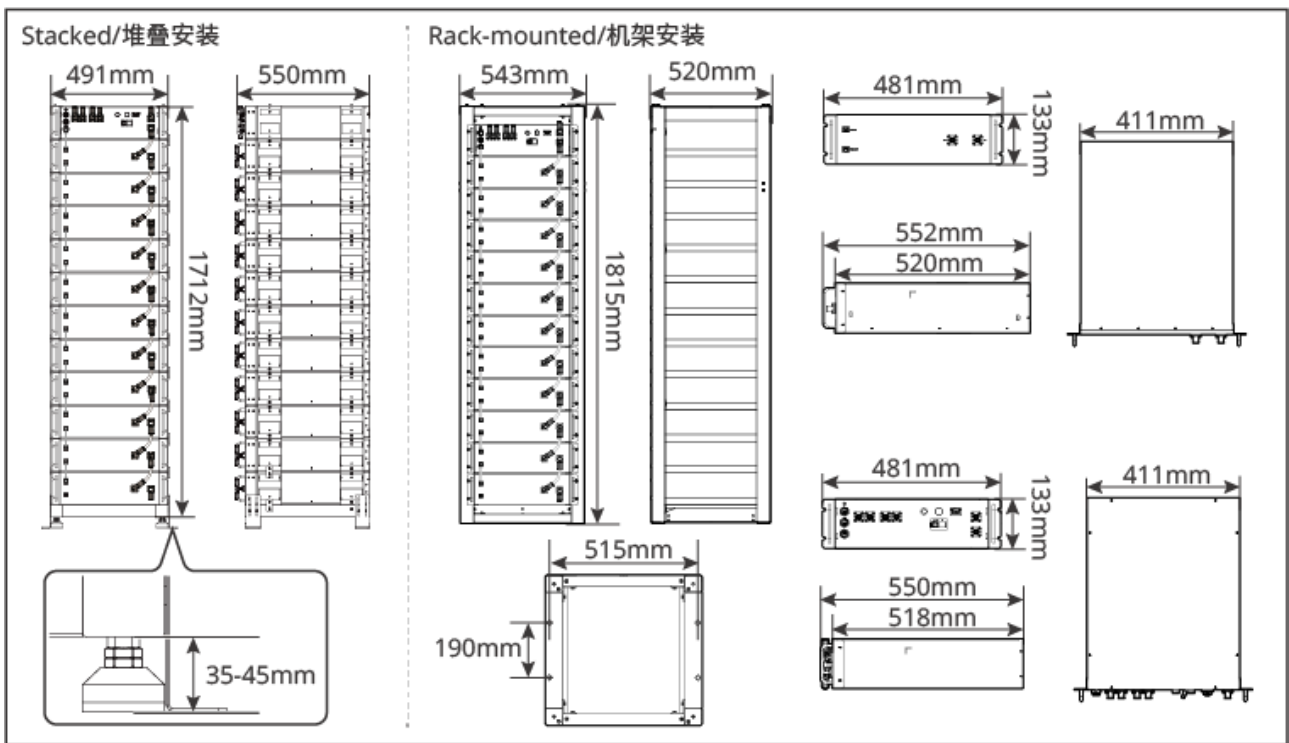
LXC6010DSC0001

### 2.2.2.2 BAT-S Series 15.3-56.3kWh High-Voltage Battery

No.	model	PACK Quantity	Rated Capacity (kWh)
1	GW15.3-BAT-I-G10	3	15.3
2	GW20.4-BAT-I-G10	4	20.4
3	GW25.6-BAT-I-G10	5	25.6
4	GW30.7-BAT-I-G10	6	30.7

No.	model	PACK Quantity	Rated Capacity (kWh)
5	GW35.8-BAT-I-G10	7	35.8
6	GW40.9-BAT-I-G10	8	40.9
7	GW46.0-BAT-I-G10	9	46.0
8	GW51.2-BAT-I-G10	10	51.2
9	GW56.3-BAT-I-G10	11	56.3

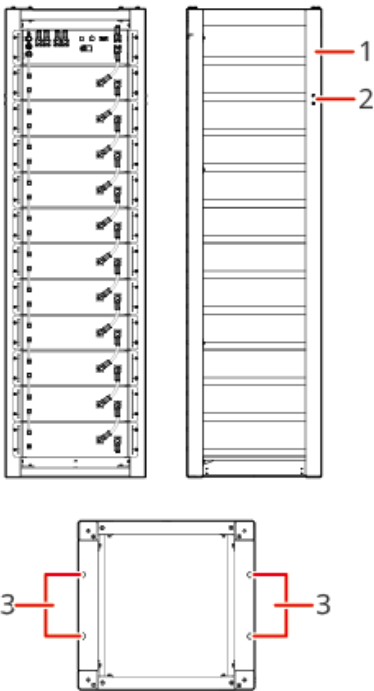
## Dimension Description



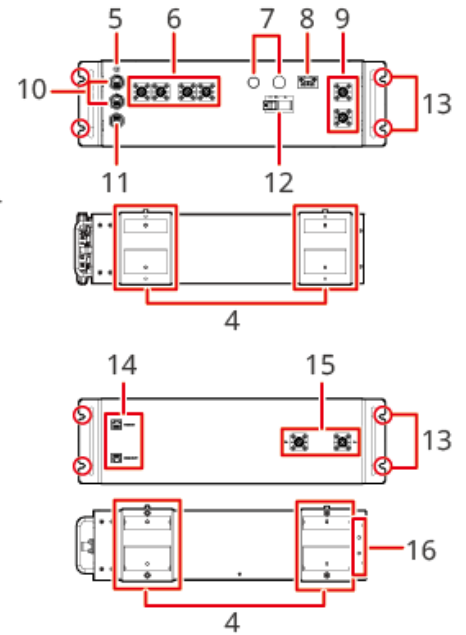
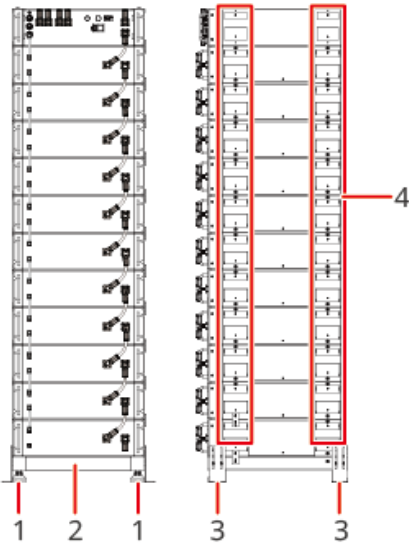
BAT10DSC0007

## Component Introduction

Rack-mounted



Stacked



BAT10DSC0002

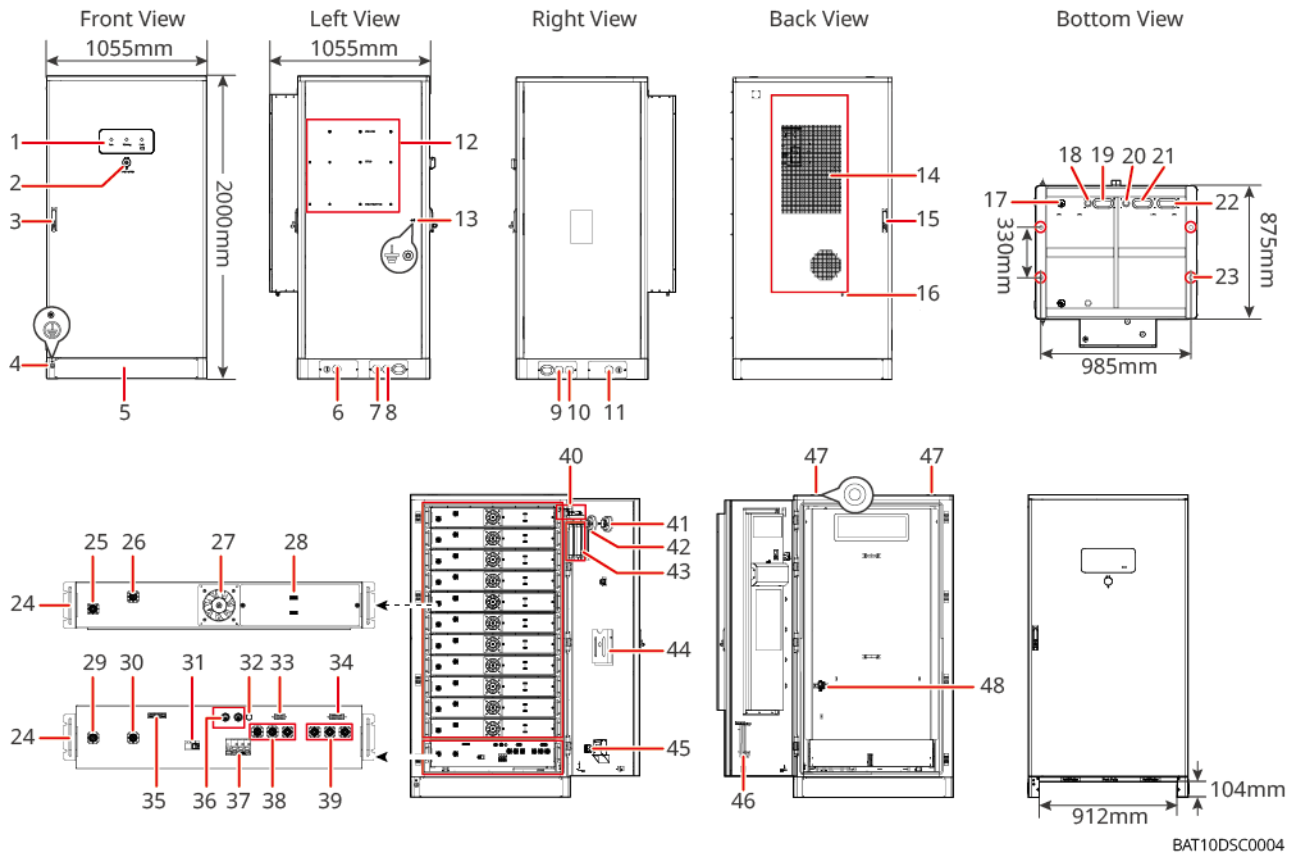
No.	Name	Description
Stack Installation	1	Adjustable Feet Adjustable in height to keep the base level
	2	Base The battery system is stacked and placed on the base
	3	Floor Locking Bracket Used to secure the base to the floor to prevent tipping
	4	Stacking Bracket Fixed on the battery PACK for stacking battery installation
Rack Installation	1	Battery Rack Used for installing the battery system
	2	Wall Locking Bracket Mounting Hole Used to secure the battery rack to the wall to prevent tipping
	3	Floor Locking Bracket Mounting Hole Used to secure the battery rack to the floor to prevent tipping

No.	Name	Description
5	Protective Grounding Point	Used for connecting the ground wire
6	High-Voltage Box Power Input/Output Port 1	Connects the power cable between the high-voltage box and the inverter
7	Battery Indicators	Used to indicate the status of the battery system
8	Dry Contact	Contact for external fire protection system activation (Normally, the dry contact remains open. When a dry contact closure is detected, the battery system will automatically power down.)
9	High-Voltage Box Power Input/Output Port 2	Connects the power cable between the high-voltage box and the battery module
10	External Communication Port	Communicates with the inverter / Places termination resistor / Battery system cluster communication
11	High-Voltage Box Communication Port	Communicates with the battery module
12	Battery System Switch	Controls the start and stop of the battery system
13	High-Voltage Box / Battery PACK Mounting Hole	Used to secure the high-voltage box / battery PACK to the battery rack

No.	Name	Description
14	Battery Module Communication Port	Used for communication between adjacent battery PACKs, and communication between battery PACKs and the high-voltage box
15	Battery Module Power Input/Output Port	Connects the power cable between adjacent battery PACKs
16	Wall Locking Bracket Mounting Hole	Used for installing the wall locking bracket. Only the first and last battery PACKs need to install the wall locking bracket.

### 2.2.2.3 BAT Series 61.4-112.6kWh Commercial & Industrial Battery System

No.	model	PACK Quantity	Rated Capacity (kWh)
1	GW61.4-BAT-AC-G10	6	61.4
2	GW92.1-BAT-AC-G10	9	92.1
3	GW102.4-BAT-AC-G10	10	102.4
4	GW112.6-BAT-AC-G10	11	112.6



BAT10DSC0004

No.	Name	Description
1	LED Indicator	-
2	Emergency Stop Button	Pressing the emergency stop button will power down the battery system.
3	Front Door Lock	-
4	PE Port 1	Connect the battery grounding cable.
5	Bottom Baffle Plate	-
6	Left Entry Port 1	Air conditioner power cable & ET100 power cable
7	Left Entry Port 2	Inverter communication cable
8	Left Entry Port 3	Inverter power cable
9	Right Entry Port 1	Battery cluster-parallel power cable

No.	Name	Description
10	Right Entry Port 2	Battery cluster-parallel communication cable
11	Right Entry Port 3	Air conditioner power cable
12	Back Mounting Plate Installation Hole	Inverter back mounting plate installation hole position
13	PE Port 2	Connect the inverter grounding cable.
14	Air Conditioner	Responsible for temperature control. The air conditioner refrigerant model is R134A.
15	Rear Door Lock	-
16	Air Conditioner Drain Pipe Installation Port	-
17	Explosion-proof Valve	Responsible for explosion-proof, venting, and other functions. When abnormal pressure rise occurs inside the battery system, it quickly and directionally releases internal gas by opening the explosion-proof one-way valve vent port, thereby preventing the battery system from exploding.
18	Communication Cable Entry/Exit Port (Bottom)	Communication cable entry/exit port between the battery and the inverter
19	Power Cable Entry/Exit Port (Bottom)	Power cable entry/exit port between the battery and the inverter
20	Battery Communication Cable Entry/Exit Port	Battery cluster-parallel communication cable entry/exit port
21	Battery Power Cable Entry/Exit Port (Positive)	Battery cluster-parallel power cable entry/exit port (positive)
22	Battery Power Cable Entry/Exit Port (Negative)	Battery cluster-parallel power cable entry/exit port (negative)

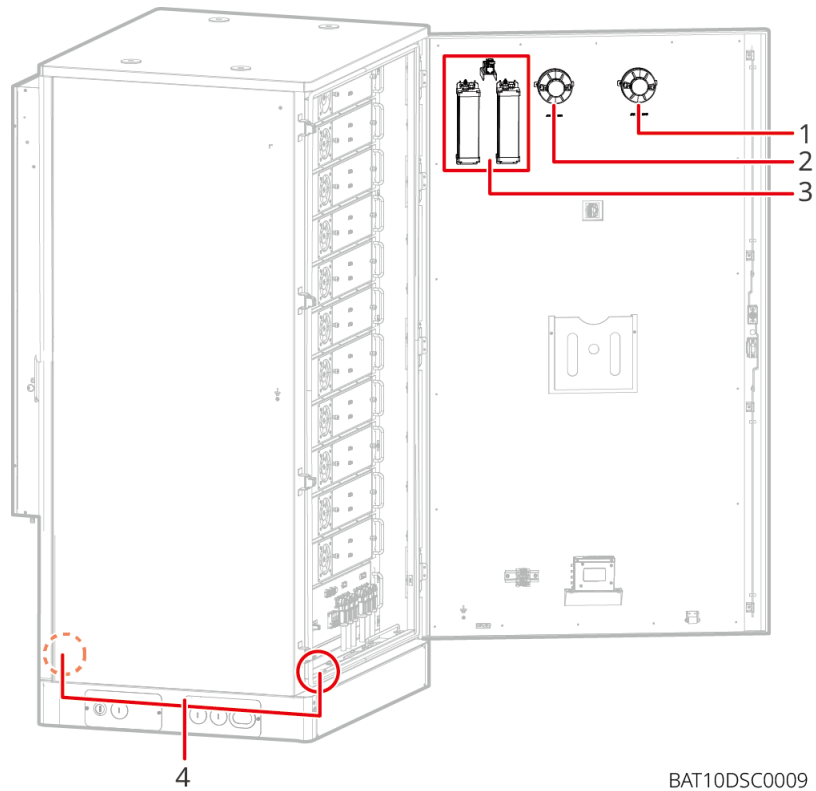
No.	Name	Description
23	Foundation Fixing Hole	Secures the battery system to the foundation from here.
24	Handle	-
25	Battery PACK Power Input/Output Port Positive	-
26	Battery PACK Power Input/Output Port Negative	-
27	Fan	-
28	Battery PACK Communication Port	Communication between adjacent battery PACKs, communication with the high-voltage box, and fan power supply
29	High-voltage Box Power Input/Output Port Negative 1	Connect the power cable between the high-voltage box and the battery PACK.
30	High-voltage Box Power Input/Output Port Positive 1	
31	Molded Case Circuit Breaker (MCCB)	Controls the high-voltage output of the battery system.
32	Black Start Button	Controls the black start of the battery system.
33	Internal Communication Port 1	Communication with battery PACK and battery PACK fan power supply port 1
34	Internal Communication Port 2	Air conditioner communication, access control identification, emergency stop, and fire alarm signal communication port

No.	Name	Description
35	LAN Communication Port	LAN communication between batteries, used for transmitting cell-level information (Only machines shipped after October 2025 support this)
36	External Communication Port 1	Communication with the inverter / placement of terminal resistor / battery system cluster-parallel communication
37	Air Switch	Controls the low-voltage power supply of the battery system.
38	High-voltage Box Power Input/Output Port Positive 2	Connect the power cable between the high-voltage box and the inverter.
39	High-voltage Box Power Input/Output Port Negative 2	Connect the power cable between the high-voltage box and the inverter.
40	Access Control Switch	Automatically disconnects when the door is opened, ensuring the energy storage system is powered off.
41	Heat Detector	<p>The heat detector monitors temperature via a dual thermistor network and outputs a voltage proportional to the external air temperature. One thermistor is exposed to ensure good thermal contact with the surrounding air, while the other is thermally insulated. It emits red light to alert operators when an anomaly is detected.</p> <ul style="list-style-type: none"> <li>• Suitable for environments with dust or smoke under normal conditions.</li> <li>• Wide operating voltage range.</li> </ul>

No.	Name	Description
42	Smoke Detector	<p>The smoke detector uses the scattered light principle to detect smoke entering the detector's inner chamber.</p> <ul style="list-style-type: none"> <li>• Good response to slow-burning, smoldering fires.</li> <li>• Unaffected by wind or atmospheric pressure.</li> <li>• Some models are equipped with a flashing LED and magnetic test switch.</li> <li>• Alarm indicator: Red light-emitting diode (LED) emits red light.</li> </ul>
43	Aerosol Fire Extinguishing Device	<p>Monitors fire signals inside the cabinet and implements fire suppression. When a fire occurs, the aerosol fire extinguishing device, upon receiving an electrical activation signal or open flame, ignites a thermal fuse. The electric igniter thermal fuse burns and activates the aerosol generator in the extinguishing device. The heat released through a series of reactions decomposes the chemical coolant, enabling the combined action of the aerosol generator and coolant to extinguish the fire.</p>
44	Document Shelf	-
45	Fire Alarm Action Signal Port	<p>Dry contact signal interface, normally NC (Normally Closed). Voltage: 0-24Vdc, current: 0.3A. Connect the audible and visual alarm cable.</p>
46	Maintenance Hook Shelf	<p>When disassembling the Pack and PCU, the maintenance hook can be taken from here for operation.</p>

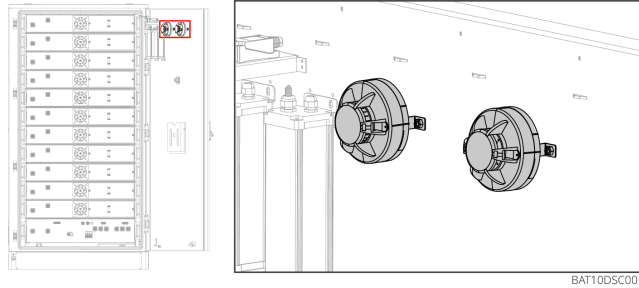
No.	Name	Description
47	Lifting Ring Installation Hole	-
48	Air Conditioner Switch	Connect the air conditioner power cable to control the air conditioner's power supply.

### Fire Protection System Description



1	2	3	4
Smoke detector	Heat detector	Aerosol fire extinguishing device	Explosion-proof valve

#### ■ Temperature Detector & Smoke Detector



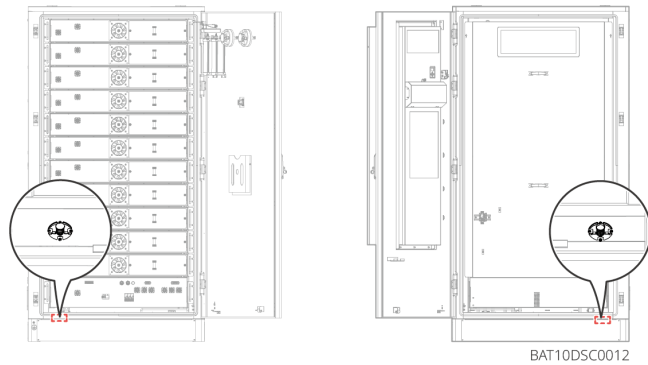
BAT10D5C0011

**Temperature Detection Principle:** The detector uses a negative temperature coefficient thermistor as the sensor, leveraging its sensitivity to ambient temperature to obtain environmental temperature information. The internal circuit converts this information into a voltage signal and transmits it to the microcontroller. The microcontroller analyzes and processes the signal through built-in intelligent algorithms while determining whether a fire or fault condition is present.

**Smoke Detection Principle:** The detector utilizes infrared scattering to detect fires. In a smoke-free state, it receives only very weak infrared light. When smoke enters the optical smoke detection chamber, the scattering effect strengthens the received light signal. When smoke reaches a certain concentration, an alarm signal is output.

Technical Specifications	Temperature Detector	Smoke Detector
Dimensions (mm)	102 × 55	
Installation Requirements	Screw-fixed	
indicator (Red)	Flashes during monitoring, stays lit during alarm	
Operating Temperature (°C)	-40~+85	
Relative Humidity	≤95%RH (non-condensing)	

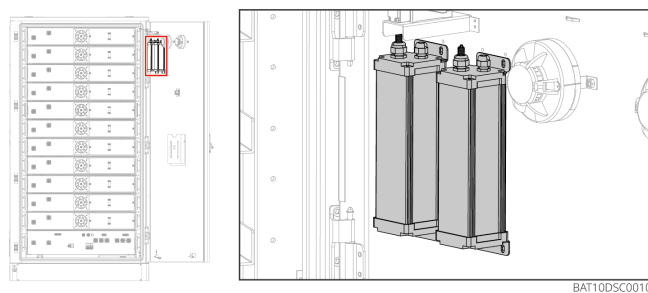
- **Explosion-Proof Valve**



When the internal pressure of a sealed product like a battery cabinet rises rapidly, the explosion-proof check valve's exhaust port opens to quickly and directionally release the internal gas, thereby preventing explosions in sealed products such as battery cabinets.

Technical Specifications	Explosion Relief Valve
Ingress Protection Rating	IP68
Opening Area	570 mm <sup>2</sup>
Operating Temperature	-40°C ~ +130°C
Flame Retardant Performance	UL94-V0

▪ **Aerosol Fire Extinguishing Device**



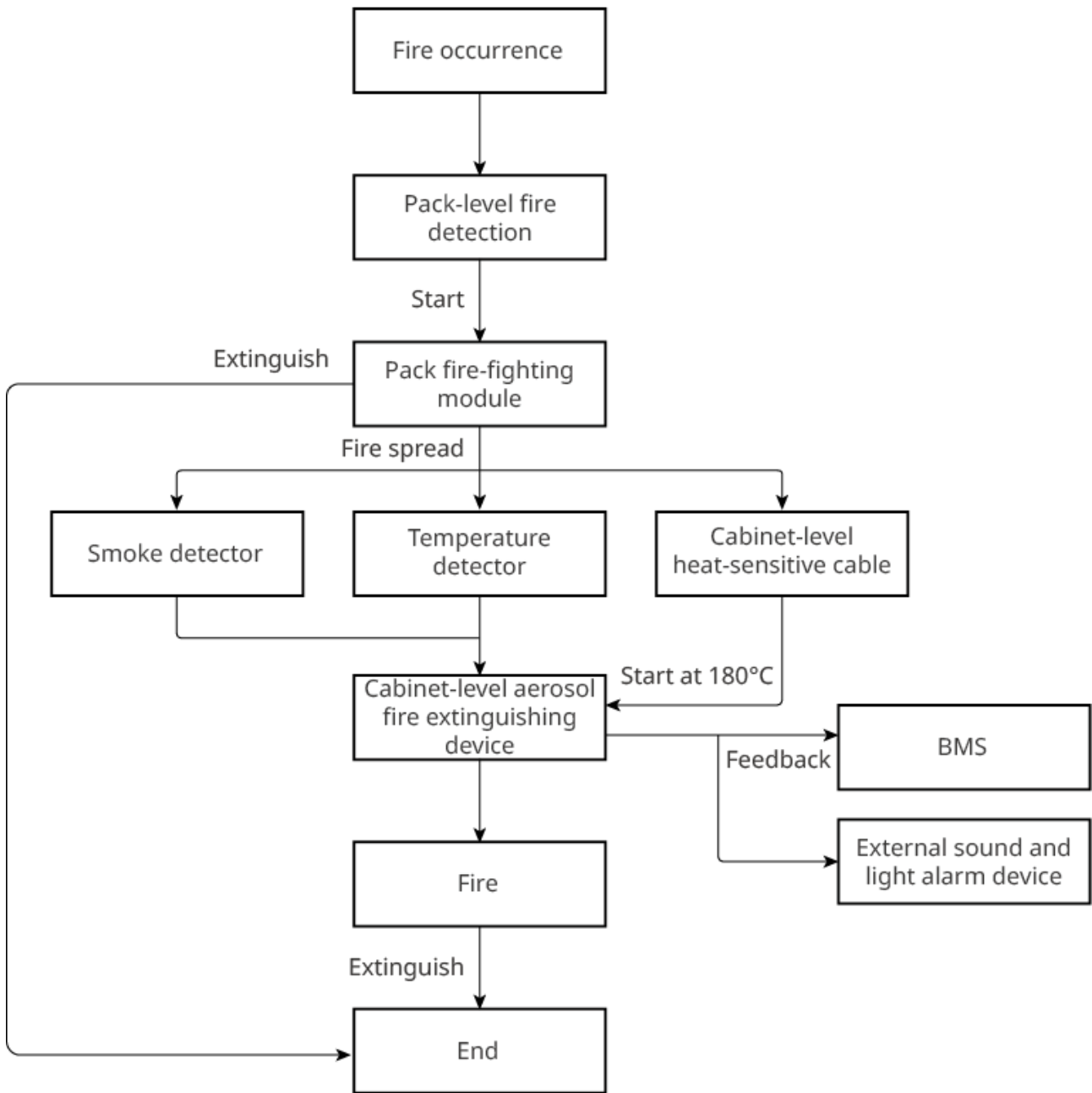
When a fire occurs, upon receiving an electrical activation signal or when an open flame ignites the thermal fuse, the electric initiator or burning thermal fuse activates the aerosol generating agent within the fire extinguishing device. The heat released by the redox reaction of the aerosol generating agent causes the chemical coolant to decompose, enabling both the aerosol generating agent and the coolant to

participate in fire suppression.

<b>Technical Specifications</b>	<b>Aerosol Fire Extinguishing Device</b>
Operating Environment Temperature Range	-30°C ~ +70°C
Operating Environment Relative Humidity	≤95%RH
Thermal Activation Temperature	185±10°C

### **Fire Protection Logic**

The fire protection for this battery system employs a graded response design. When a fire occurs inside a battery Pack, it is first detected by the Pack-level detector, which immediately activates the Pack's internal aerosol fire extinguishing device for initial suppression. If the fire is not controlled and spreads further, it will trigger cabinet-level fire protection. When both the smoke and temperature detectors detect a fire or an open flame ignites the thermal fuse (temperature reaching 180°C), the cabinet-level aerosol fire extinguishing device is automatically activated for comprehensive fire suppression. The aerosol generating agent produces fire suppressants through a combustion reaction, and the heat released during the reaction decomposes the chemical coolant. The aerosol suppressant and coolant work synergistically to extinguish the fire. Simultaneously, the BMS receives the feedback signal from the fire protection system, triggering external audible and visual alarms until the fire is completely extinguished.

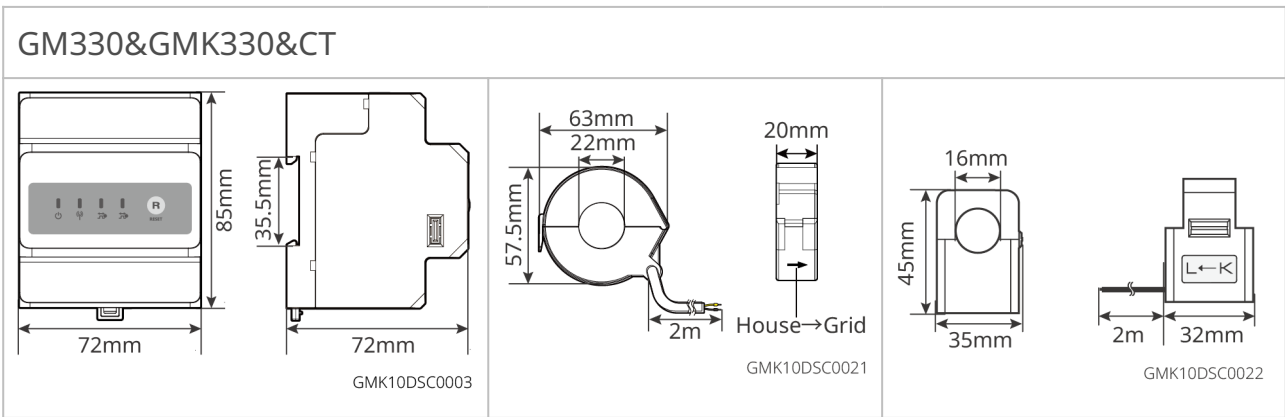
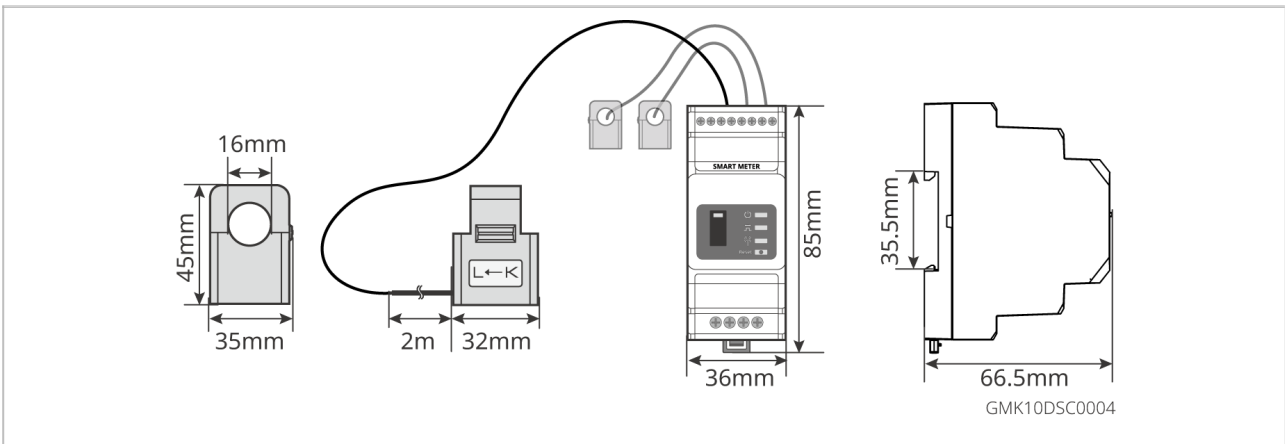


ET5010MTN0001

### 2.2.3 Smart Meter

Smart Meter can measure parameters such as grid voltage, current, power, frequency, electric energy, etc., and transmit the information to the inverter to control the input and output power of the energy storage system.

GM3000&CT

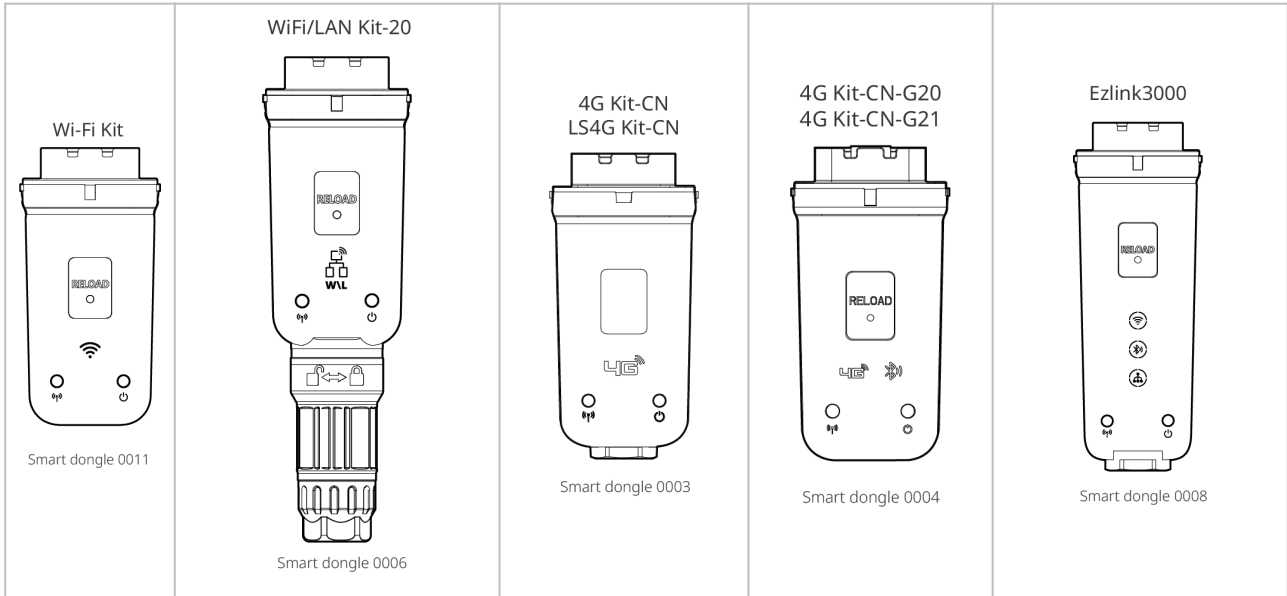


No.	model	Applicable Scenarios
1	GM3000	CT replacement not supported, CT ratio: 120A: 40mA
2	GM330	CT can be purchased from GoodWe or separately, CT ratio requirement: nA: 5A <ul style="list-style-type: none"> <li>nA: CT primary side input current, where n ranges from 200-5000</li> <li>5A: CT secondary side output current</li> </ul>
3	GMK330	CT shipped with the meter, CT ratio: <ul style="list-style-type: none"> <li>120A: 40mA</li> <li>200A: 50mA (Brazil only)</li> </ul>

### 2.2.4 Smart Dongle

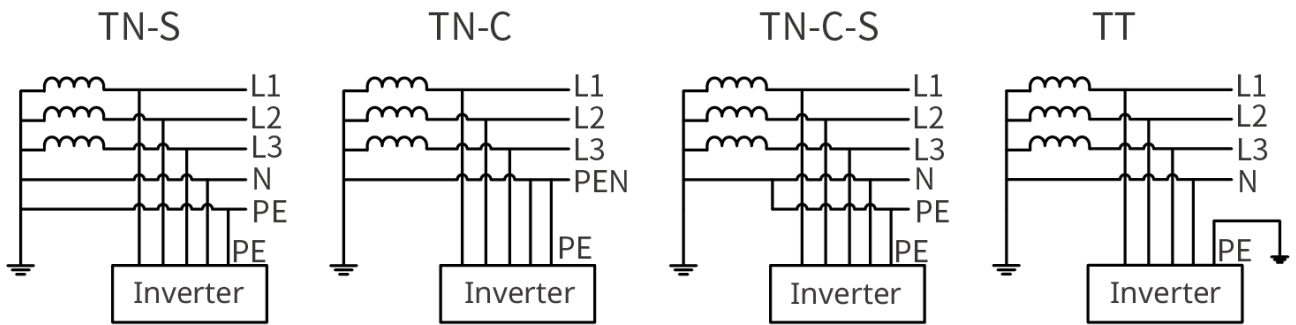
The Smart Dongle is primarily used for real-time transmission of various inverter

power generation data to the SEMS Portal remote monitoring platform, and for connecting to the Smart Dongle via the SolarGo APP for local device commissioning and debugging.



No.	model	Signal Type	Applicable Scenario
1	Wi-Fi Kit	WiFi	Single inverter scenario
2	WiFi/LAN Kit-20	WiFi, LAN, Bluetooth	
3	LS4G Kit-CN 4G Kit-CN	4G	
4	4G Kit-CN-G20 4G Kit-CN-G21	4G, Bluetooth 4G, Bluetooth, CNSS	
5	Ezlink3000	WiFi, LAN, Bluetooth	Master unit in multi-inverter scenario

## 2.3 Supported Grid Types

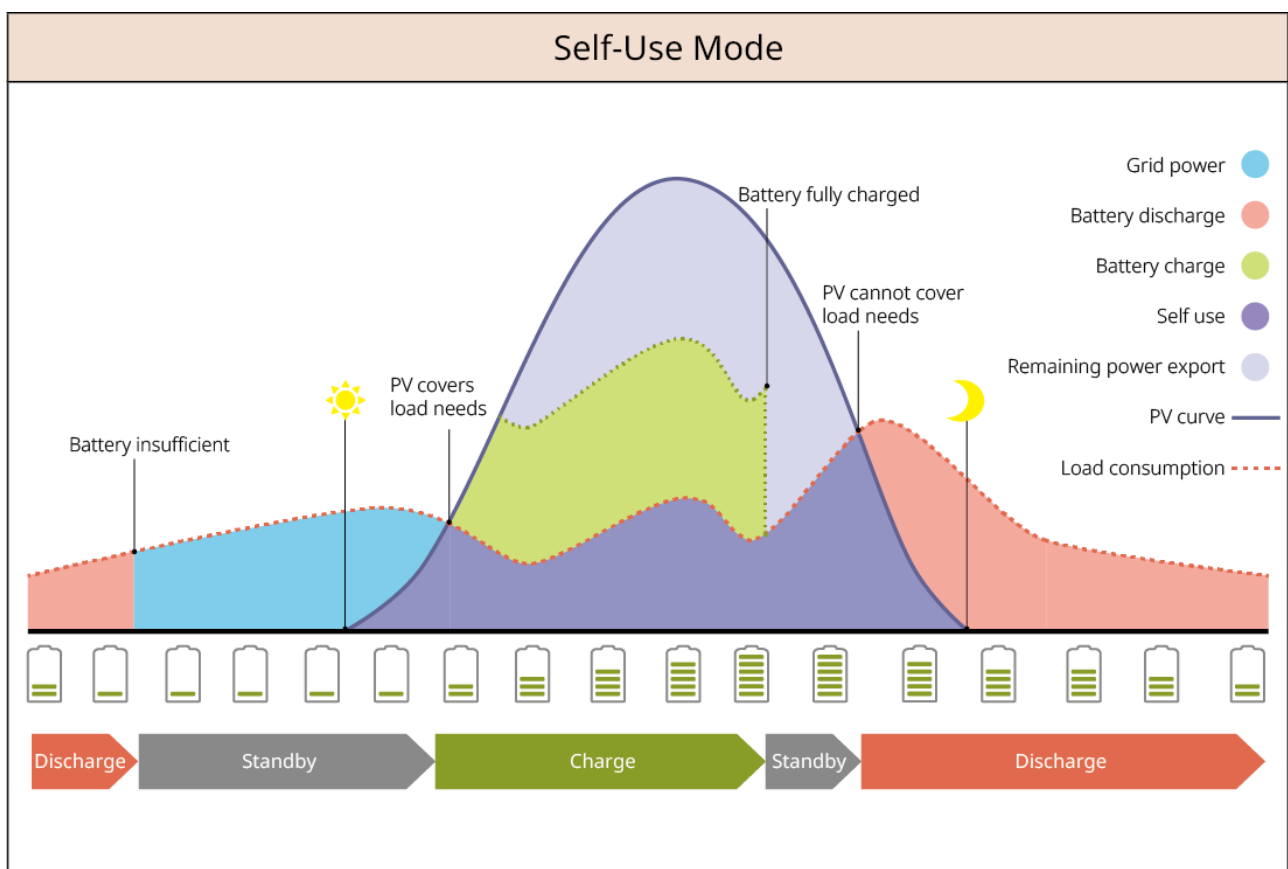


TNNET0003

## 2.4 System Working Mode

### Self-consumption Mode

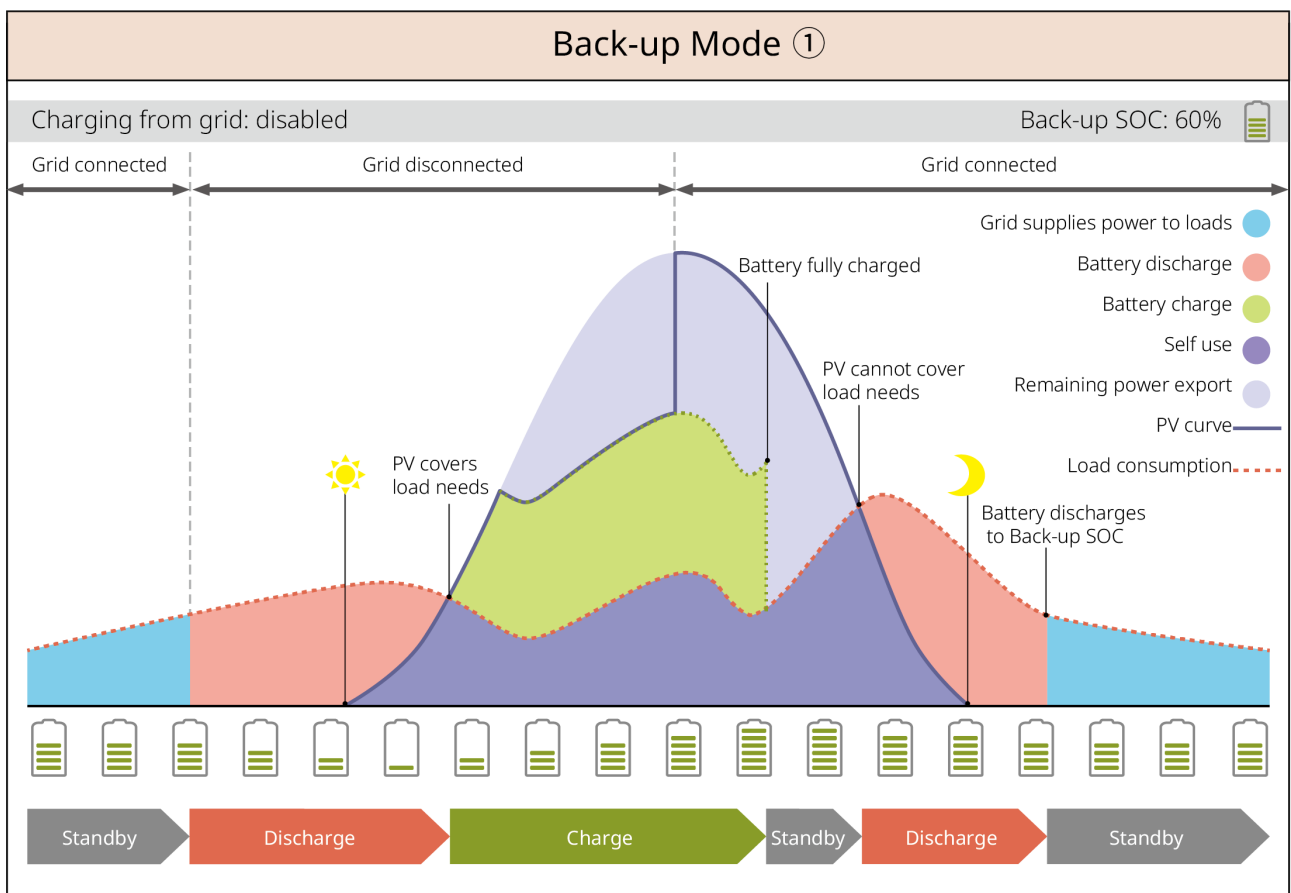
- The fundamental operating mode of the system.
- PV generation primarily supplies power to the loads. Excess power charges the battery, and any remaining surplus is sold to the grid. When PV generation is insufficient to meet load demand, the battery supplies power to the loads. If the battery power is also insufficient, the grid supplies power to the loads.

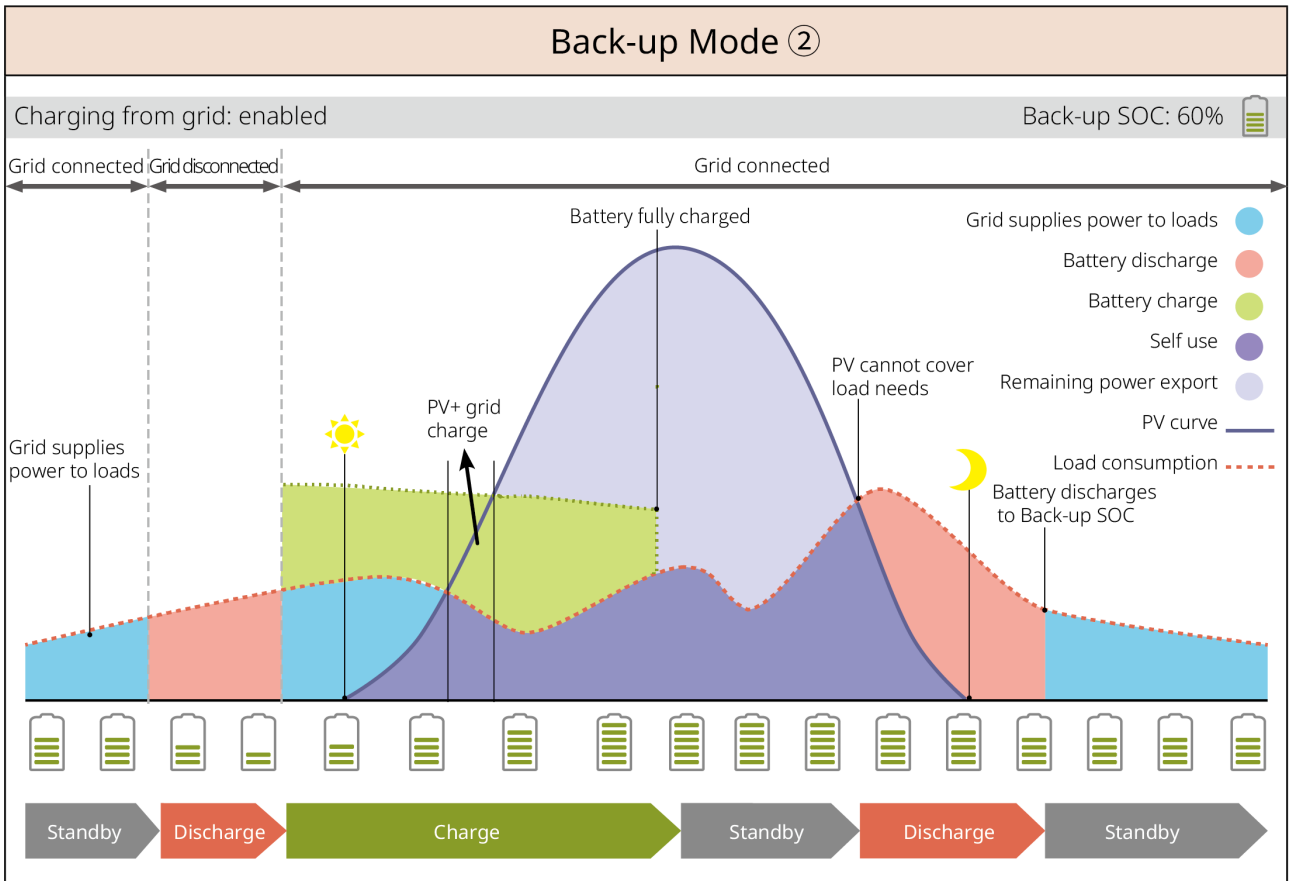


SLG00NET0009

## Backup Mode

- Recommended for use in areas with unstable grid power.
- When the grid fails, the inverter switches to off-grid operation mode, and the battery discharges to supply power to the loads, ensuring uninterrupted power for the BACK-UP Loads. When the grid is restored, the inverter switches back to grid-connected operation mode.
- To ensure the battery SOC is sufficient to maintain normal system operation during off-grid periods, the system will charge the battery using PV or grid power to the backup SOC during grid-connected operation. If charging the battery from the grid is required, please ensure compliance with local grid regulations and laws.





SLG00NET0003

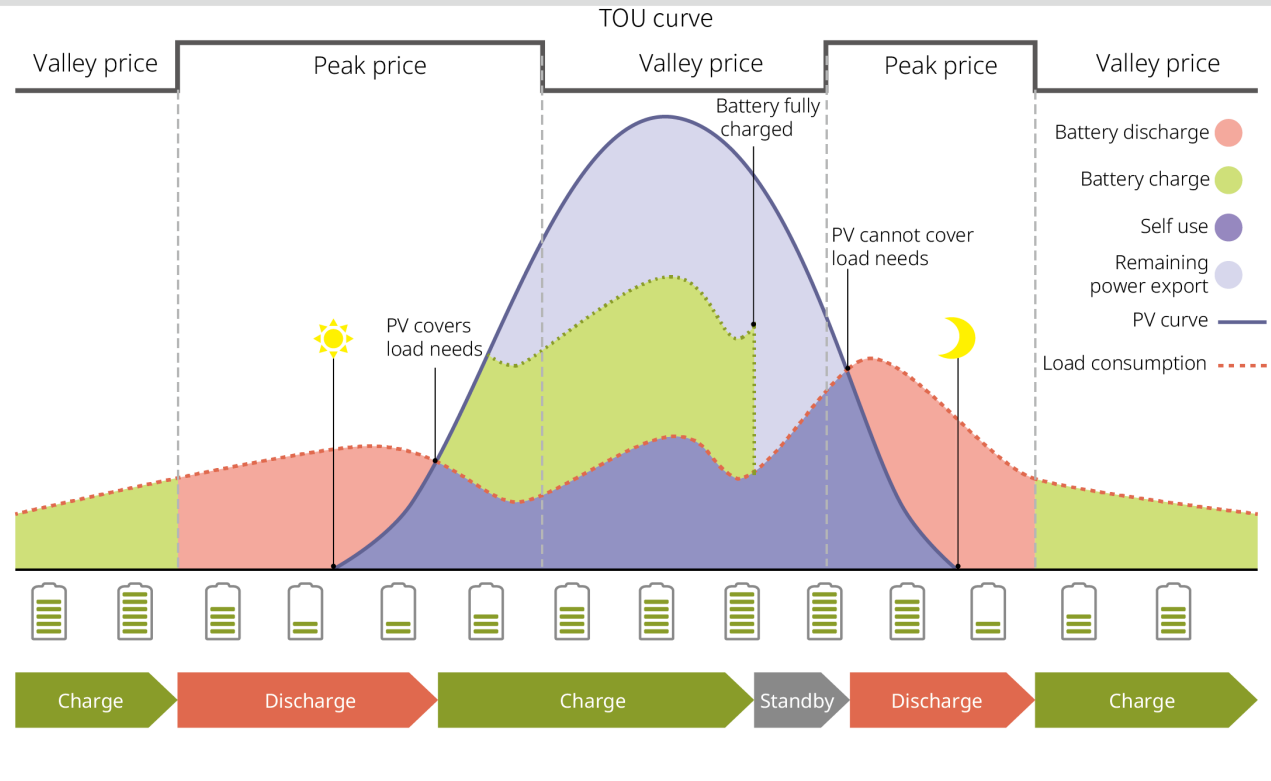
## TOU Mode

Subject to compliance with local laws and regulations, electricity buying and selling are scheduled for different time periods based on peak and off-peak grid electricity prices.

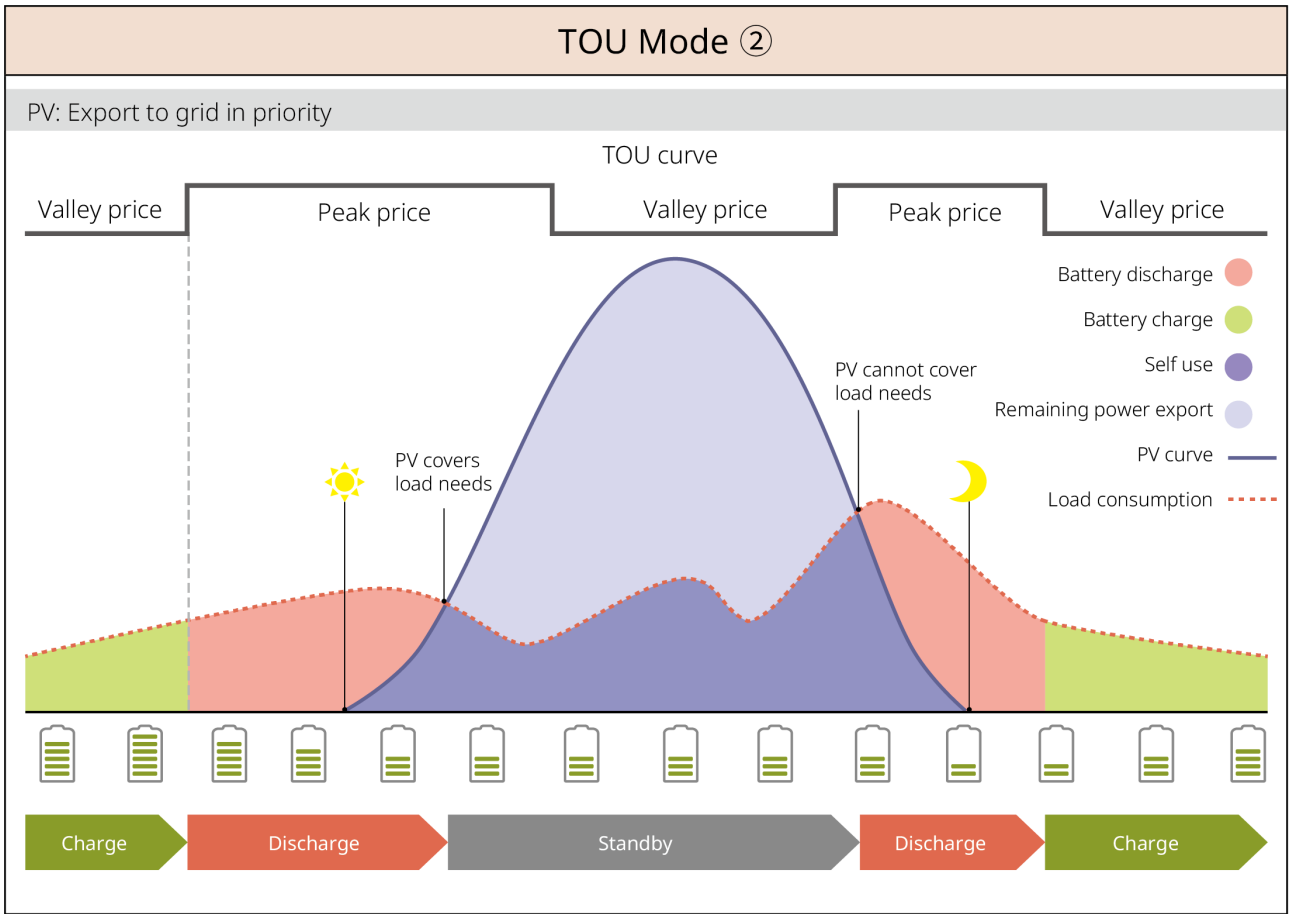
For example: During off-peak price periods, set the battery to charging mode to purchase electricity from the grid for charging. During peak price periods, set the battery to discharging mode to supply power to the loads via the battery.

# TOU Mode ①

PV: Charge battery in priority



SLG00NET0004



SLG00NET0005

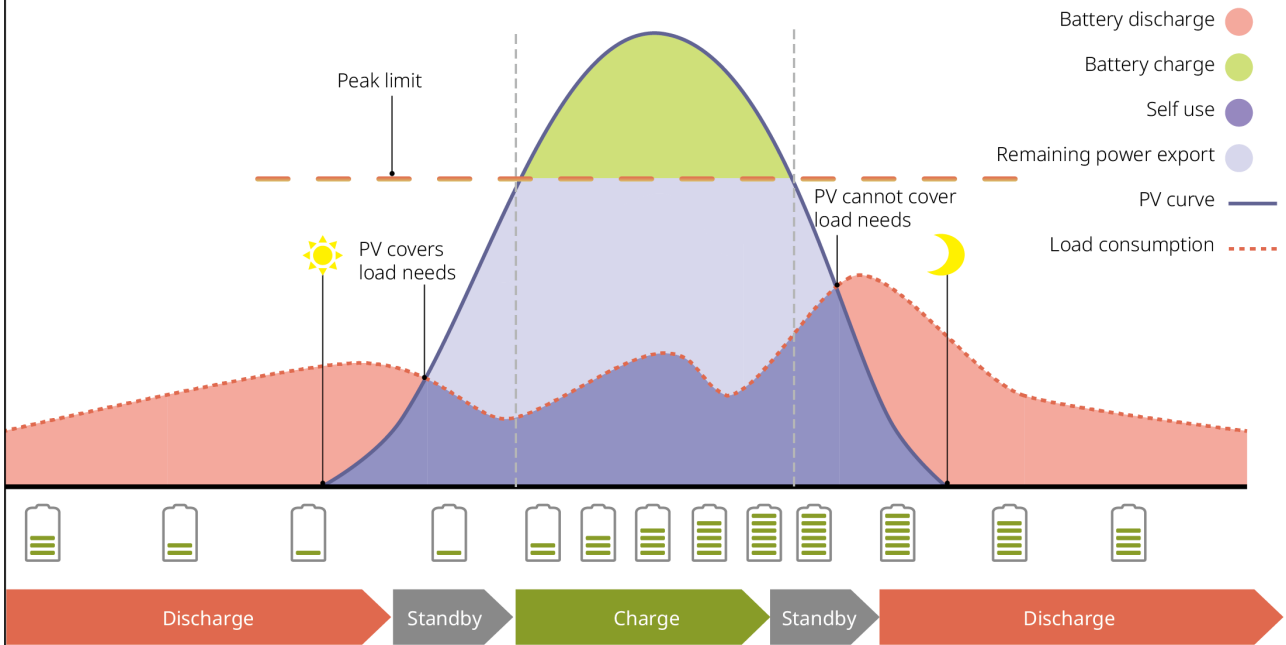
### Delayed Charging Mode

- Suitable for areas with grid feed-in power limitations.
- Setting a peak power limit allows excess PV generation beyond the grid limit to be used for charging the battery. Alternatively, setting a PV charging time period allows PV generation to be used for charging the battery during that period.

# Delayed Charging ①

PV > Peak Limit

Switch to Charge: enabled/disabled

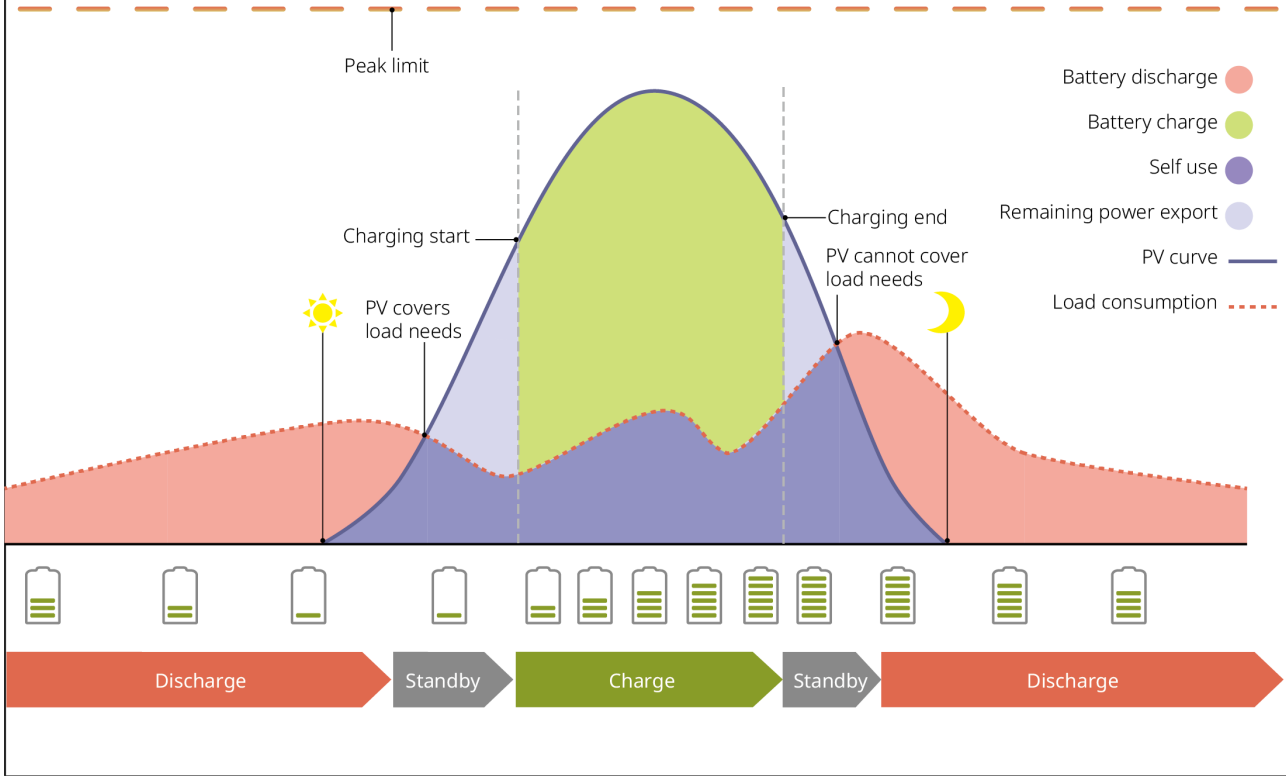


SLG00NET0006

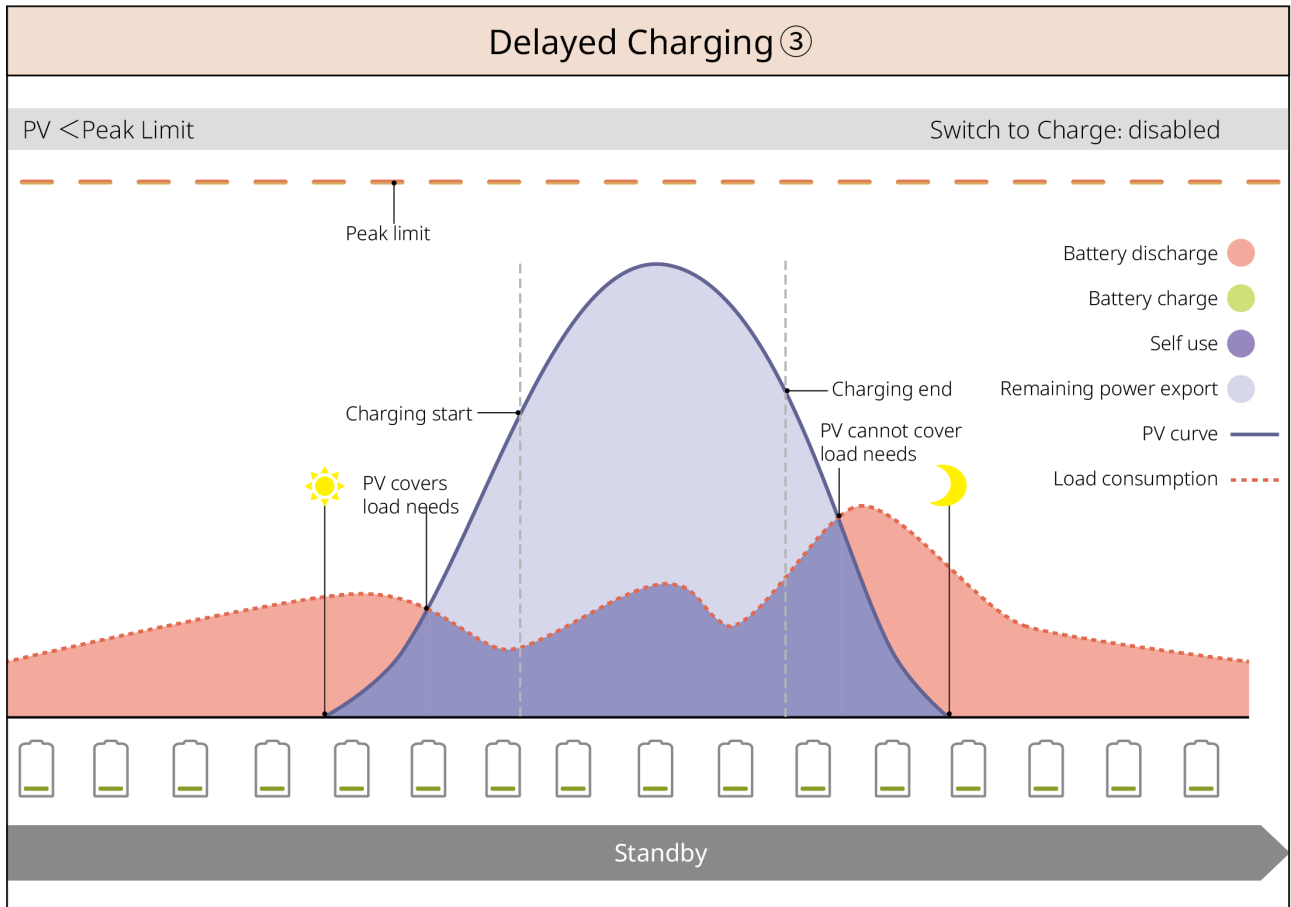
## Delayed Charging ②

PV < Peak Limit

Switch to Charge: enabled



SLG00NET0007



SLG00NET0008

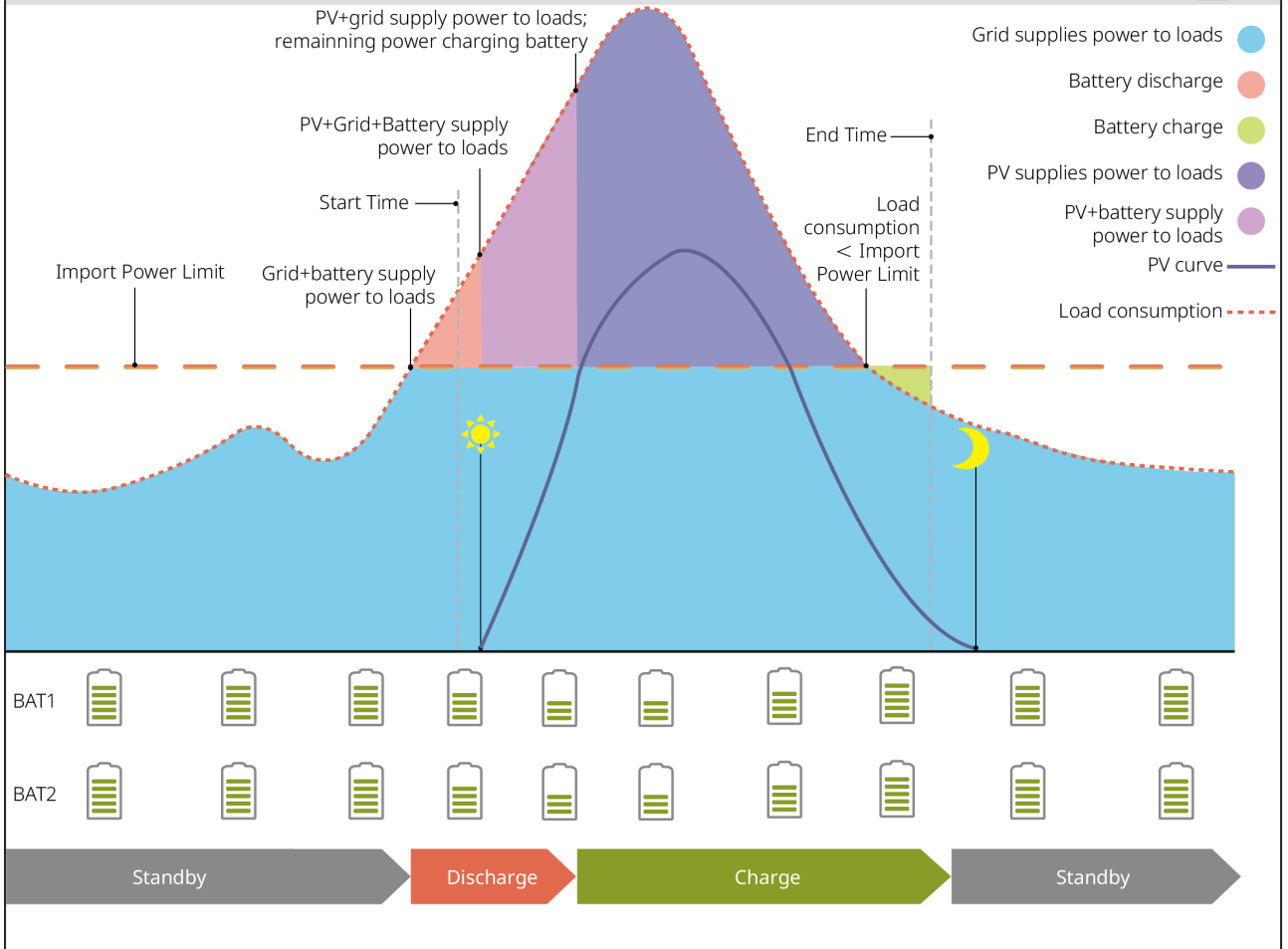
### Peakshaving Mode

- Primarily applicable to commercial and industrial scenarios.
- When the total load power consumption exceeds the electricity quota within a short period, battery discharge can be utilized to reduce the portion of consumption exceeding the quota.
- When the SOC of both inverter battery strings is below the reserved SOC for peak shaving, the system purchases electricity from the grid based on the time period, load consumption, and the peak purchase power limit. When the SOC of only one inverter battery string is below the reserved SOC for peak shaving, the system purchases electricity from the grid based on the load consumption and the peak purchase power limit.

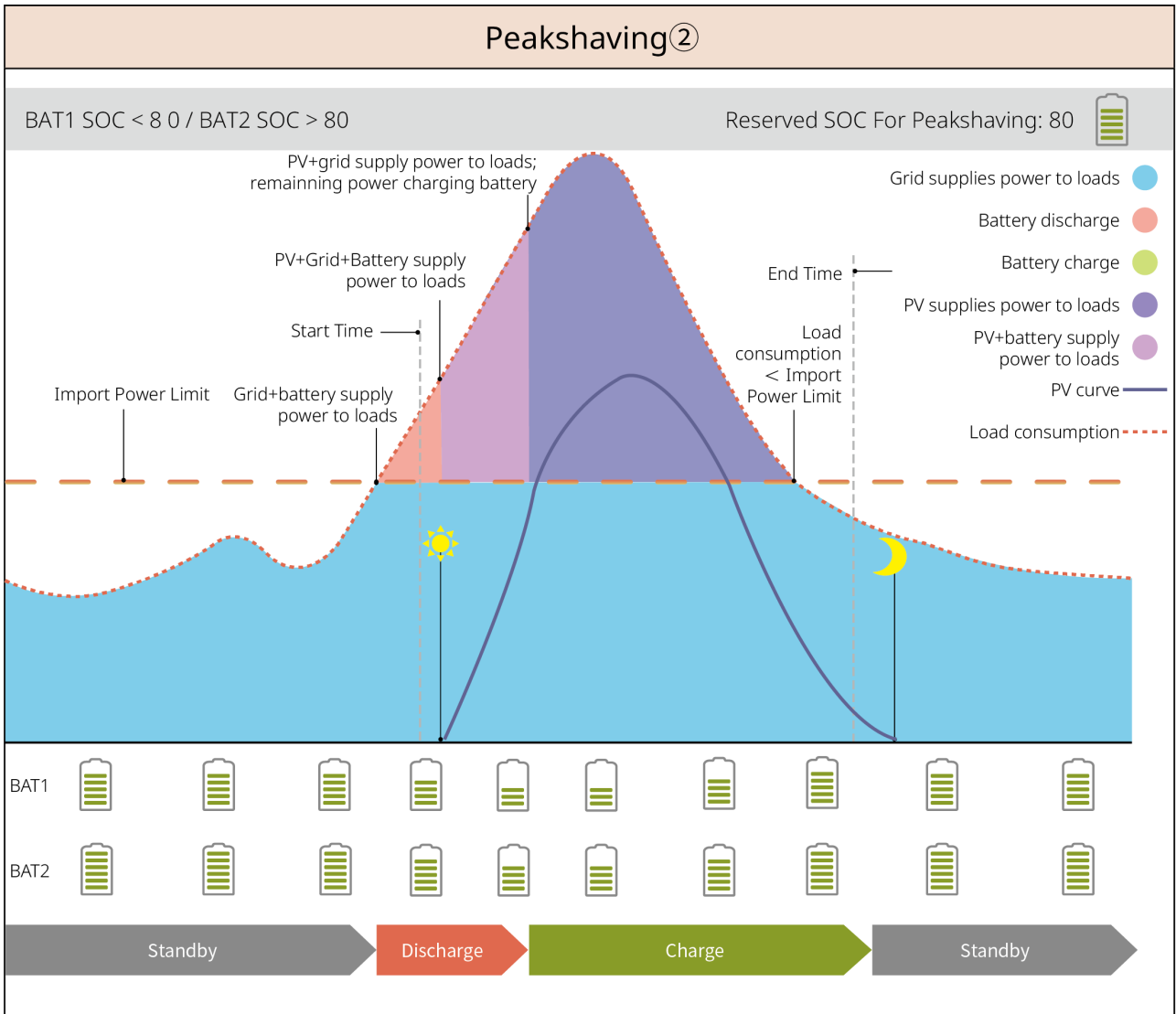
# Peakshaving ①

BAT1/BAT2 SOC < 80

Reserved SOC For Peakshaving: 80 



SLG00NET0010



SLG00NET0011

## Off-grid Mode

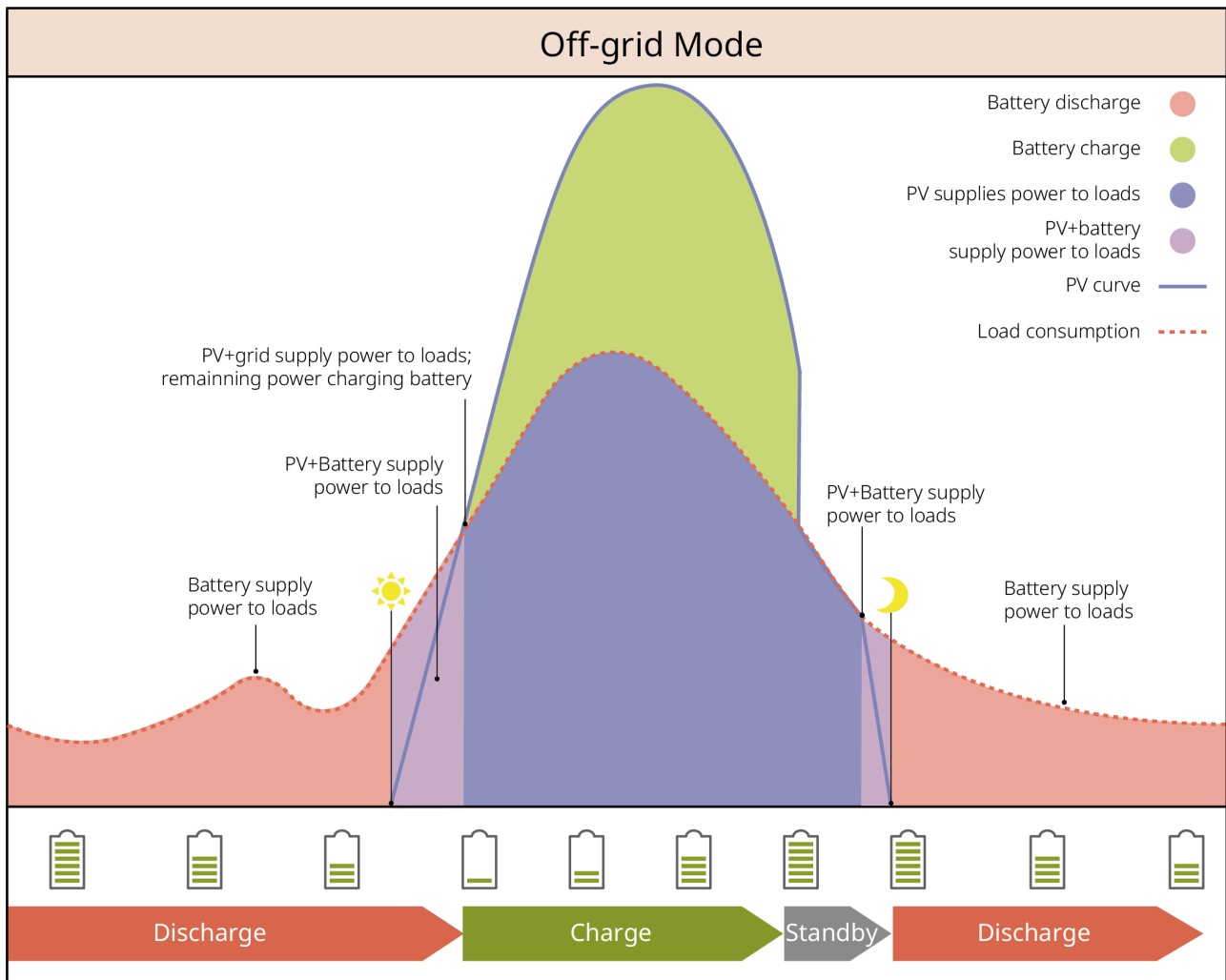
### NOTICE

When the inverter is not connected to the battery system, do not operate in pure off-grid mode.

When the grid fails, the inverter switches to off-grid operation mode.

- During the day, PV generation primarily supplies power to the loads, with excess power charging the battery.
- At night, the battery discharges to supply power to the loads, ensuring uninterrupted power for the BACK-UP Loads.
- Off-grid SOC Recovery: After the system operates off-grid, the battery gradually

recovers to the minimum SOC through PV generation or other power generation methods.



SLG00NET0012

## 2.5 Features

### NOTICE

Specific features are subject to the actual product configuration.

#### AFCI

The inverter integrates an AFCI circuit protection device, which detects arc faults and rapidly cuts off the circuit upon detection, thereby preventing electrical fires.

Causes of arc faults:

- Damage to the connector connections within the photovoltaic system.
- Incorrect or damaged cable connections.
- Aging of connectors or cables.

#### Arc Detection Method

- The inverter integrates the AFCI function, complying with the IEC 63027 standard.
- When the inverter detects an arc fault, the time and fault phenomenon can be displayed via the App.
- After the inverter triggers an AFCI alarm, it will shut down for protection. The inverter will automatically reconnect to the grid and resume operation after the alarm is cleared.
  - Auto Reconnect: If the inverter triggers an AFCI alarm < 5 times within 24 hours, the alarm can be automatically cleared after five minutes, and the inverter will reconnect to the grid and resume operation.

Manual Reconnect: If the inverter triggers the 5th AFCI alarm within 24 hours, the alarm must be cleared manually before the inverter can reconnect to the grid and resume operation.

model	Label	Description
GW12KL-ET	F-I-AFPE-1-2/2-2	F: Full coverage I: Integrated AFPE: Detection and interruption capability provided 1: 1 monitored string per input port 2/2: 2/2 input ports per channel 2: 2 monitored channels
GW15K-ET		
GW20K-ET		
GW18KL-ET	F-I-AFPE-1-2/4-2	F: Full coverage I: Integrated AFPE: Detection and interruption capability provided 1: 1 monitored string per input port 2/4: 2/4 input ports per channel 2: 2 monitored channels
GW20K-ET		
GW29.9K-ET		
GW30K-ET		

#### Three-Phase Unbalanced Output

The inverter's grid-tie side and BACK-UP side both support three-phase unbalanced output, allowing loads of different power ratings to be connected to each phase. The maximum output power per phase for different models is shown in the table below:

No.	model	Maximum Output Power per Phase
1	GW12KL-ET	4kW
2	GW18KL-ET	6kW
3	GW15K-ET	5kW
4	GW20K-ET	6.7kW
5	GW25K-ET	8.3kW
6	GW29.9K-ET	10kW
7	GW30K-ET	10kW

### load control

The inverter's dry contact control port supports connecting additional contactors to control the switching on or off of loads. It supports household loads, heat pumps, etc.

Load control methods are as follows:

- Time Control: Set the time for switching the load on or off. The load will automatically turn on or off within the set time period.
- Switch Control: When the control mode is set to ON, the load will turn on; when set to OFF, the load will turn off.
- BACK-UP Loads Control: The inverter has a built-in relay dry contact control port, which can control whether a load is switched off via the relay. In off-grid mode, if an overload on the BACK-UP side is detected and the battery SOC value falls below the set off-grid protection value, the load connected to the relay port can be switched off.

### Rapid Shutdown (RSD)

In a Rapid Shutdown system, the RSD transmitter and receiver work together to achieve rapid system shutdown. The receiver maintains module output by receiving signals from the transmitter. The transmitter can be external or built into the inverter. In an emergency, by activating an external trigger device, the transmitter can be stopped, thereby shutting down the modules.

- External Transmitter
  - Transmitter Models: GTP-F2L-20, GTP-F2M-20  
<https://en.goodwe.com/Ftp/Installation-instructions/RSD2.0-transmitter.pdf>
  - Receiver Models: GR-B1F-20, GR-B2F-20  
[https://en.goodwe.com/Ftp/EN/Downloads/User%20Manual/GW\\_RSD-20\\_Quick-Installation-Guide-POLY.pdf](https://en.goodwe.com/Ftp/EN/Downloads/User%20Manual/GW_RSD-20_Quick-Installation-Guide-POLY.pdf)
- Built-in Transmitter
  - External Trigger Device: External switch
  - Receiver Models: GR-B1F-20, GR-B2F-20  
[https://en.goodwe.com/Ftp/EN/Downloads/User%20Manual/GW\\_RSD-20\\_Quick-Installation-Guide-POLY.pdf](https://en.goodwe.com/Ftp/EN/Downloads/User%20Manual/GW_RSD-20_Quick-Installation-Guide-POLY.pdf)

# 3 Check and Storage

## 3.1 Check Before Receiving

Before signing for the product, please carefully check the following:

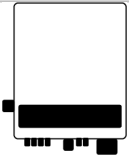
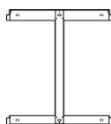
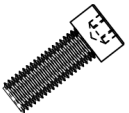
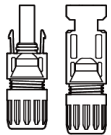
1. Check the outer packaging for any damage, such as deformation, holes, cracks, or any other signs that could indicate damage to the equipment inside the box. If damaged, do not open the packaging and contact your dealer.
2. Check if the device model is correct. If it does not match, do not open the packaging and contact your dealer.


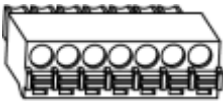
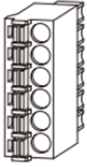
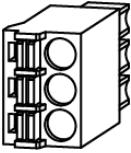



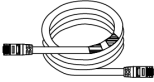
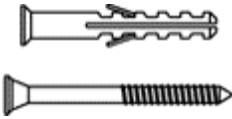
## 3.2 deliverables

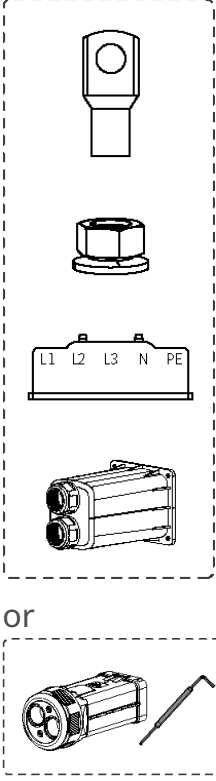
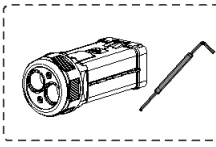
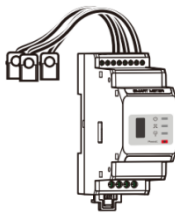
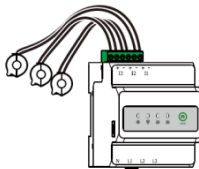
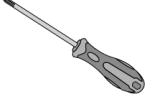
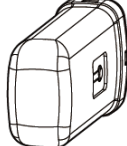
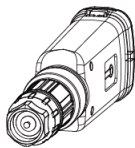

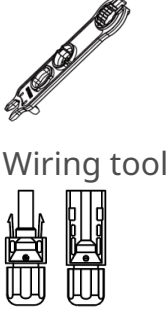
 **WARNING**



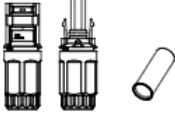
Check if the type and quantity of the delivered items are correct, and if there is any damage to the appearance. If damaged, please contact your dealer.  
After removing the delivered items from the packaging, do not place them on rough, uneven, or sharp surfaces to avoid paint chipping.

### 3.2.1 Inverter Deliverables

Part	Description	Part	Description
	Inverter x 1		Backplate x 1
	Back-mounting fastening screws x 2		PV connector GW12KL-ET, GW15K-ET, GW20K-ET: 4 GW18KL-ET, GW25K-ET, GW29.9K-ET, GW30K-ET: 6

Part	Description	Part	Description
	PV wiring tool x 1		7PIN communication terminal x 1
	6PIN communication terminal x 1		3PIN communication terminal x 1
	Protective PE screw x 1		PIN terminal x N The number of PIN terminals provided with the unit varies depending on the inverter configuration. Please refer to the actual shipment.
	Grounding terminal x 1		BMS/Meter Communication cable GW12KL-ET, GW15K- ET, GW20K-ET: 2 GW18KL-ET, GW25K- ET, GW29.9K-ET, GW30K-ET: 3
			expansion bolt x 6

Part	Description	Part	Description
 <p>or</p> 	<p>Subject to actual shipment</p> <ul style="list-style-type: none"> <li>• OT terminal x 12</li> <li>• AC terminal flange nut x 20</li> <li>• Insulation board for AC terminal x 1</li> <li>• AC terminal protective cover x 1</li> <li>• Hexagon screwdriver x 1</li> </ul>	 <p>or</p> 	<p>Smart meter and accessories x 1 Subject to actual shipment</p>
	<p>screwdriver x 1</p>	 <p>or</p> 	<p>Smart Dongle x 1</p>
	<p>Product documentation x 1</p>		
 <p>Wiring tool</p> <p>Battery connector</p>	<p>(Optional)</p> <p>Wiring tool x 1</p> <p>Battery connector: GW12KL-ET, GW15K-ET, GW20K-ET: 1 GW18KL-ET, GW25K-ET, GW29.9K-ET, GW30K-ET: 2</p>		

Part	Description	Part	Description
 Wiring tool  Hexagon screwdriver  Battery connector	(Optional) Wiring tool x 2 Hexagon screwdriver x 1 Battery connector: GW12KL-ET, GW15K-ET, GW20K-ET: 1 GW18KL-ET, GW25K-ET, GW29.9K-ET, GW30K-ET: 2		


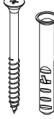






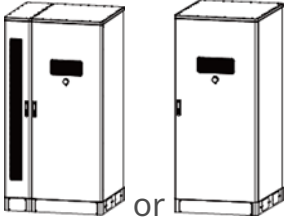









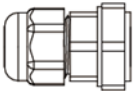

Part	Description	Part	Description
	cable tie x 10		expansion bolt x 4
	M5 hex screw x 10		M5 nut x 5
	Protective cover right side panel x 1		Protective cover left side panel x 1
	Protective cover base plate x 1		Protective cover front panel x 1

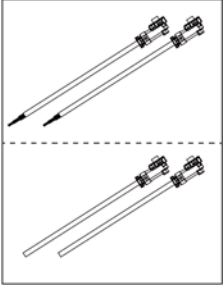
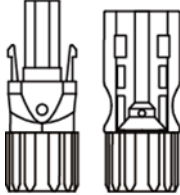
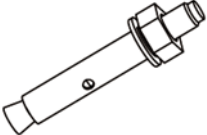
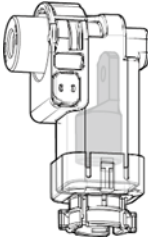


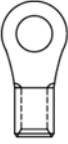
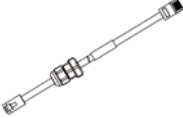
Table40 Protective Cover Accessories (Australia only)


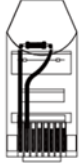

### 3.2.2 Batteries Deliverables

#### 3.2.2.1 Lynx C Series 60kWh Industrial and Commercial Battery System

Component	Quantity	Component	Quantity
	<p>Battery system x 1            GW60KWH-D-10:            Includes AC cabinet            GW60KWH-D-10 (No            expansion cabinet):            Does not include AC            cabinet</p>		<ul style="list-style-type: none"> <li>• Battery-Battery connection aluminum busbar            When all busbars are shipped with accessories, the quantity in accessories is 10</li> <li>• When some busbars are shipped with accessories, the quantity in accessories is 3 (other busbars are pre-installed on the battery)</li> </ul>
	<p>Battery-High voltage box connection aluminum busbar</p> <ul style="list-style-type: none"> <li>• When the busbar is shipped with accessories, the quantity in accessories is 1</li> <li>• When the busbar is pre-installed on the battery for shipment, the quantity of this accessory is 0</li> </ul>		<p>Battery-High voltage box fixing screw x 2</p>

Component	Quantity	Component	Quantity
	<p>Battery-Battery fixing screw</p> <ul style="list-style-type: none"> <li>• When all busbars are shipped with accessories, the quantity of screws in accessories is 22</li> <li>• When some busbars are shipped with accessories, the quantity of screws in accessories is 6</li> </ul>		<p>Lifting ring x 4</p>
	<p>Inverter Back-up wiring terminal x 5</p>		<p>M12 waterproof component x 2</p>
	<p>M18 waterproof component x 2</p>		<p>M20 waterproof component x 2</p>
	<p>M22 waterproof component x 4</p>		<p>cable tie x 10</p>

Component	Quantity	Component	Quantity
	Inverter-High voltage box power cable GW60KWH-D-10 (No expansion cabinet): 0 GW60KWH-D-10: 1		Inverter battery wiring terminal GW60KWH-D-10 (No expansion cabinet): 0 GW60KWH-D-10: N N: Please refer to the actual product shipment
	Expansion screw x 4		High voltage box power wiring terminal GW60KWH-D-10 (No expansion cabinet): 2 GW60KWH-D-10: 1
	Air conditioning water pipe x 1		M5 nut x 9
	Grounding terminal x 1		Inverter-High voltage box communication cable GW60KWH-D-10: 1 GW60KWH-D-10 (No expansion cabinet): 0

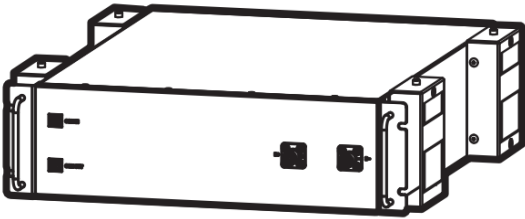
Component	Quantity	Component	Quantity
	Product documentation x 1		Terminating resistor x 2 GW60KWH-D-10 (No expansion cabinet): 1 GW60KWH-D-10: 0
	Wrench x 0: Fire department has a "Do Not Touch" label Wrench x 1: Other	-	-

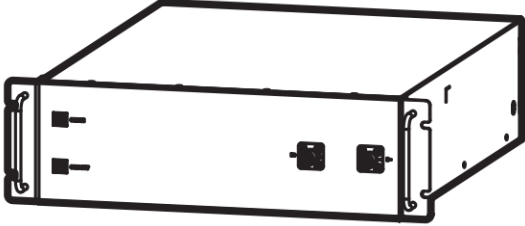
### 3.2.2.2 BAT-S Series 15.3-56.3kWh High Voltage Battery

#### NOTICE

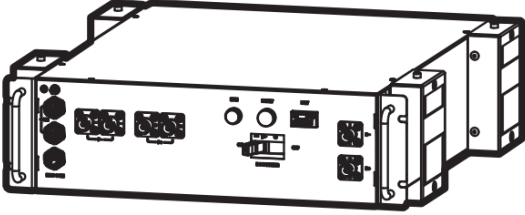
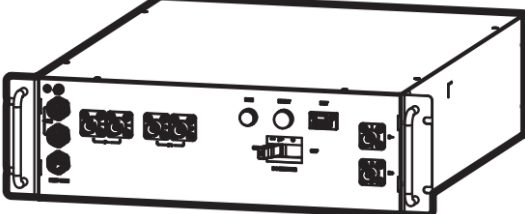
Different regions support different configurations and installation plans. For details, please consult sales.

#### Battery PACK

Component	Description
Stack Mounting 	

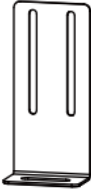


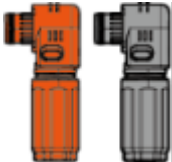

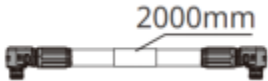

Component	Description
<p data-bbox="320 495 549 533">Rack Mounting</p> 	<p data-bbox="730 353 932 392">Battery PACK</p> <ul data-bbox="730 434 1139 882" style="list-style-type: none"> <li>• GW15.3-BAT-I-G10: × 3</li> <li>• GW20.4-BAT-I-G10: × 4</li> <li>• GW25.6-BAT-I-G10: × 5</li> <li>• GW30.7-BAT-I-G10: × 6</li> <li>• GW35.8-BAT-I-G10: × 7</li> <li>• GW40.9-BAT-I-G10: × 8</li> <li>• GW46.0-BAT-I-G10: × 9</li> <li>• GW51.2-BAT-I-G10: × 10</li> <li>• GW56.3-BAT-I-G10: × 11</li> </ul>





## PCU

Part	Description
<p data-bbox="304 1167 564 1205">Stack Installation</p> 	<p data-bbox="730 1442 847 1480">PCU × 1</p>
<p data-bbox="309 1473 560 1512">Rack Installation</p> 	

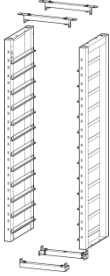

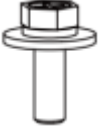
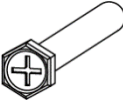
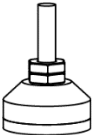
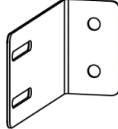
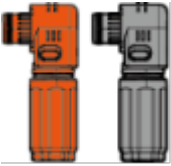
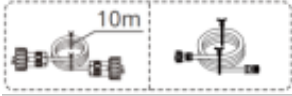
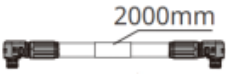

## Accessories

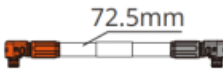
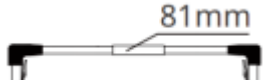






- Stack Mounting

Part	Description	Part	Description
	Ground lock bracket×4		Wall lock bracket×4
	Equipotential bonding sheet×15		M5 screw×N
	Cable gland×1		Expansion bolt×8
	Adjustable foot×4		Base×1
	Power connector×2		Battery to inverter communication cable×1
 2000mm	B- power cable×1	 70mm	B+ power cable×1
 72.5mm	Internal battery power cable ×N	 81mm	Internal battery communication cable ×N
	Grounding terminal ×2		M12 expansion bolt ×4





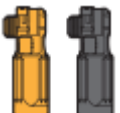
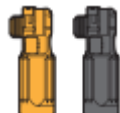
Part	Description	Part	Description
	Nameplate×1		Cable tie×10
	adapter bonnet×4 (Included only for machines shipped after April 3, 2026)		Product documentation×1

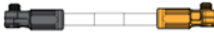
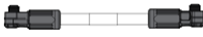
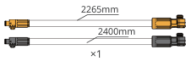

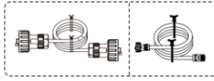



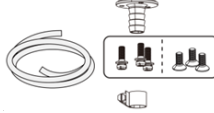




• Rack Mounting

Part	Description	Part	Description
	Battery rack ×1		Rubber pad×4
	M5 screw ×N		ST6.3 screw ×4
	Adjustable feet ×4		Wall mounting bracket ×2
	Power connector ×2		Battery to inverter communication cable ×1
	B- power cable ×1		B+ power cable ×1

Part	Description	Part	Description
	Internal battery power cable ×N		Internal battery communication cable ×N
	Grounding terminal ×2		M12 expansion bolt ×4
	Nameplate ×1		Cable tie ×10
	adapter bonnet ×1		Product documentation ×1

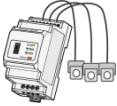
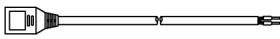
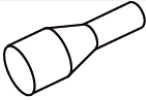

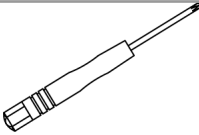
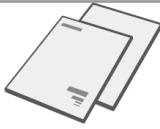
### 3.2.2.3 BAT Series 61.4-112.6kWh Commercial & Industrial Battery System

Part	Description	Part	Description
	battery cabinet×1		Expansion screw×4
	Grounding M5 screw×3		Grounding terminal×3
	Inverter battery connection terminal 25mm <sup>2</sup> ×2		Battery inter-connection terminal 50mm <sup>2</sup> ×2

Part	Description	Part	Description
	Pack series connection harness×N <ul style="list-style-type: none"> <li>GW61.4-BAT-AC-G10: ×5</li> <li>GW92.1-BAT-AC-G10: ×8</li> <li>GW102.4-BAT-AC-G10: ×9</li> <li>GW112.6-BAT-AC-G10: ×10</li> </ul>		Pack negative to HV box negative harness×1
	Inverter battery connection (positive)×1 Inverter battery connection (negative)×1		Adapter bracket×2 (For ET100 use only)
	Battery to inverter communication network cable×1		Air conditioner power supply harness kit×1
	Lifting eye×4		Cable tie×20
	Air conditioner water pipe kit×1		fireproofing mud×8
	Corrugated pipe connector×6		25mm <sup>2</sup> to 10mm <sup>2</sup> round tube terminal×4
	Product documentation×1	-	-

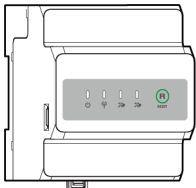

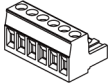
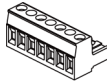
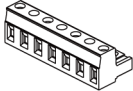



### 3.2.3 Smart Meter Deliverables (GM3000)



Part	Quantity	Part	Quantity
------	----------	------	----------

	Smart meter and CT x 1		2PIN terminal to RJ45 terminal adapter cable x 1
	PIN terminal x 3		USB plug x 1
	screwdriver x 1		Product documentation x 1

### 3.2.4 Smart Meter Deliverables GM330&GMK330

#### 3.2.4.1 Attachment List

Component	Description	Component	Description
	Smart Meter x1 GMK330: CT×3; GMK360: CT×6; GM330: CT x 0.		2PIN Communication Terminal x1 For GM330.
	6PIN Communication Terminal x1 For GM330.		7PIN Communication Terminal x1 For GM330.
	Meter Communication Terminal For GMK330/GMK360.		RS485 Communication Terminal x 1
	2PIN Terminal to RJ45 Terminal Adapter Cable x 1		screwdriver x1

Component	Description	Component	Description
	PIN terminal GMK330/GMK360: x 5 ; GM330: x 6.		Product Documentation x 1

### 3.3 Storage

#### NOTICE

[1] The storage time is calculated from the SN date on the battery's outer packaging. After exceeding the storage period, charge-discharge maintenance is required. (Battery maintenance time = SN date + charge-discharge maintenance cycle). For how to view the SN date, refer to: [10.4.SN Code Meaning\(Page 300\)](#).

[2] After the charge-discharge maintenance is qualified, if there is a Maintaining Label on the outer box, please update the maintenance information on the Maintaining Label. If there is no Maintaining Label, please record the maintenance time and battery SOC yourself and keep the data properly to facilitate the preservation of maintenance records.

If the device is not put into use immediately, please store it according to the following requirements. After long-term storage, the device must be inspected and confirmed by professionals before it can continue to be used.

1. If the inverter's storage time exceeds two years or the non-operational time after installation exceeds 6 months, it is recommended to undergo inspection and testing by professionals before being put into use.
2. To ensure the good electrical performance of the internal electronic components of the inverter, it is recommended to power it on once every 6 months during storage. If it has not been powered on for over 6 months, it is recommended to undergo inspection and testing by professionals before being put into use.
3. To protect battery performance and service life, it is advised to avoid long-term idle storage. Prolonged storage may cause deep discharge of the battery, leading to irreversible chemical loss, resulting in capacity decay or even complete failure. It is recommended to use it promptly. If the battery requires long-term storage, please maintain it according to the following requirements:

Battery	Initial SOC Range for Battery Storage	Recommended Storage Temperature	Charge/Discharge Maintenance Cycle[1]	Battery Maintenance Method[2]
Lynx C Series 60kWh Commercial & Industrial Battery System	30%~40%	0~35°C	-20~0°C, ≤1 month 0~+35°C, ≤6 months 35~+45°C, ≤1 month	Please consult the distributor or after-sales service center for maintenance methods.
BAT-S Series 15.3-56.3kWh High Voltage Battery	30%~40%	0~35°C	-20~35°C (≤12 months) 35~+45°C (≤6 months)	
BAT-C Series 61.4-112.6kWh Commercial & Industrial Battery System				

### Packaging Requirements:

Ensure that the outer packaging box is not removed and the desiccant inside the box is not lost.

### Environmental Requirements:

1. Ensure that the device is stored in a cool place, avoiding direct sunlight.
2. Ensure the storage environment is clean, with appropriate temperature and humidity ranges, and no condensation. If there is condensation on the device ports, do not install the device.
3. Ensure that the device is stored away from flammable, explosive, corrosive, and other hazardous materials.

### Stacking Requirements:

1. Ensure that the inverter stacking height and direction are arranged according to the instructions on the packaging box label.
2. Ensure that there is no risk of tipping after the inverters are stacked.

# 4 Installation



Please use the delivery components shipped with the device for installation and electrical connection. Damage caused otherwise is not covered under warranty.

## 4.1 System Installation and Commissioning Procedure

Steps	1 Installation		2 PE		3 Battery		4 COM		
Battery	Lynx C 60kWh C&I	BAT 61.4-112.6kWh C&I	Lynx C 60kWh C&I	BAT 61.4-112.6kWh C&I	Lynx C 60kWh C&I	BAT 61.4-112.6kWh C&I	Lynx C 60kWh C&I	BAT 61.4-112.6kWh C&I	
Tools	1 D: 80mm ø: 14mm 2 M12 50N-m		M5 4.5N-m	M5 4N-m	1 M6 6N-m 2 M8 10N-m 3 M5 4.5-6N-m Recommend: YQK-70	Crimping tool			
Battery	BAT 15.3-56.3kWh HV 1 2 3 4 5 6 7 8 9 10 11 12 13 14 15 16 17 18 19 20 21 22 23 24 25 26 27 28 29 30 31 32 33 34 35 36 37 38 39 40 41 42 43 44 45 46 47 48 49 50 51 52 53 54 55 56 57 58 59 60 61 62 63 64 65 66 67 68 69 70 71 72 73 74 75 76 77 78 79 80 81 82 83 84 85 86 87 88 89 90 91 92 93 94 95 96 97 98 99 100				1 2 M5 4N-m	3 4 5 6 D: 80mm ø: 14mm M12 50N-m	7 M5 4N-m	8 9 M5 4N-m Crimping tool	10 11 12 13 14 15 16 17 18 19 20 21 22 23 24 25 26 27 28 29 30 31 32 33 34 35 36 37 38 39 40 41 42 43 44 45 46 47 48 49 50 51 52 53 54 55 56 57 58 59 60 61 62 63 64 65 66 67 68 69 70 71 72 73 74 75 76 77 78 79 80 81 82 83 84 85 86 87 88 89 90 91 92 93 94 95 96 97 98 99 100
Tools	1 2 3 4 5 6 7 8 9 10 11 12 13 14 15 16 17 18 19 20 21 22 23 24 25 26 27 28 29 30 31 32 33 34 35 36 37 38 39 40 41 42 43 44 45 46 47 48 49 50 51 52 53 54 55 56 57 58 59 60 61 62 63 64 65 66 67 68 69 70 71 72 73 74 75 76 77 78 79 80 81 82 83 84 85 86 87 88 89 90 91 92 93 94 95 96 97 98 99 100				1 2 M5 4N-m	3 4 5 6 D: 80mm ø: 14mm M12 50N-m	7 M5 4N-m	8 9 M5 4N-m Crimping tool	10 11 12 13 14 15 16 17 18 19 20 21 22 23 24 25 26 27 28 29 30 31 32 33 34 35 36 37 38 39 40 41 42 43 44 45 46 47 48 49 50 51 52 53 54 55 56 57 58 59 60 61 62 63 64 65 66 67 68 69 70 71 72 73 74 75 76 77 78 79 80 81 82 83 84 85 86 87 88 89 90 91 92 93 94 95 96 97 98 99 100

ET3010NT0015

Steps	1 Installation		2 PE		3 Battery				4 COM	
Battery	Lynx C 60kWh C&I BAT 61.4-112.6kWh C&I		Lynx C 60kWh C&I BAT 61.4-112.6kWh C&I		Lynx C 60kWh C&I BAT 61.4-112.6kWh C&I				Lynx C 60kWh C&I BAT 61.4-112.6kWh C&I	
Tools	1 D: 80mm φ: 14mm 2 M12 50N·m		M5 4.5N·m M5 4N·m		1 M6 6N·m 2 M8 10N·m Recommend: YQK-70 3 M5 4.5-6N·m				Crimping tool 1	
Steps	1 Installation	2 PE	3 PV	4 Battery	5 AC	6 COM	7 Communication module			
Inverter							Wi-Fi Kit	WiFi/LAN Kit-20	Ezlink3000	
Tools	1 M5 4.5N·m 2 M5 1.2-2N·m	M5 1.2-2N·m	Recommend: PV-CZM-61100	Recommend: VXC9	1 M5 2-3N·m 2 M6 3-4N·m	M4 1.5N·m	4G Kit-CN LS4G Kit-CN 4G Kit-CN-G20 4G Kit-CN-G21			
Steps	1 Installation		2 Cable Connections		3 Power	4 Commissioning				
Smart meter	GM3000	GM330/GMK330	GM3000		GMK330	GM330	AC breaker			
	GM330: CT×0 GMK330: CT×3		1.2-2N·m		1.2-2N·m		SEMS Portal APP or SEMS Portal WEB			

ETS0108N/TO05

## 4.2 Installation Requirements

### 4.2.1 Installation Environment Requirements

#### NOTICE

If installed in an environment below 0°C, the battery will be unable to recharge and restore energy after being fully discharged, resulting in battery undervoltage protection.

GW60KWH-D-10: Charging temperature range: 0<T<55°C; Discharging temperature range: -25<T<55°C

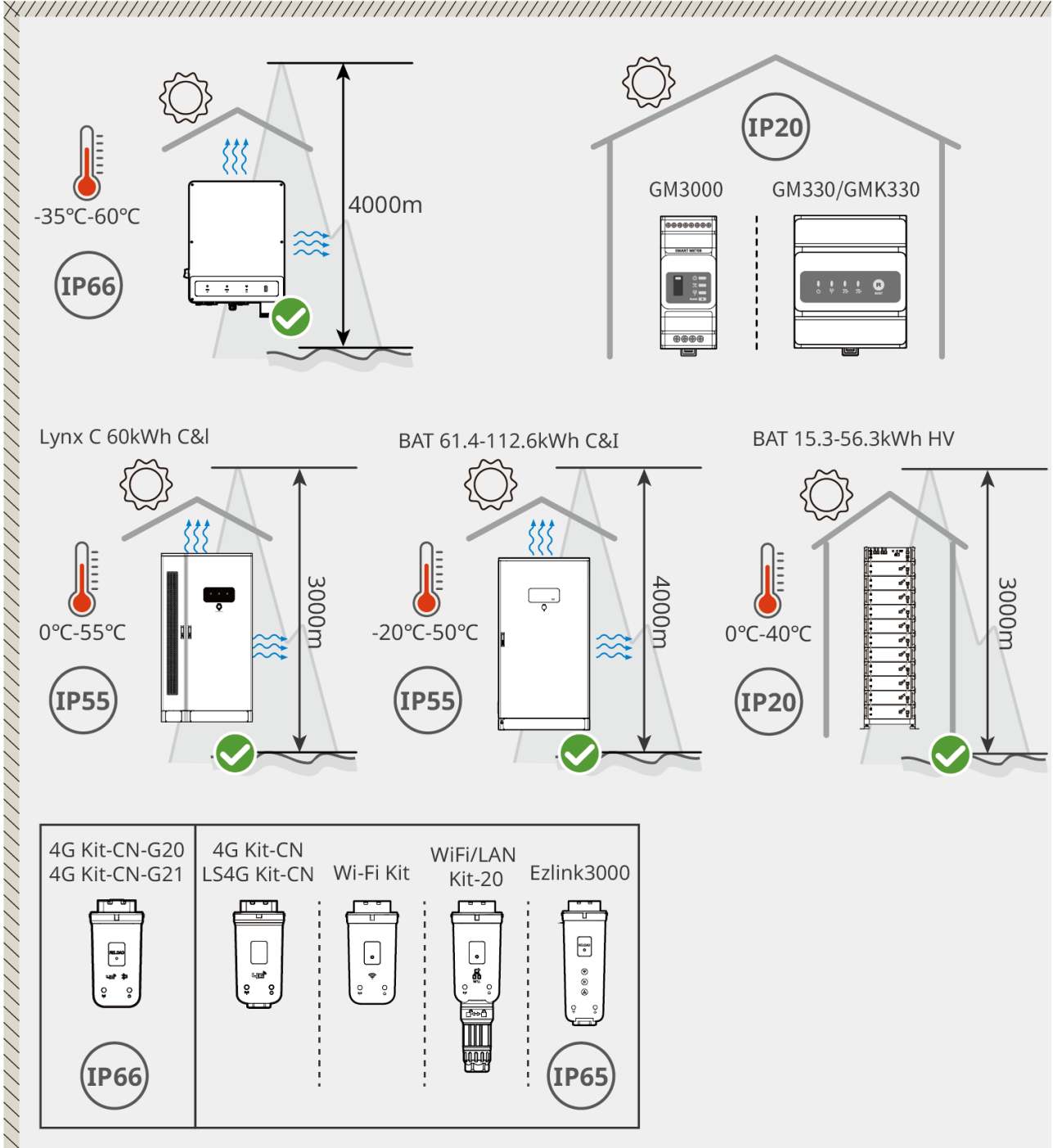
1. The equipment must not be installed in flammable, explosive, corrosive, or similar environments.
2. The temperature and humidity of the installation environment must be within a suitable range.
3. The installation location must be out of reach of children and avoid positions that are easily accessible.
4. The enclosure temperature may exceed 60°C during Inverter operation. Do not touch the enclosure before it cools down to avoid burns.

5. The Inverter should be installed away from direct sunlight, rain, snow accumulation, etc. It is recommended to install it in a sheltered location; a sunshade can be constructed if necessary.
6. Adverse environmental conditions such as direct sunlight and high temperatures may cause the Inverter's output power to derate.
7. The installation space must meet the equipment's ventilation, heat dissipation, and operational space requirements.
8. The installation environment must satisfy the equipment's ingress protection rating.
  - Inverters and smart communication sticks are suitable for both indoor and outdoor installation;
  - Electric meters are suitable for indoor installation;
  - Lynx C Series 60kWh Commercial & Industrial Battery System and BAT-C Series 61.4-112.6kWh Commercial & Industrial Battery System are suitable for indoor and outdoor installation. The BAT-S Series 15.3-56.3kWh High Voltage Battery is suitable for indoor installation and must be kept ventilated.
9. When installing equipment indoors, ensure there are no obstacles within a 10-meter diameter of the installation location.
10. During construction and installation, ensure the bottom of the equipment is above the local historical highest water level.
11. The installation height of the equipment should facilitate operation and maintenance, ensuring the equipment indicator lights, all labels are easily visible, and the wiring terminals are easily accessible.
12. The installation altitude of the equipment must be below the maximum operating altitude.
13. The battery system must be installed on a flat, dry surface. It must not be placed in a recessed or sloped area and is strictly prohibited from being installed on ground prone to water accumulation or subsidence. Ensure the ground can bear the weight of the battery system.
14. Before installing equipment outdoors in salt damage areas, consult the equipment manufacturer. Salt damage areas mainly refer to regions within 500 meters of the coastline. The affected area is related to sea wind, precipitation, terrain, and other conditions.
15. Keep away from strong magnetic field environments to avoid electromagnetic interference. If there are radio stations or wireless communication devices below 30MHz near the installation location, install the equipment according to the following requirements:
  - Inverter: Add a ferrite core with multiple windings on the Inverter's DC input lines or AC output lines, or add a low-pass EMI filter; or ensure the distance

between the Inverter and the wireless electromagnetic interference device exceeds 30m.

- Other equipment: Ensure the distance between the equipment and the wireless electromagnetic interference device exceeds 30m.

16. The length of the DC cables and communication cables between the battery and the Inverter must be less than 3m. Please ensure the installation distance between the Inverter and the battery meets the cable length requirement.



ET3010INT0007

## 4.2.2 Foundation Installation Requirements

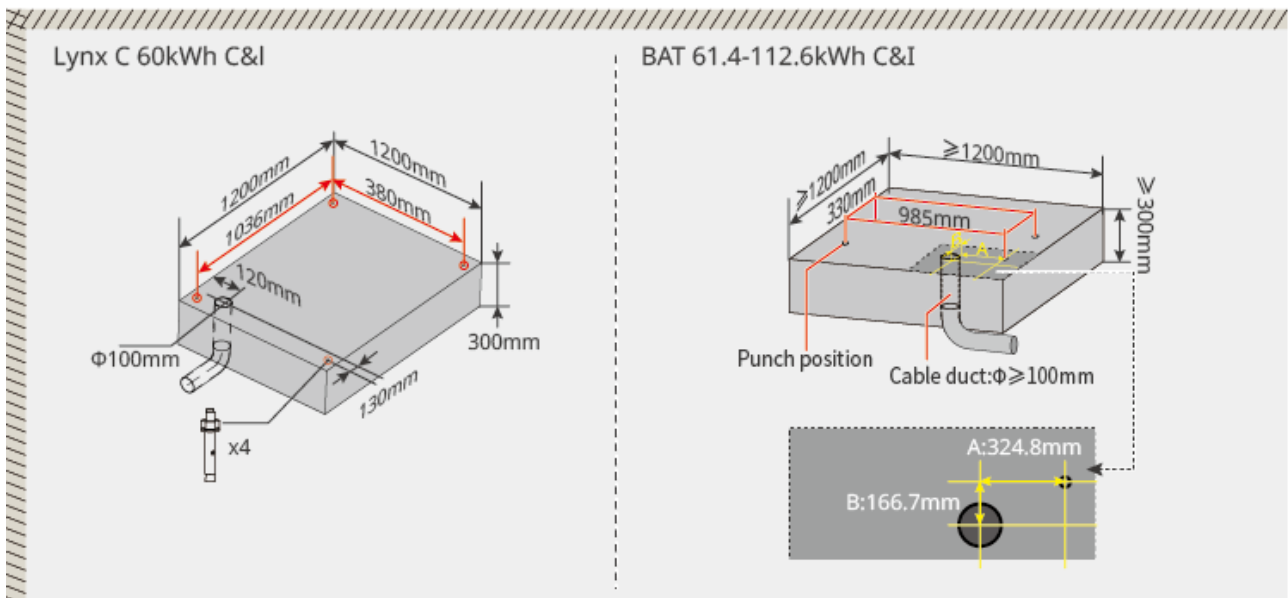
1. The foundation material must be C25 plain concrete hardened ground or other

non-combustible surfaces.

2. The foundation must have pre-reserved trenches or outlet holes to facilitate equipment cabling.
3. Equipment (including height, embedded expansion bolt parts, conduit, etc.) shall be adjusted based on the process and site conditions.
4. The top elevation of the equipment foundation can be adjusted according to the equipment and actual site requirements.
5. Ensure the equipment is installed horizontally; it must not be tilted or inverted.
6. Trench requirements:
  - If the equipment uses bottom cable entry, the trench must have a dust-proof and rodent-proof design to prevent foreign objects from entering.
  - The trench must have waterproof and moisture-proof design to prevent cable aging and short circuits, which could affect normal equipment operation.
  - Due to the relatively thick equipment cables, sufficient space for cables must be reserved during trench design to ensure smooth and non-abrasive cable connections.

## NOTICE

The conduit can be replaced on-site with 4 PVC pipes with a wire diameter of 125mm. Conduit does not need to be pre-installed for indoor environments.



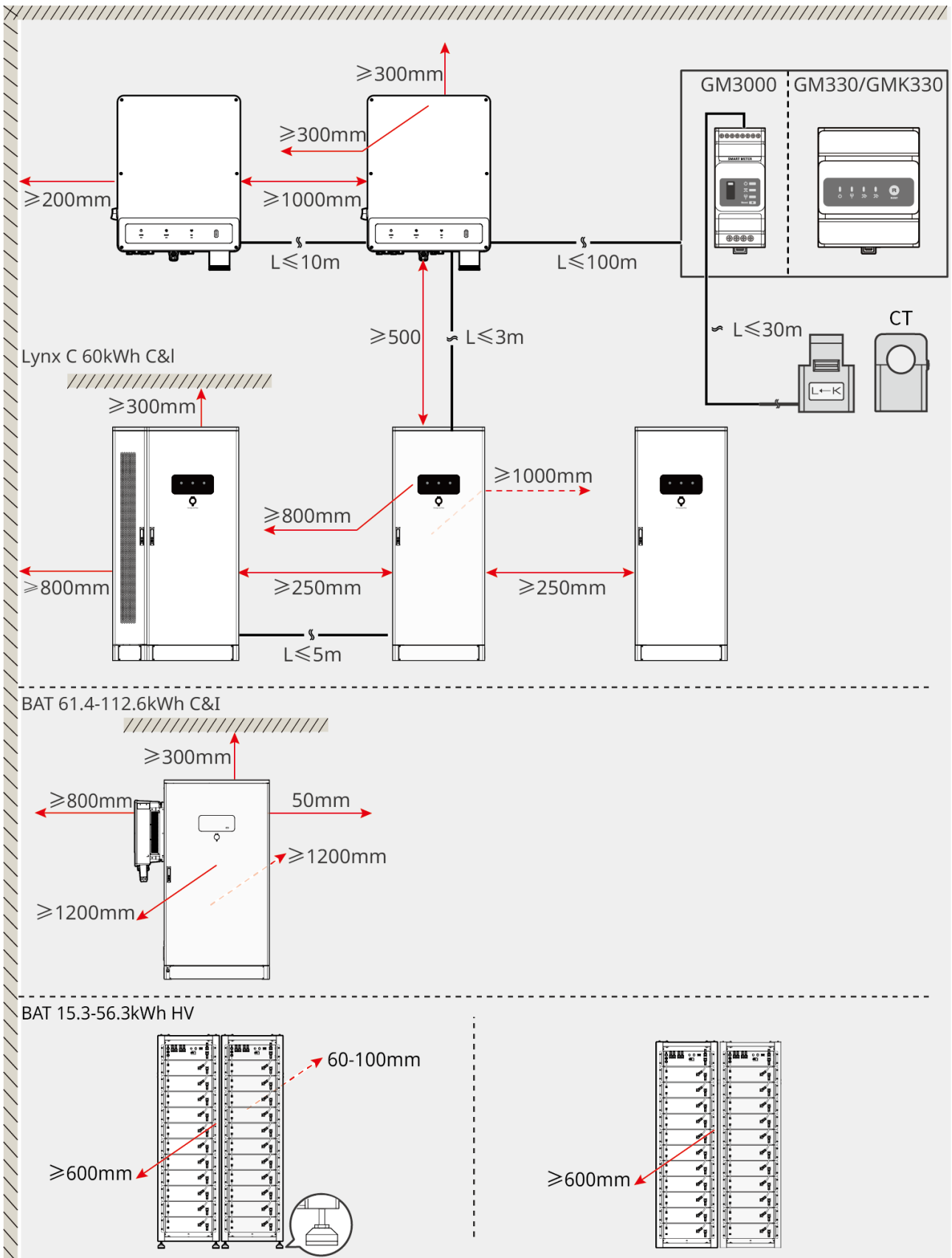
LXC6010INT0001

### 4.2.3 Installation Space Requirements

When installing devices in the system, sufficient space should be reserved around the devices to ensure adequate installation and heat dissipation space.

#### NOTICE

The specific numerical value for the battery installation space can be adjusted based on the actual installation scenario and local regulations.



ET3010INT0008


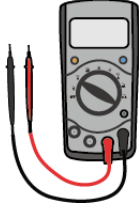
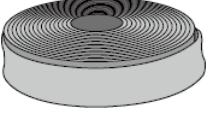

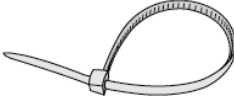


## 4.2.4 Tool Requirements

### NOTICE


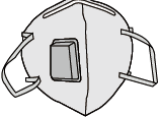


During installation, it is recommended to use the following installation tools. If necessary, other auxiliary tools can be used on-site.

### Installation Tools

Tool Type	Description	Tool Type	Description
	diagonal plier		RJ45 connector crimping tool
	wire stripper		YQK-70 hydraulic pliers
	VXC9 hydraulic pliers		Level bar
	open-end wrench		PV terminal crimping tool PV-CZM-61100
	hammer drill (bit Φ8mm)		torque wrench M5/M6/M8/M12/M16/ M18/M22
	rubber hammer		socket wrench

Tool Type	Description	Tool Type	Description
	marker pen		multimeter Range $\leq 1100V$
	heat shrink tubing		hot air gun
	cable tie		vacuum cleaner
	Level bar		

### personal protective equipment

Tool Type	Description	Tool Type	Description
	Insulated gloves, protective gloves		Dust mask
	goggle		Safety shoes

## 4.3 Equipment Handling

## WARNING

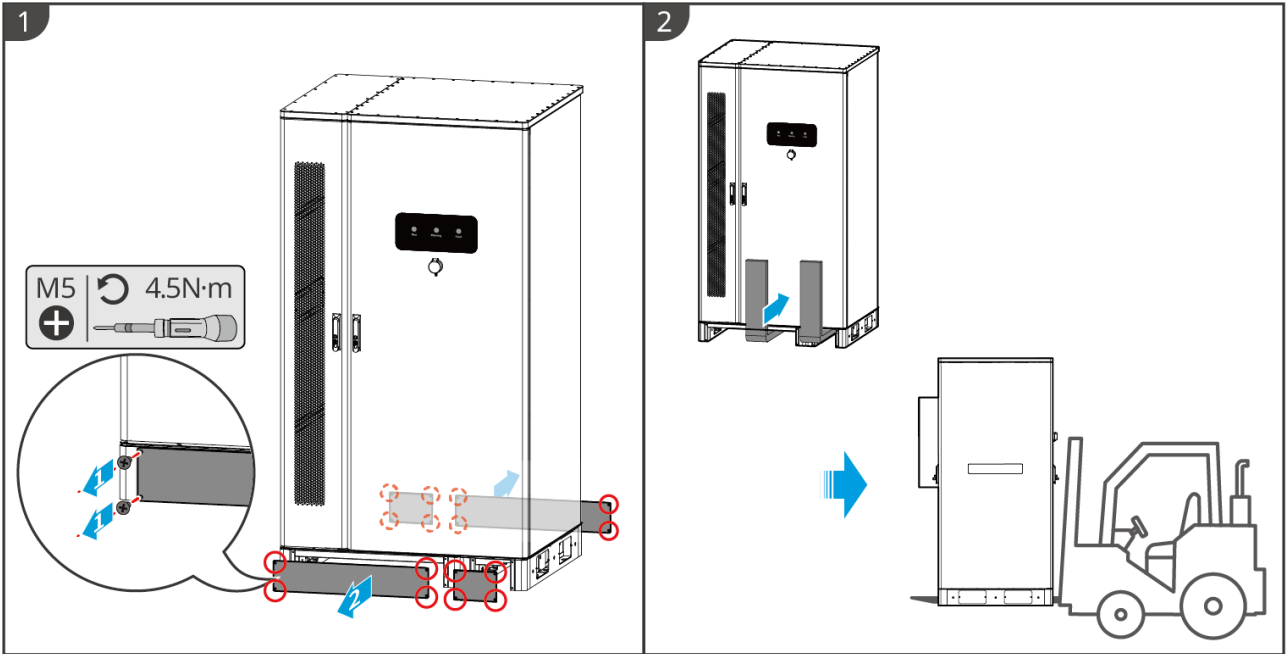
1. During operations such as transportation, handling, and installation, it is necessary to comply with the laws, regulations, and relevant standard requirements of the country or region.
2. Before installation, the equipment must be moved to the installation site. To prevent personal injury or equipment damage during the moving process, please note the following:
  - Ensure an adequate number of personnel corresponding to the equipment weight to avoid exceeding the human lifting capacity, which could cause injury from dropping.
  - Wear safety gloves to prevent injury.
  - Ensure the equipment remains balanced during movement to avoid dropping and tipping over.
  - During movement, ensure the cabinet doors are securely locked.

## NOTICE

- The device can be transported to the installation site via hoisting or forklift.
- When using hoisting to move the device, please use flexible slings or straps, with a single strap load-bearing capacity of  $\geq 2t$ .
- When using a forklift to move the device, the forklift's load-bearing capacity must be  $\geq 2t$ .

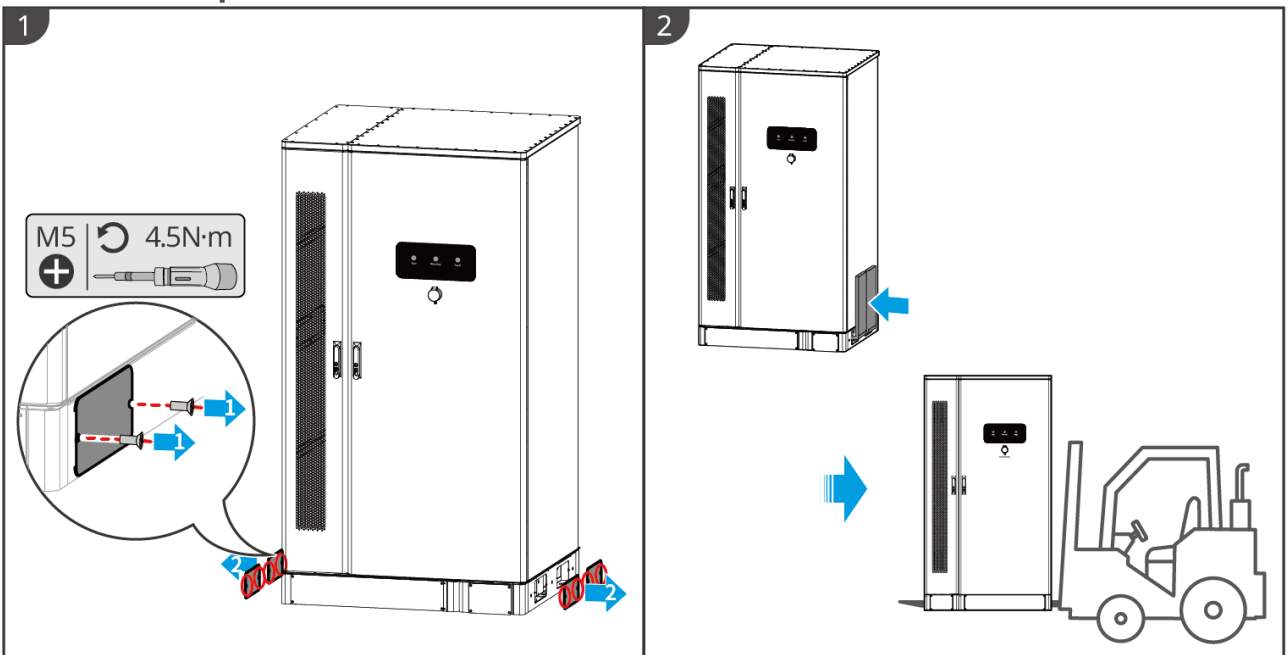
### • Lynx C Series 60kWh C&I Battery System

#### Forklift Transport Method One



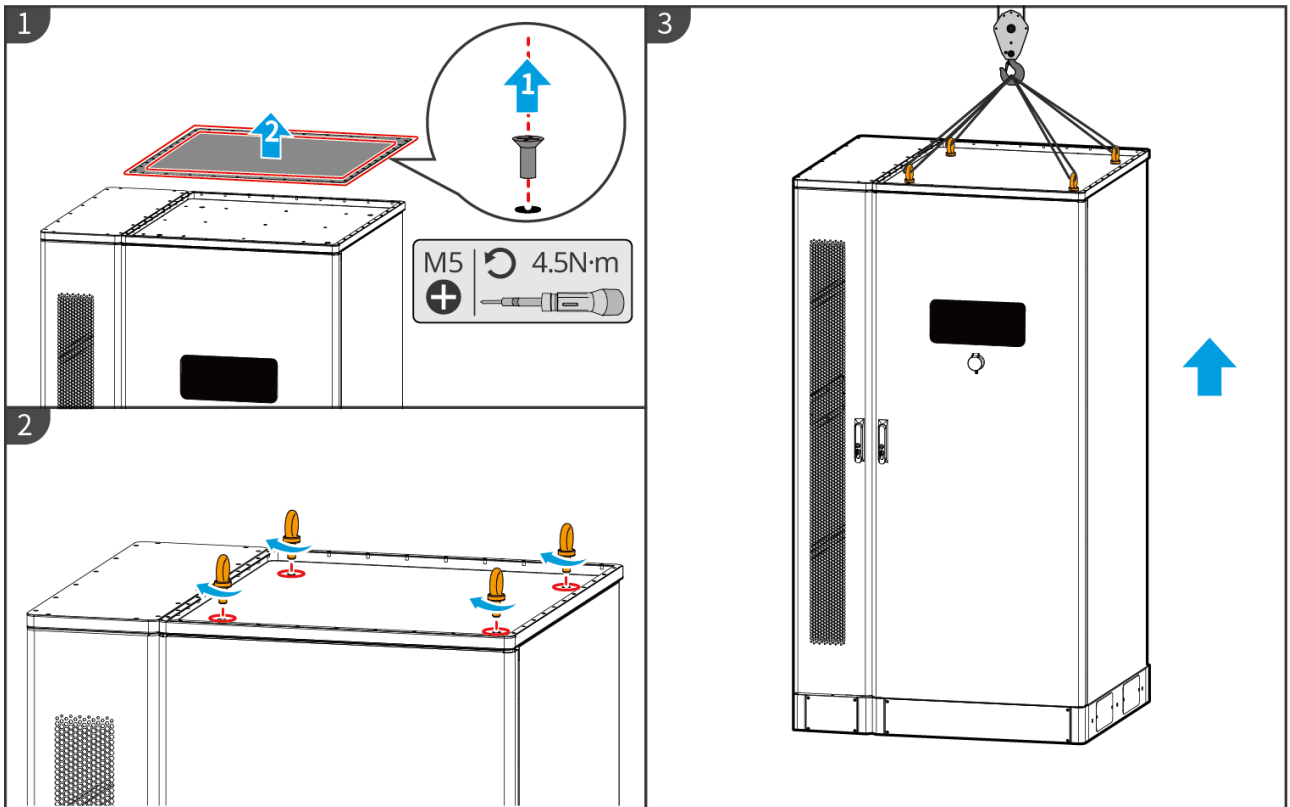
LXC6010INT0002

### Forklift Transport Method Two



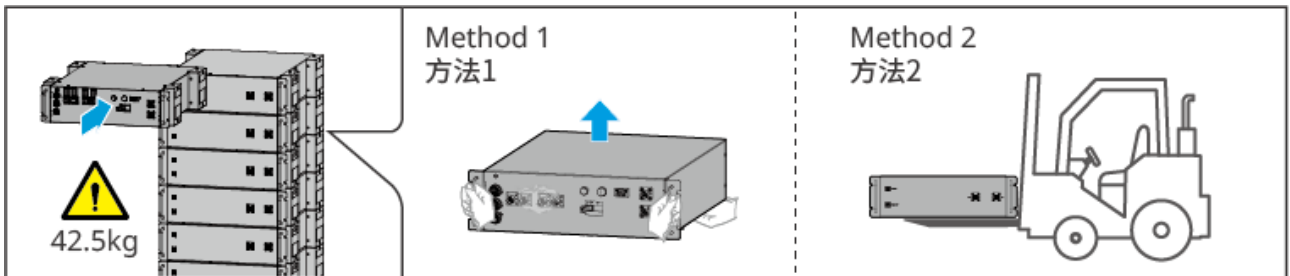
LXC6010INT0003

### Hoisting Transport:



LXC6010INT0004

• **BAT-S Series 15.3-56.3kWh High Voltage Battery**

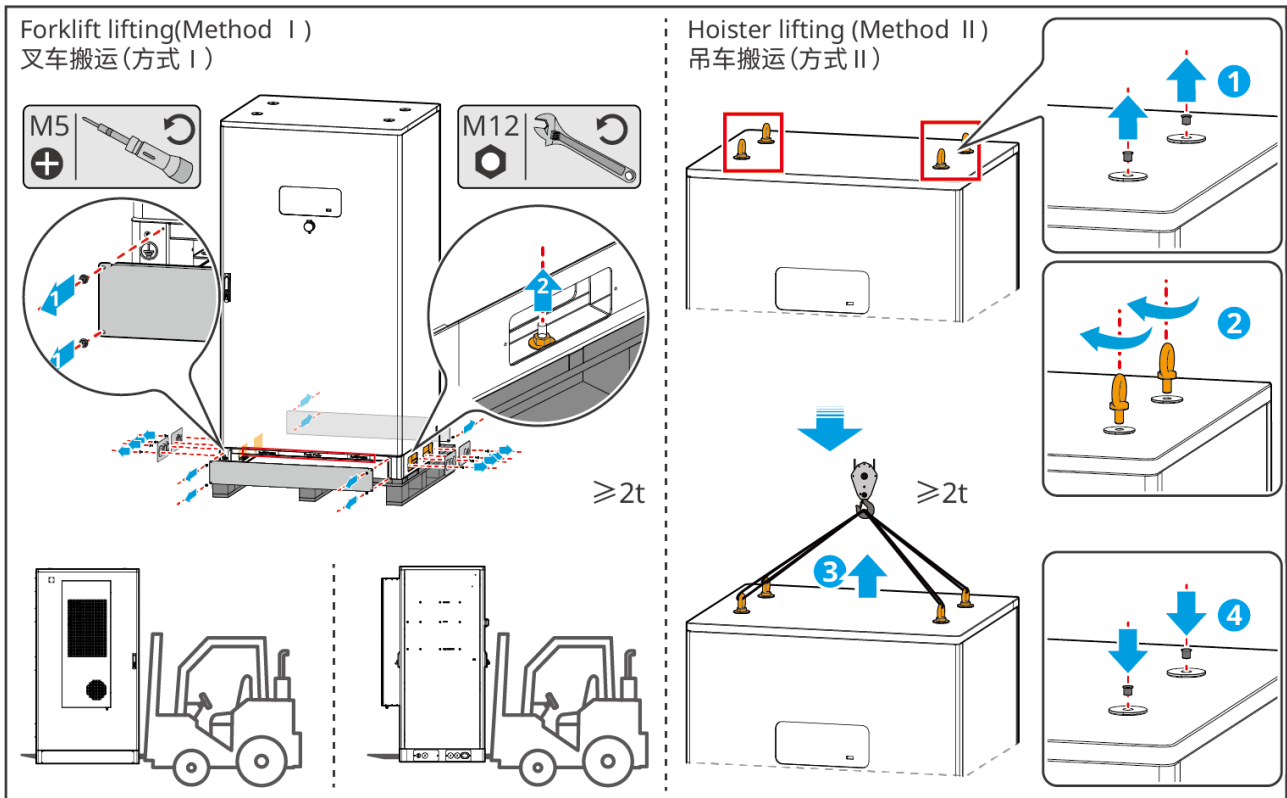


BAT10INT0032

• **BAT-C Series 61.4-112.6kWh C&I Battery System**

**NOTICE**

- Remove the baffle before transporting the equipment with a forklift.
- The battery system is secured to the pallet with bottom screws during shipment. Remove the pallet before installation.



BAT10INT0003

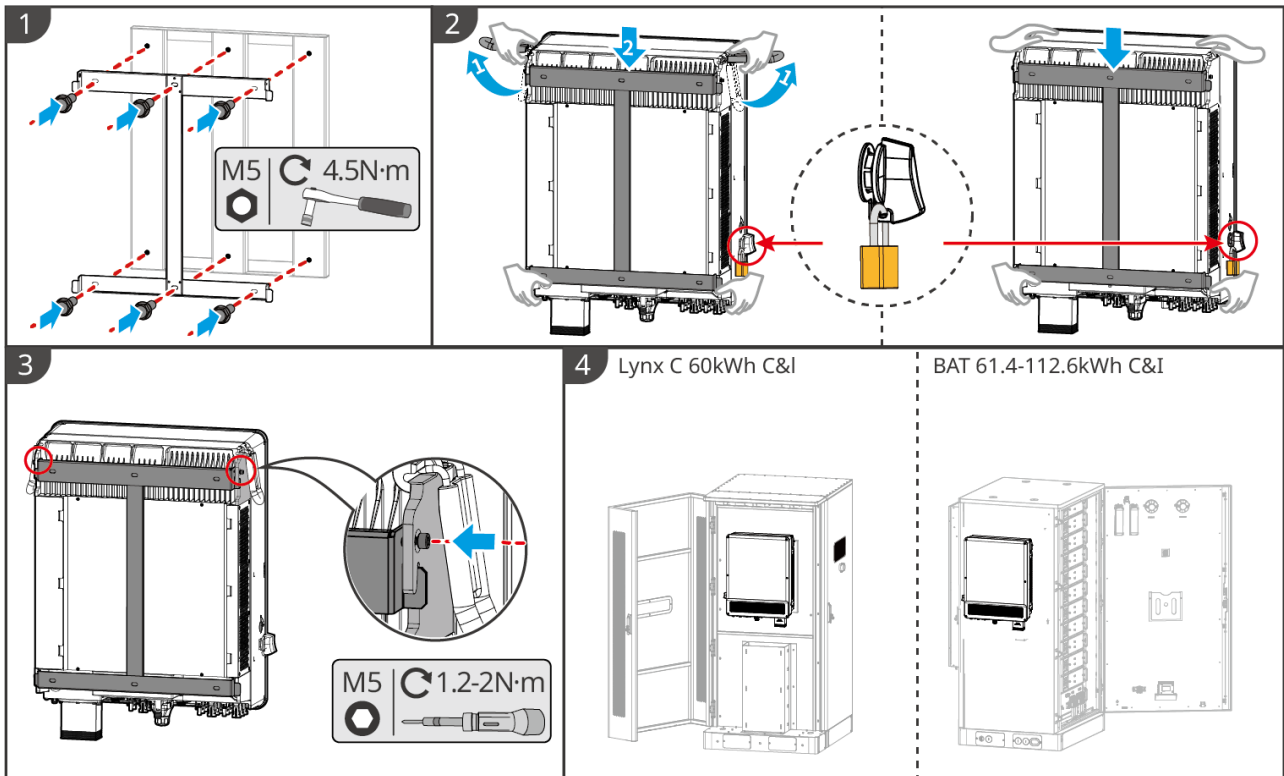
## 4.4 Installing the Inverter

The inverter is installed in the battery system cabinet

### ⚠ CAUTION

Ensure the inverter is installed securely to prevent it from falling and causing injury.

1. Fix the inverter back mounting bracket to the battery system cabinet.
2. (Optional) Use a DC switch lock to lock the DC switch in the "OFF" state, and hang the inverter on the backplate. The DC switch lock is user-provided; please ensure the aperture of the DC switch lock meets the requirements.
3. Tighten the screws on both sides to secure the backplate and the inverter, ensuring the inverter is installed firmly.



ET3010INT0006

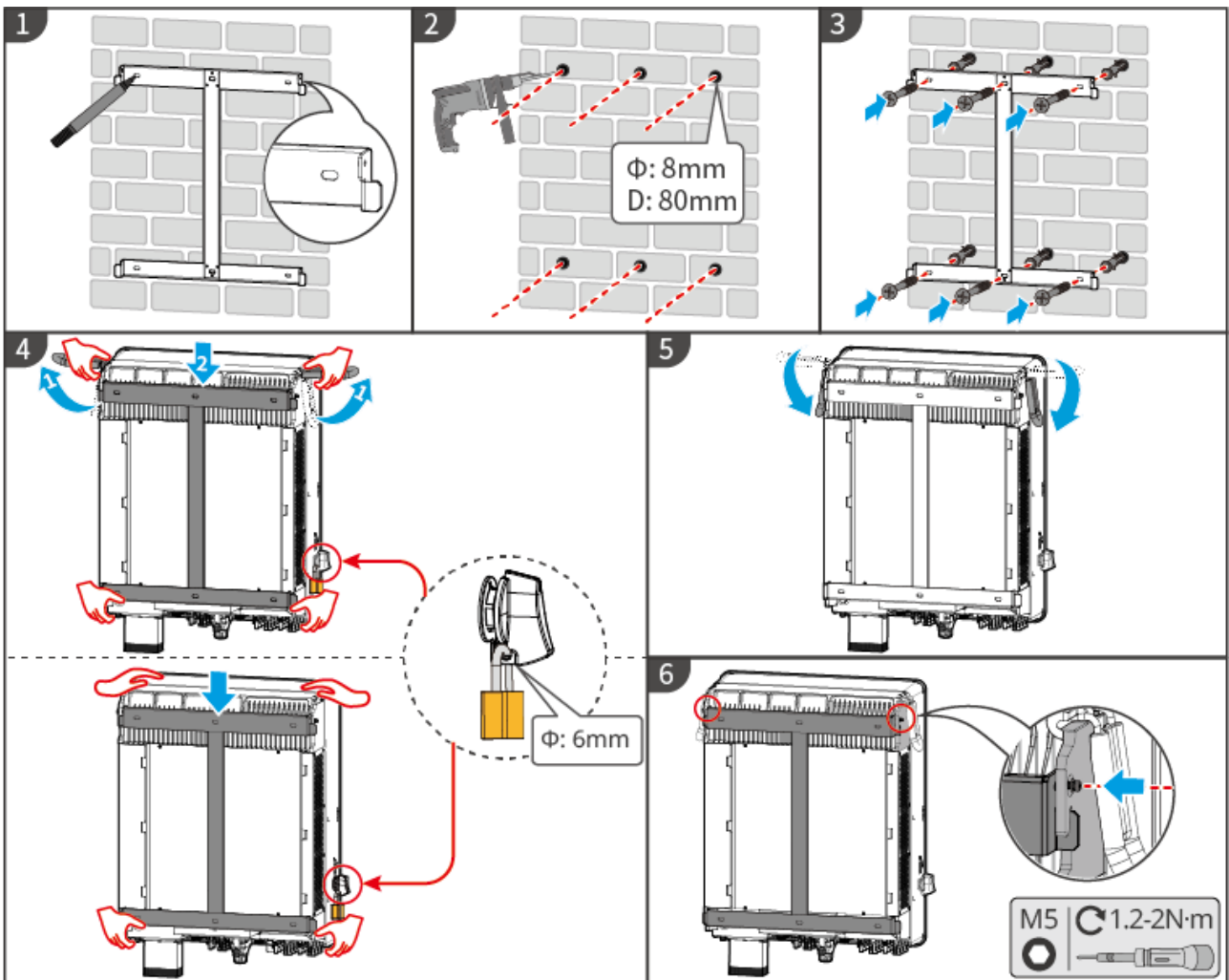
## The inverter is installed on the wall

### CAUTION

- When drilling, ensure the drilling location avoids water pipes, cables, etc. inside the wall to prevent danger.
- When drilling, please wear safety goggles and a dust mask to avoid inhaling dust into the respiratory tract or getting it into the eyes.
- Ensure the inverter is securely installed to prevent it from falling and injuring personnel.

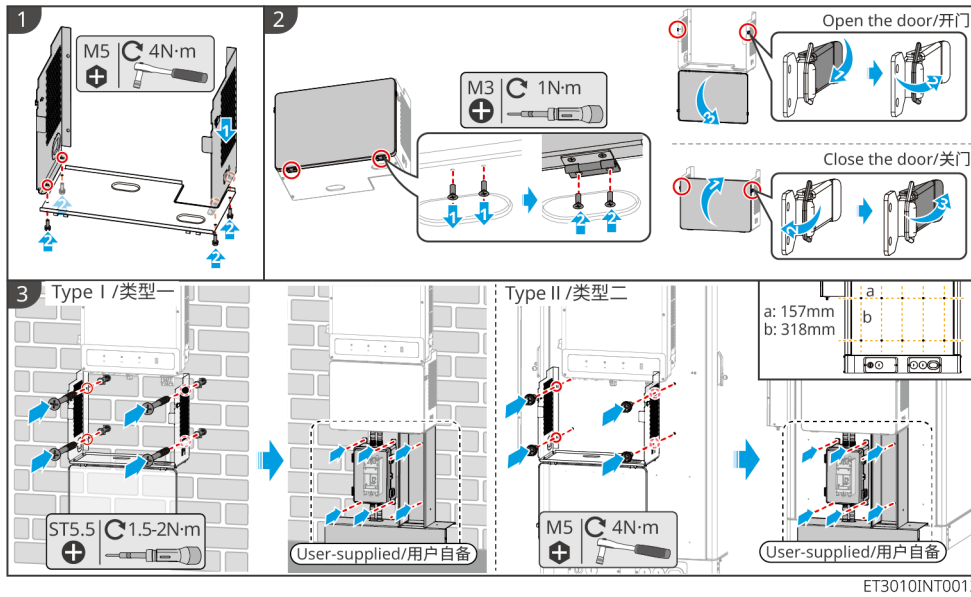
1. Place the back mounting plate horizontally on the wall, and use a marker to mark the drilling positions.
2. Use an impact drill to drill holes.
3. Use expansion screws to fix the inverter back mounting bracket to the wall.
4. Use a DC switch lock to lock the DC switch in the "OFF" state, and hang the inverter on the backplate. (Optional) For Australia only, the DC switch lock is user-provided; please ensure the aperture of the DC switch lock meets the requirements.
5. (Optional) Lower the handle.

6. Tighten the screws on both sides to secure the backplate and the inverter, ensuring the inverter is installed firmly.



ET3010INT0002

### Installing the Protective Cover (Australia Only)

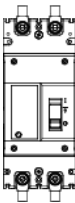


ET3010INT0012

**Step1:** Assemble the protective cover.

**Step2:** Install the front cover.

**Step3:** Fix the protective cover to the wall/side of the battery cabinet, and install the circuit breaker, waterproof box, and bridge according to local regulations. For specific requirements, please refer to the table below.

Equipment		Recommended Model/Specification	Description
break er		Select according to local laws and regulations <ul style="list-style-type: none"> <li>• 2P DC switch</li> <li>• Rated Current <math>\geq 63A</math></li> <li>• Nominal Voltage <math>\geq 1000V</math></li> </ul>	To be prepared by the user.

Equipment		Recommended Model/Specification	Description
Water proof Enclosure		<p>Ingress Protection Rating &gt; IP65 Hole Spacing Requirements:</p> <ul style="list-style-type: none"> <li>• Left-right hole spacing: 157mm</li> <li>• Top-bottom hole spacing: 318mm</li> </ul> <p>Style and dimensions are for reference only.</p>	<p>To be prepared by the user.</p> <p>If the hole spacing of the waterproof enclosure does not meet the requirements and it cannot be fixed to the battery cabinet, please prepare a mounting plate. First, drill holes in the mounting plate as required and fix it to the battery cabinet, then fix the waterproof enclosure onto the mounting plate.</p>
Bridge /Frame		<p>a: 250mm b: 150mm c: 510mm</p> <p>Style is for reference only.</p>	<p>To be prepared by the user.</p>

## 4.5 Installing the Battery System



**WARNING**

- Before installation, check that the ground is flat and level.
- Ensure the energy storage system is vertical and firmly placed on the ground to prevent tipping.

### 4.5.1 Open the Cabinet Door

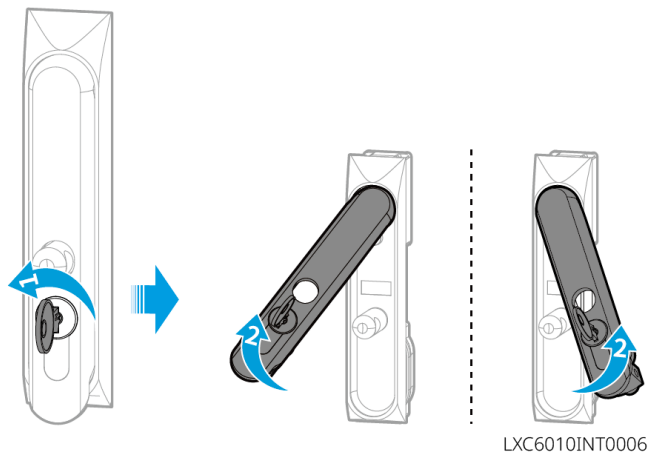
**!WARNING**

- Do not open the cabinet door during handling and installation.
- Close the cabinet door after the system installation, wiring, and commissioning are completed.

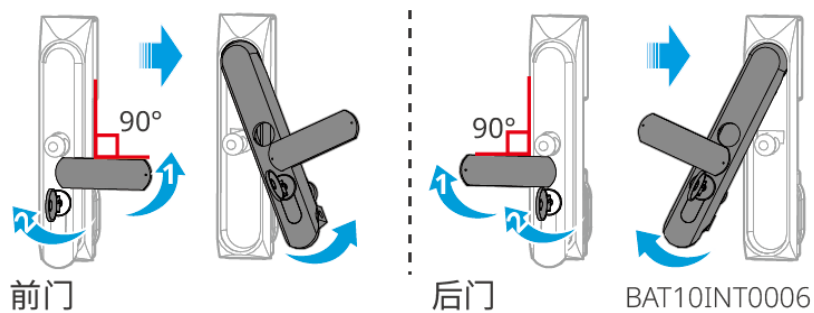
**Step 1:** Use the key to unlock the cabinet door.

**Step 2:** Turn the door handle to open the cabinet door.

• **Lynx C Series 60kWh Commercial & Industrial Battery System**



• **BAT Series 61.4-112.6kWh Commercial & Industrial Battery System**

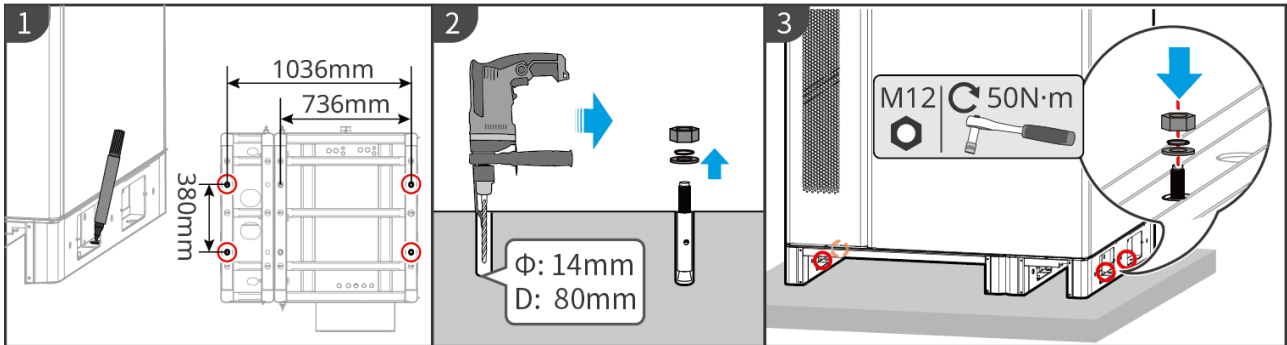


### 4.5.2 Installing the Lynx C Series 60kWh Commercial & Industrial Battery System

**Step 1:** Use a marker pen to mark the drilling positions on the level ground.

**Step 2:** Use an impact drill with a 14mm diameter drill bit to create holes approximately 80mm deep, and install expansion bolts.

**Step 3:** Move the battery system into position over the holes and tighten the expansion bolts using a socket wrench.



LXC6010INT0005

### 4.5.3 Installation of BAT-S Series 15.3-56.3kWh High-Voltage Battery

#### • Stacked Installation

**Step 1:** Install adjustable feet under the base, with an adjustable height range of 35-45mm.

**Step 2:** Secure the floor lock bracket to the base.

**Step 3:** Use a pen to mark the drilling positions for expansion bolts on the ground.

**Step 4:** Install the expansion bolts.

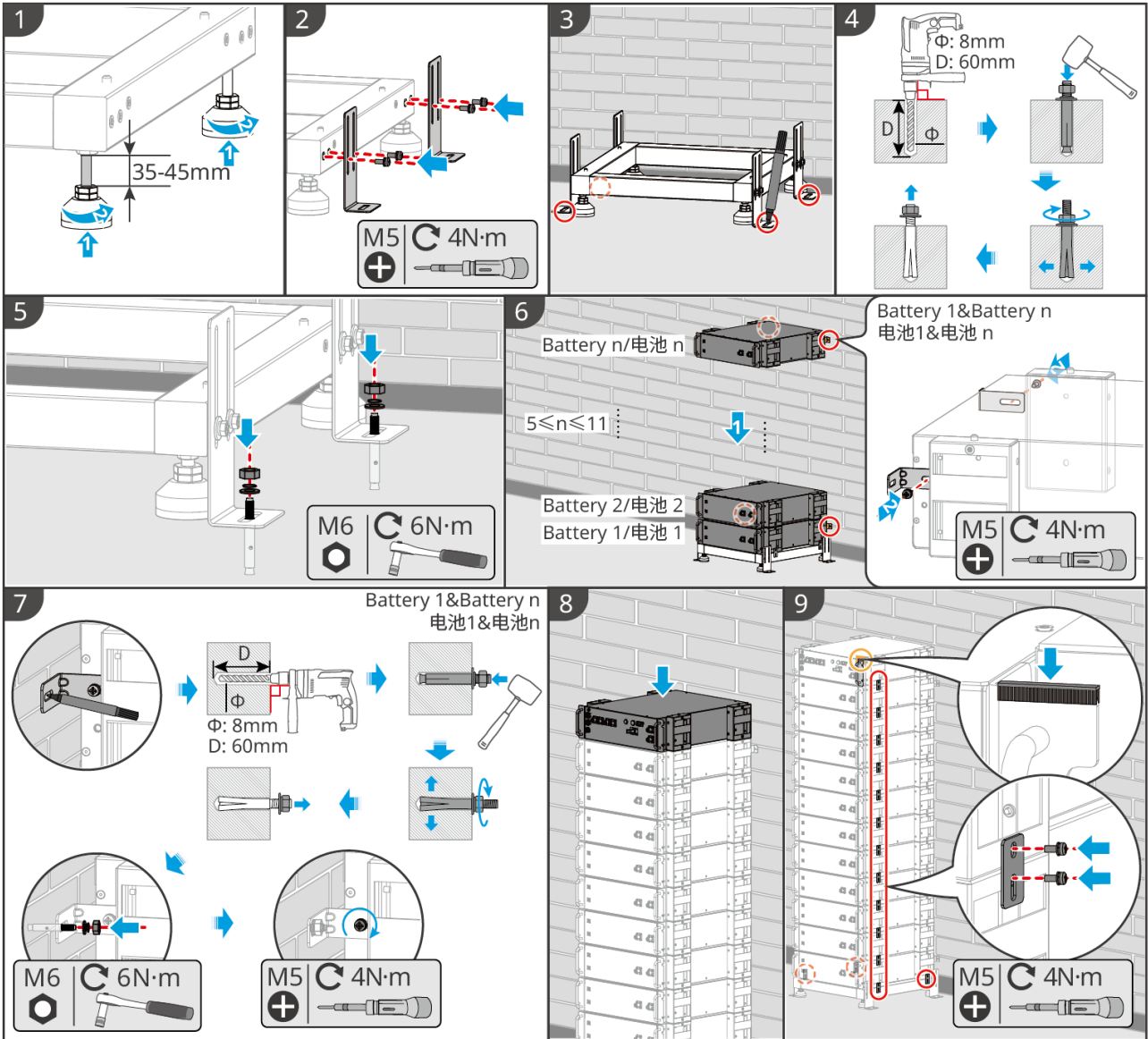
**Step 5:** Fix the floor lock bracket to the ground using expansion bolts.

**Step 6:** Stack the battery PACKs, and pre-tighten the wall lock brackets on the first and last battery PACKs.

**Step 7:** Use a pen to mark the drilling positions for expansion bolts on the wall, fix the wall lock brackets with expansion bolts, and then tighten the wall lock brackets on the battery PACKs.

**Step 8:** Place the high-voltage box.

**Step 9:** Install the equipotential bonding strip and wire protection sleeves.



BAT10INT0021

## • Battery Rack Installation

### Installing the Battery Rack

**Step1:** Lay the bracket flat, align the holes according to the serial number silkscreen, and secure with M5 screws.

**Step2:** Place the rack vertically according to the arrow markings.

### Securing the Battery Cabinet

#### • Type I

**Step3:** Use a marker pen to mark the drilling positions for expansion bolts on the level ground.

**Step4:** Install the expansion bolts, and fix the battery rack to the level ground using expansion bolts.

- **Type II**

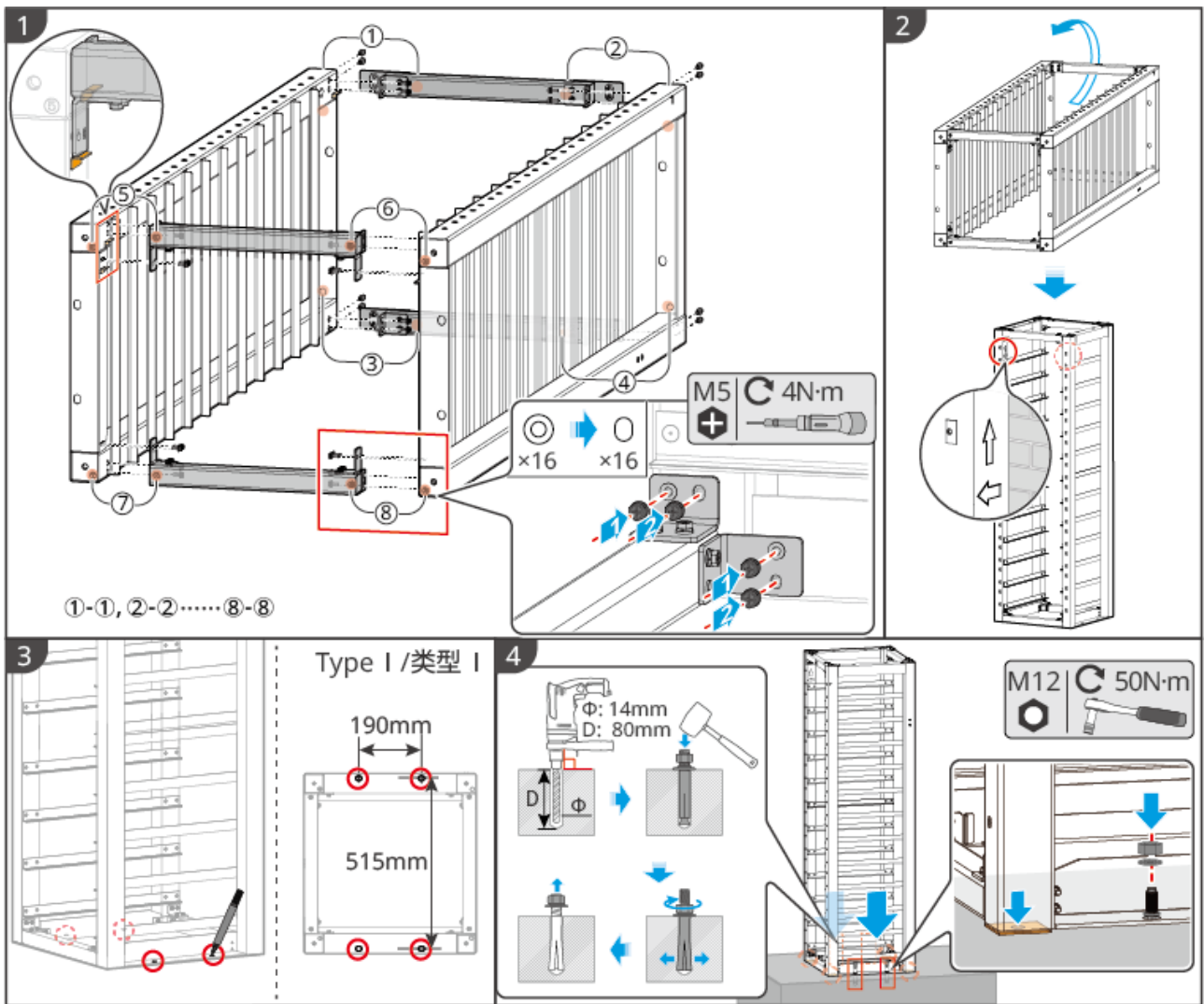
**Step3:** Lay the rack horizontally and install adjustable feet at the bottom of the rack.

**Step4:** Place the rack vertically, and secure the rack to the wall using wall lock brackets.

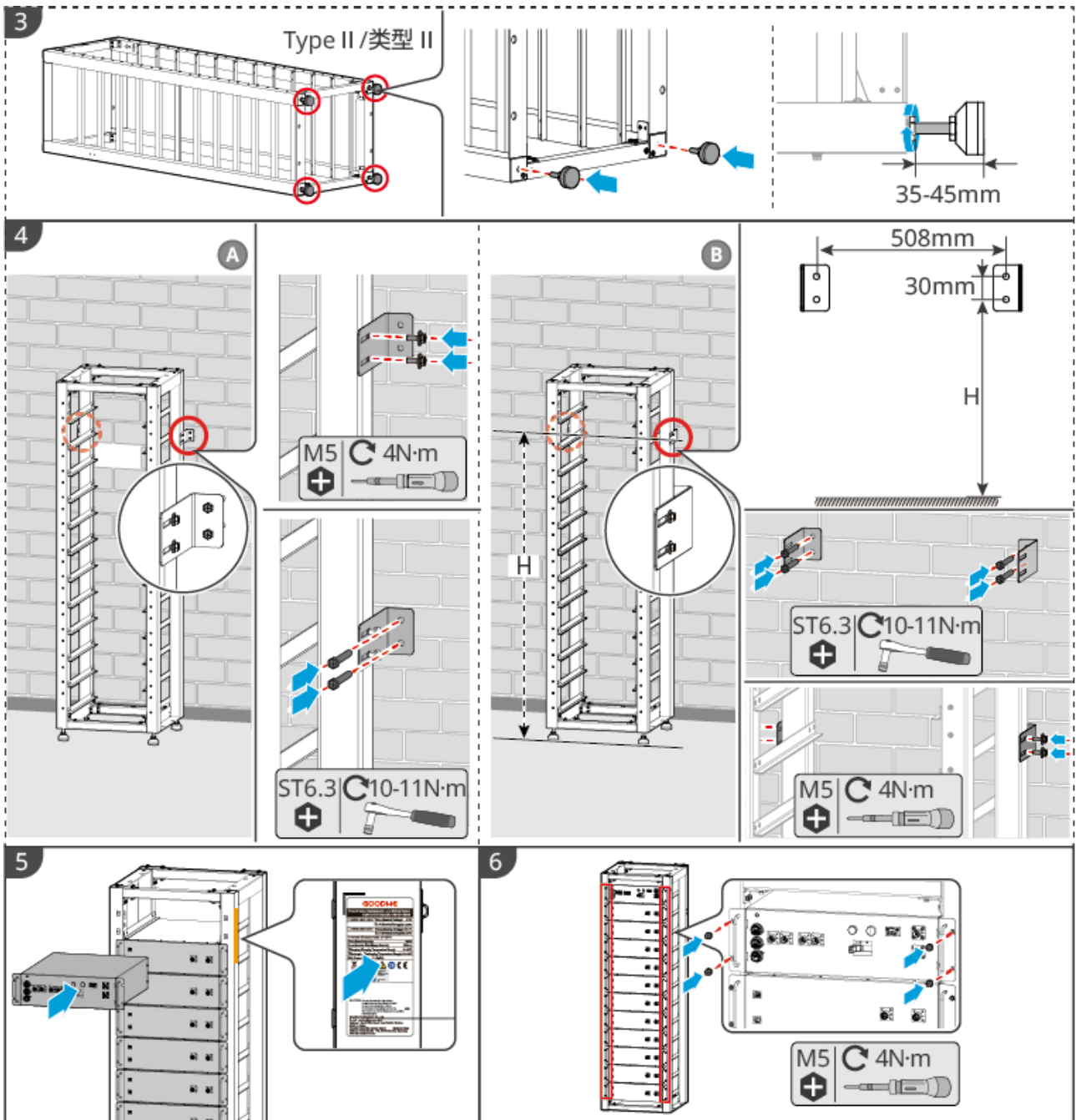
### **Installing the High-Voltage Box and Battery PACK**

**Step5:** Push the high-voltage box and battery PACKs into the rack in sequence, and attach labels to the side of the rack.

**Step6:** Secure the high-voltage box and battery PACKs with M5 screws.



BAT10INT0020



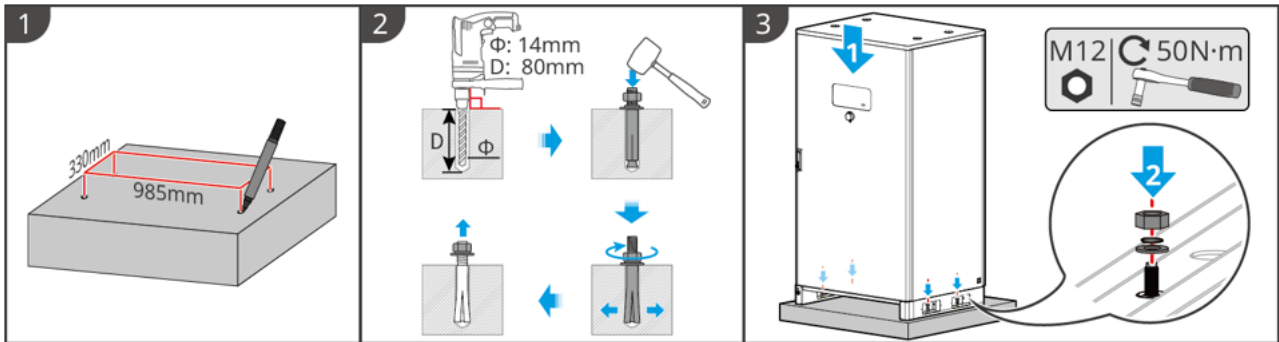
BAT10INT0031

#### 4.5.4 Installing the BAT Series 61.4-112.6kWh Commercial & Industrial Battery System

**Step 1:** Secure the battery system to the foundation.

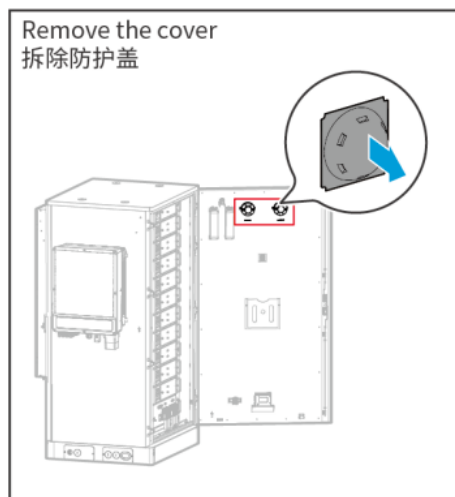
1. Mark the drilling positions according to the dimensions shown in the diagram.
2. Use an impact drill to create holes and install expansion bolts.

3. Move the battery rack to the hole positions and secure the battery to the foundation using the expansion bolts.



BAT10INT0005

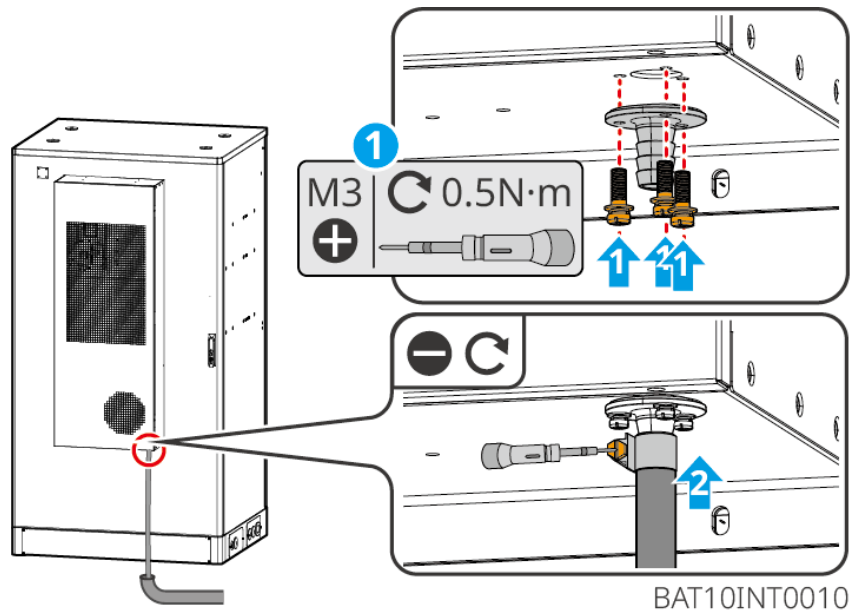
**Step 2:** Remove the protective covers from the smoke and temperature sensor alarms. The battery is shipped with protective covers on the smoke and temperature sensor alarms. These covers must be removed for the alarms to function properly.



BAT10INT0016

**Step 3:** Install the air conditioner drain pipe.

1. Install the air conditioner drain pipe connector.
2. Secure the air conditioner drain pipe to the connector.

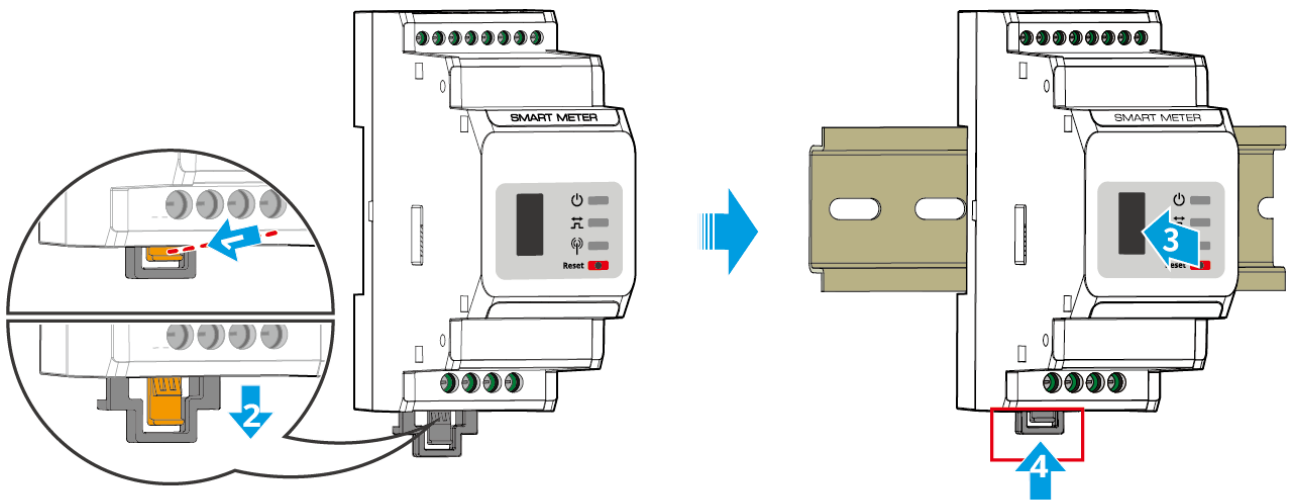


## 4.6 Installing the Smart Meter

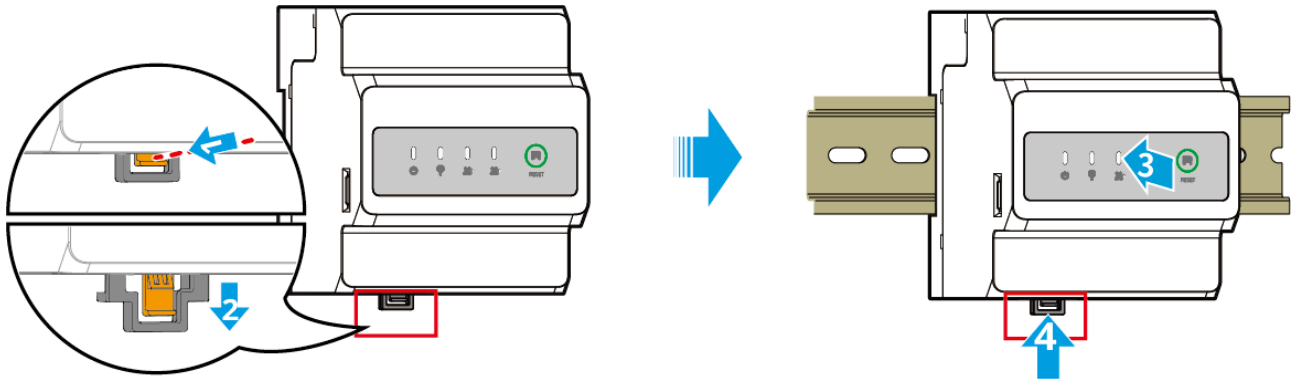
### ! WARNING

In areas with lightning danger, if the meter cable length exceeds 10m and the cable is not laid in grounded metal conduits, it is recommended to install external lightning protection devices.

### GM3000



### GM330&GMK330



GMK10INT003

# 5 System Wirings

## DANGER

- The erection, routing, and connection of cables must comply with local laws, regulations, and code requirements.
- All operations during electrical connection, as well as the specifications of cables and components used, must meet local legal and regulatory requirements.
- Before performing electrical connections, disconnect the DC switch and AC output switch of the equipment to ensure the equipment is powered off. Live-line work is strictly prohibited, as it may lead to dangers such as electric shock.
- Cables of the same type should be bundled together and arranged separately from different types of cables. Intertwining or cross-arrangement is prohibited.
- If the cable is subjected to excessive tension, poor connections may occur. When connecting, leave a certain length of cable slack before connecting it to the inverter terminal ports.
- When crimping terminals, ensure the conductor part of the cable makes full contact with the terminal. Do not crimp the cable insulation together with the terminal. Otherwise, it may cause equipment malfunction, or after operation, unreliable connections leading to heating, which could damage the inverter terminal block.

## NOTICE

- When performing electrical connections, wear personal protective equipment such as safety shoes, protective gloves, and insulating gloves as required.
- Only qualified personnel are permitted to perform electrical connection operations.
- The cable colors in the diagrams of this document are for reference only. Specific cable specifications must comply with local regulatory requirements.
- For parallel systems, please adhere to the safety precautions in the user manuals corresponding to the relevant products within the system.

## 5.1 System Wiring Electrical Block Diagram

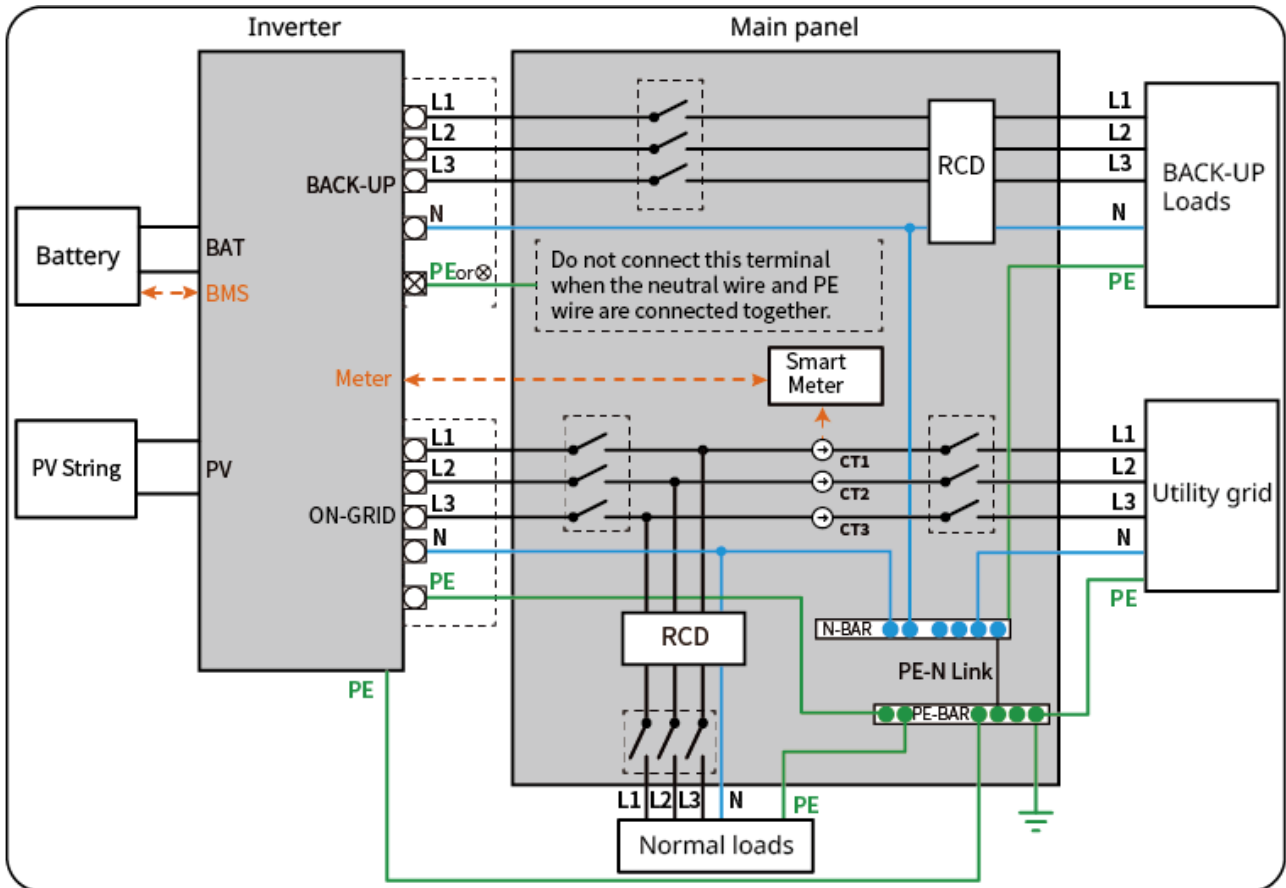
## NOTICE

- Depending on regional regulatory requirements, the wiring methods for the N and PE lines of the inverter's ON-GRID and BACK-UP ports differ. Please follow the specific local regulations.
- The inverter's ON-GRID AC port has a built-in relay. When the inverter operates in off-grid mode, the built-in ON-GRID relay is open; when the inverter operates in grid-connected mode, the built-in ON-GRID relay is closed.
- The BACK-UP AC port is live after the inverter is powered on. If maintenance is required on the BACK-UP Loads, power down the inverter first to avoid the risk of electric shock.

### **N and PE wires are connected together in the distribution box**

## NOTICE

- To maintain neutral integrity, the neutral wires on the grid-tied side and the off-grid side must be connected together; otherwise, the off-grid function cannot operate normally.
- The diagram below illustrates the grid system for regions such as Australia and New Zealand:

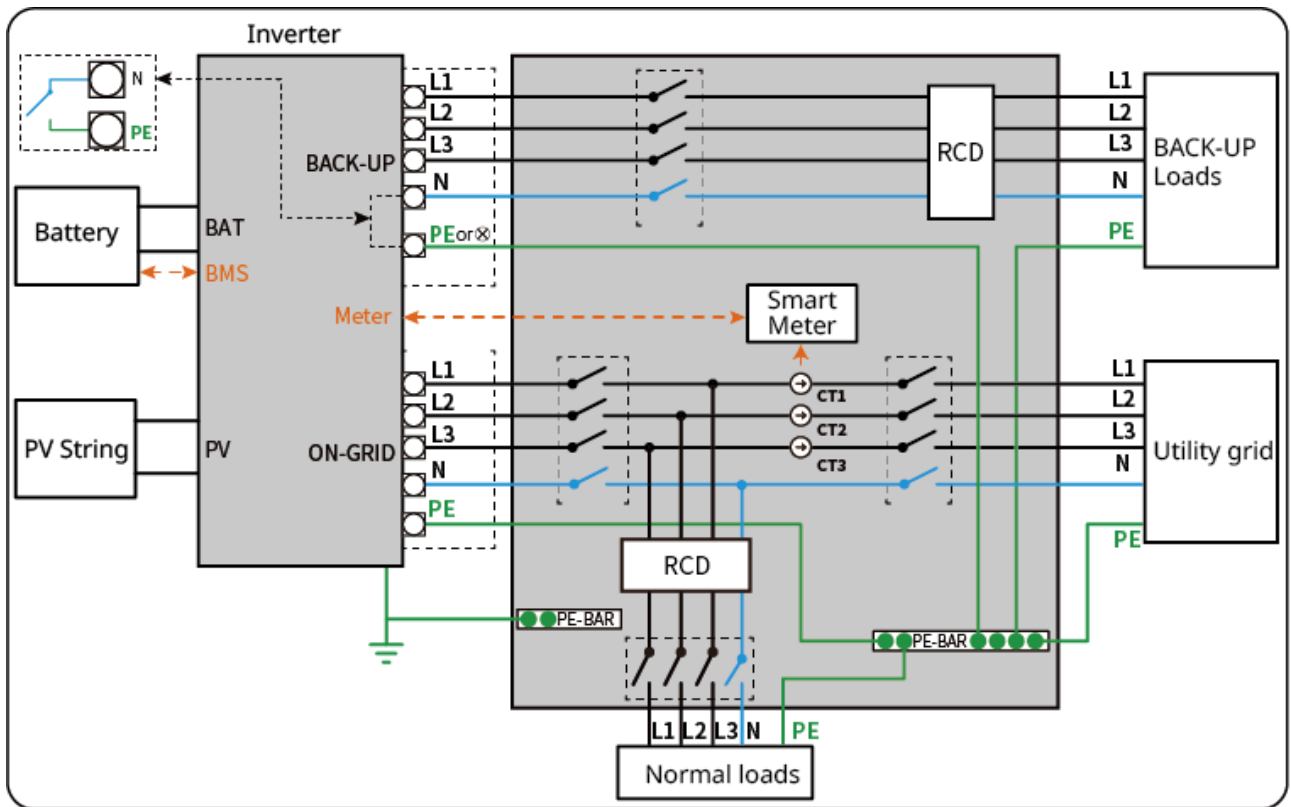


ET3010NET0015

### N and PE wires are connected separately in the distribution box

#### NOTICE

- Ensure the protective ground wire for the BACK-UP is correctly and securely connected. Otherwise, the BACK-UP function may operate abnormally in the event of a grid fault.
- The following wiring method applies to regions other than Australia, New Zealand, etc.:



ET3010NET0016

## 5.2 Detailed System Wiring Diagram

When all loads in the photovoltaic system cannot consume the electricity generated by the system, the surplus power will be fed back into the grid. In this case, a smart meter or CT monitoring system can be used to monitor the system's power generation and control the amount of electricity fed into the grid.

- Connecting a smart meter enables output power limiting and load monitoring functions.
- After connecting the smart meter, please enable the "Export power limit" function via the SolarGo App.

The Detailed System Wiring Diagram only shows wiring examples using some device models. Please refer to the corresponding wiring guide chapters for the actual devices you are using.

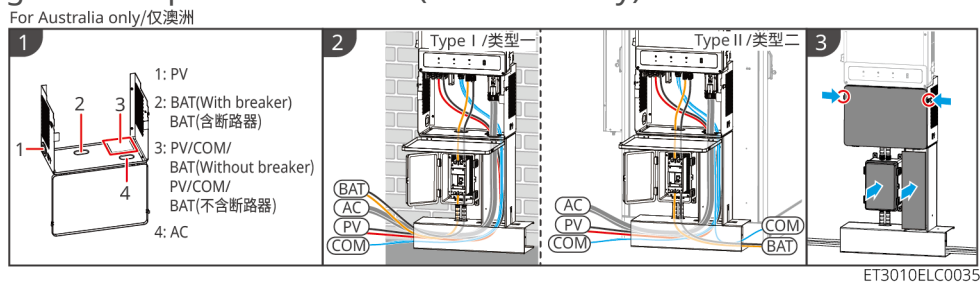
## NOTICE

- In coupling scenarios, if grid-connected inverter power generation monitoring and load monitoring functions are required, dual meter networking must be used.
  - Meter 1 is used to monitor the system's grid-connected power.
  - Meter 2 is used to monitor the grid-connected inverter's power generation.
  - By integrating the data from Meter 1 and Meter 2, the monitoring platform can achieve real-time monitoring of load power consumption.
- If the grid-connected inverter requires output power limitation, please connect a meter or CT device separately.

### Dual Meter Configuration Scenarios

Meter1 (Grid Side)	Meter2 (Grid-tied Inverter AC Side)
GM3000	GM3000
GM3000	GM330
GM3000	GMK330
GM330	GM330
GM330	GM3000
GM330	GMK330
GMK330	GMK330
GMK330	GM3000
GMK330	GM330

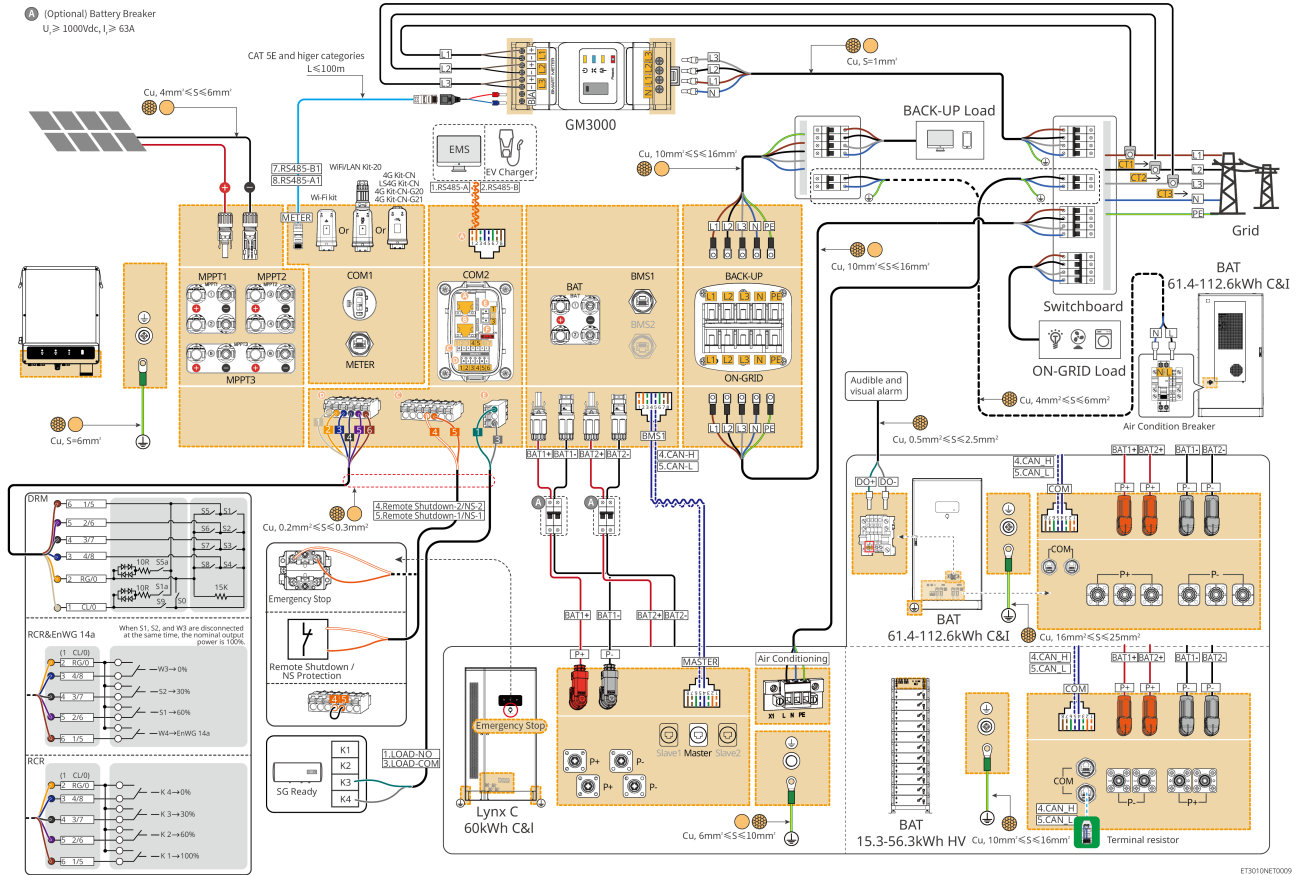
### Wiring diagram with protective cover (Australia only)



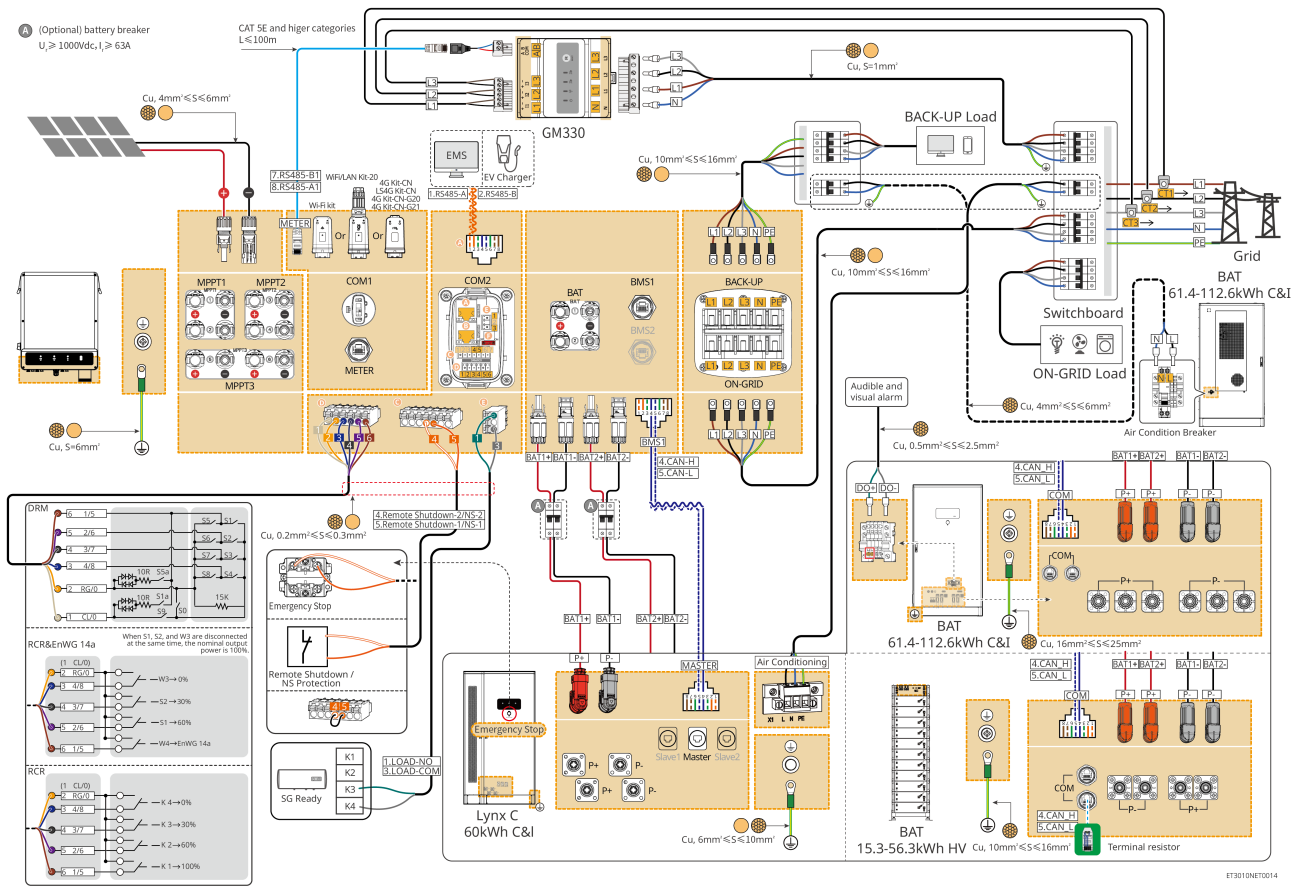
# 5.2.1 Detailed System Wiring Diagram for Single Inverter

## General Scenarios

### Scenario with GM3000

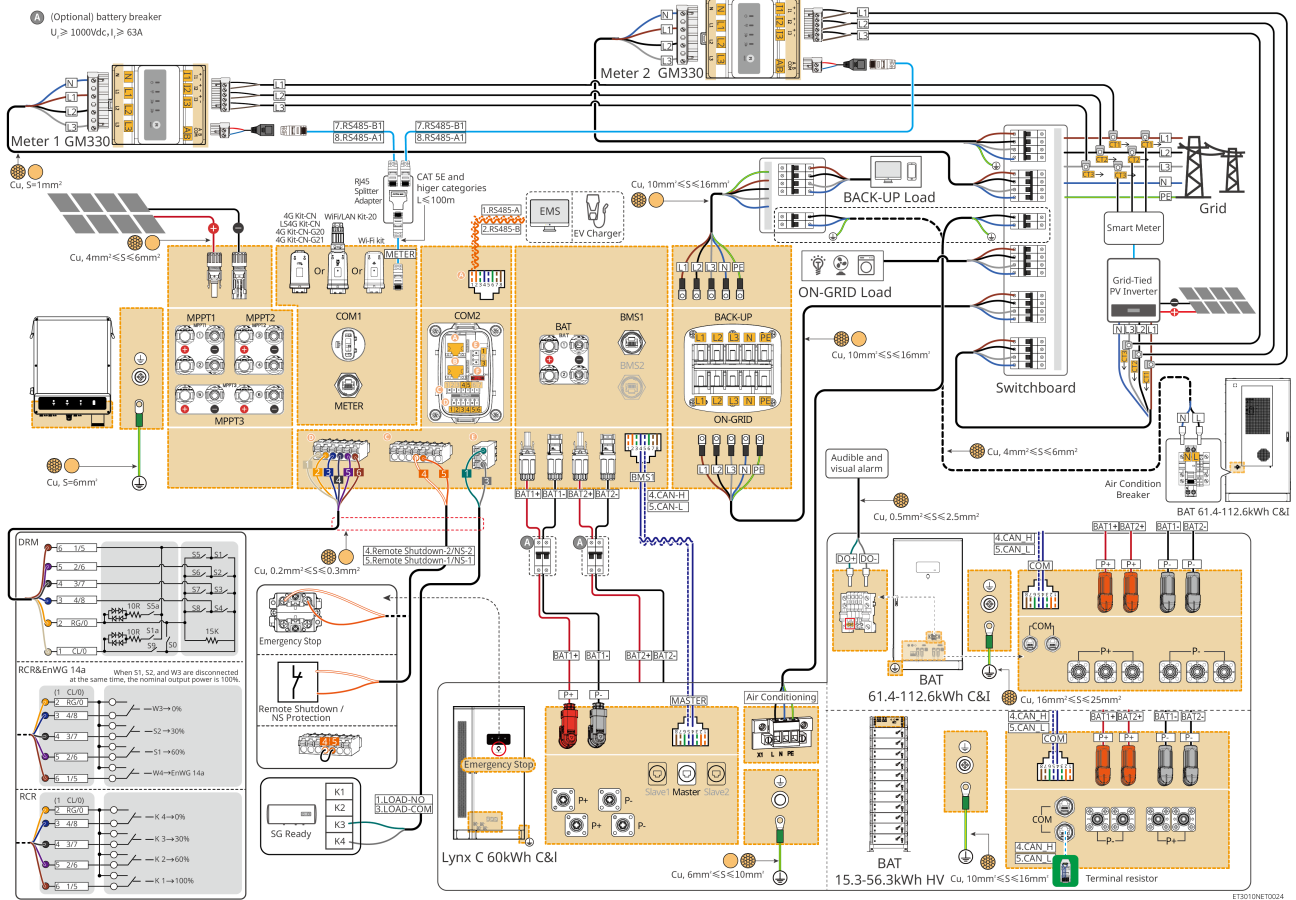


### Scenario with GM330



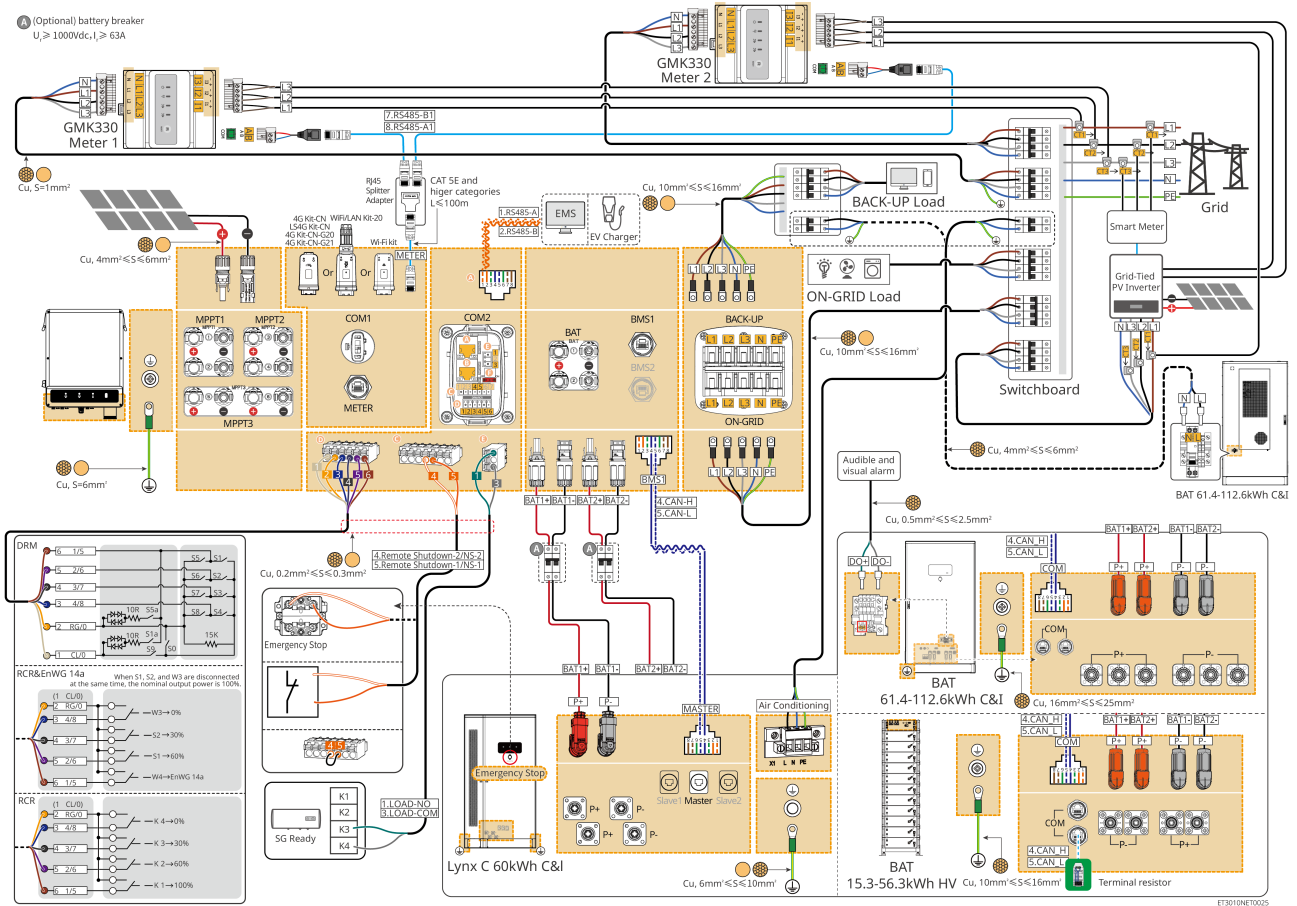
Scenario with GMK330





GMK330 meter +GMK330 meter

A (Optional) battery breaker  
 $U_{\geq 1000Vdc}, I_{\geq 63A}$



# 5.3 Preparing Materials

 **WARNING**

- Do not connect loads between the inverter and the AC switch directly connected to the inverter.
- Each inverter must be equipped with an AC output circuit breaker. Multiple inverters must not share one AC circuit breaker.
- To ensure the inverter can safely disconnect from the grid in case of an abnormality, please install an AC circuit breaker on the AC side of the inverter. Select an appropriate AC circuit breaker according to local regulations.
- When the inverter is powered on, the BACK-UP AC port is live. If maintenance on the BACK-UP Loads is required, power down the inverter first, otherwise electric shock may occur.
- For cables used in the same system, it is recommended that the conductor material, cross-sectional area, length, etc., be consistent for:
  - The BACK-UP AC cable of each inverter
  - The ON-GRID AC cable of each inverter
  - The power cable between the inverter and the battery
  - The power cable between batteries
- The system only supports connecting a generator via an ATS switch in a single-unit scenario to achieve switching between grid and generator power supply. The ATS switch is connected to the grid by default.

### 5.3.1 Preparing Breakers

No.	breaker	Recommended Specifications	Acquisition Method	Remarks
1	ON-GRID breaker	<p>When the BACK-UP port is not loaded, the Rated Current requirement is as follows:</p> <ul style="list-style-type: none"> <li>• GW15K-ET: Rated Current <math>\geq 32A</math>; Nominal Voltage <math>\geq 400V</math></li> <li>• GW20K-ET: Rated Current <math>\geq 40A</math>; Nominal Voltage <math>\geq 400V</math></li> <li>• GW25K-ET: Rated Current <math>\geq 50A</math>; Nominal Voltage <math>\geq 400V</math></li> <li>• GW29.9K-ET, GW30K-ET: Rated Current <math>\geq 63A</math>; Nominal Voltage <math>\geq 400V</math></li> <li>• GW12KL-ET: Rated Current <math>\geq 50A</math>; Nominal Voltage <math>\geq 230V</math></li> <li>• GW18KL-ET: Rated Current <math>\geq 63A</math>; Nominal Voltage <math>\geq 230V</math></li> </ul> <p>When the BACK-UP port is loaded, the Rated Current requirement is as follows:</p> <ul style="list-style-type: none"> <li>• GW15K-ET: Rated Current <math>\geq 50A</math>; Nominal Voltage <math>\geq 400V</math></li> <li>• GW20K-ET, GW25K-ET, GW29.9K-ET, GW30K-ET: Rated Current <math>\geq 63A</math>; Nominal Voltage <math>\geq 400V</math></li> <li>• GW12KL-ET, GW18KL-ET: Rated Current <math>\geq 63A</math>; Nominal Voltage <math>\geq 230V</math></li> </ul>	Self-provided	If the inverter's BACK-UP port is not used, a suitable breaker can be selected based on the AC maximum output current.

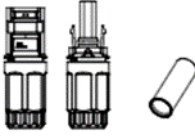
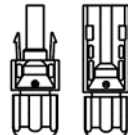
No.	breaker	Recommended Specifications	Acquisition Method	Remarks
2	BACK-UP breaker	<p>Nominal Voltage <math>\geq 400V</math>, Rated Current requirement is as follows:</p> <ul style="list-style-type: none"> <li>• GW15K-ET: Rated Current <math>\geq 32A</math>; Nominal Voltage <math>\geq 400V</math></li> <li>• GW20K-ET: Rated Current <math>\geq 40A</math>; Nominal Voltage <math>\geq 400V</math></li> <li>• GW25K-ET: Rated Current <math>\geq 50A</math>; Nominal Voltage <math>\geq 400V</math></li> <li>• GW29.9K-ET, GW30K-ET: Rated Current <math>\geq 63A</math>; Nominal Voltage <math>\geq 400V</math></li> <li>• GW12KL-ET: Rated Current <math>\geq 40A</math>; Nominal Voltage <math>\geq 230V</math></li> <li>• GW18KL-ET: Rated Current <math>\geq 63A</math>; Nominal Voltage <math>\geq 230V</math></li> </ul>	Self-provided	-

No.	breaker	Recommended Specifications	Acquisition Method	Remarks
3	ATS Switch	<p>The specifications of the ATS switch are consistent with the ON-GRID breaker for the same model. Specification requirements (recommended):</p> <ul style="list-style-type: none"> <li>• GW15K-ET: Rated Current <math>\geq 32A</math>;</li> <li>• GW20K-ET: Rated Current <math>\geq 40A</math>;</li> <li>• GW25K-ET: Rated Current <math>\geq 50A</math>;</li> <li>• GW29.9K-ET, GW30K-ET: Rated Current <math>\geq 63A</math>;</li> <li>• GW12KL-ET: Rated Current <math>\geq 40A</math>;</li> <li>• GW18KL-ET: Rated Current <math>\geq 63A</math>;</li> </ul>	Self-provided	During actual selection, you can also choose a breaker that complies with local installation regulations based on the actual operating current.
4	Battery Switch	<p>Select according to local laws and regulations</p> <ul style="list-style-type: none"> <li>• 2P DC Switch</li> <li>• Rated Current <math>\geq 63A</math></li> <li>• Nominal Voltage <math>\geq 1000V</math></li> </ul>	Self-provided	-

No.	breaker	Recommended Specifications	Acquisition Method	Remarks
5	RCD	Select according to local laws and regulations <ul style="list-style-type: none"> <li>• Type A type</li> <li>• ON-GRID side: 300mA</li> <li>• BACK-UP side: 30mA</li> </ul>	Self-provided	-
6	Meter Switch	<ul style="list-style-type: none"> <li>• Nominal Voltage: 380V/400V</li> <li>• Rated Current: 0.5A</li> </ul>	Self-provided	-

### 5.3.2 Preparing Cables

No.	Cable	Recommended Specifications	Acquisition Method
1	Inverter Protective Ground Cable	<ul style="list-style-type: none"> <li>• Single-core outdoor copper cable</li> <li>• Conductor cross-sectional area: 6mm<sup>2</sup>-10mm<sup>2</sup></li> </ul>	Customer-provided
2	Battery Protective Ground Cable Lynx C Series 60kWh Commercial & Industrial Battery System	<ul style="list-style-type: none"> <li>• Single-core outdoor copper cable</li> <li>• Conductor cross-sectional area: 6mm<sup>2</sup></li> </ul>	Customer-provided
	Battery Protective Ground Cable BAT-S Series 15.3-56.3kWh High Voltage Battery	<ul style="list-style-type: none"> <li>• Single-core outdoor copper cable</li> <li>• Conductor cross-sectional area: 10-16mm<sup>2</sup></li> </ul>	

No.	Cable	Recommended Specifications	Acquisition Method
	Battery Protective Ground Cable BAT-C Series 61.4-112.6kWh Commercial & Industrial Battery System	<ul style="list-style-type: none"> <li>• Single-core outdoor copper cable</li> <li>• Conductor cross-sectional area: 16-25mm<sup>2</sup></li> </ul>	
3	PV DC Cable	<ul style="list-style-type: none"> <li>• Industry-standard outdoor PV cable</li> <li>• Conductor cross-sectional area: 4mm<sup>2</sup>-6mm<sup>2</sup></li> <li>• Cable outer diameter: 5.9mm-8.8mm</li> </ul>	Customer-provided
4	Battery DC Cable	<p>Terminal Type I</p>  <ul style="list-style-type: none"> <li>• Single-core outdoor copper cable</li> <li>• Conductor cross-sectional area: 10mm<sup>2</sup></li> <li>• Cable outer diameter: 6.5mm-9.5mm</li> </ul> <hr/> <p>Terminal Type II</p>  <ul style="list-style-type: none"> <li>• Single-core outdoor copper cable</li> <li>• Conductor cross-sectional area: 10mm<sup>2</sup></li> <li>• Cable outer diameter: 5mm-8.5mm</li> </ul>	Included / Customer-provided

No.	Cable	Recommended Specifications	Acquisition Method
5	Battery Cluster Parallel Power Cable Lynx C Series 60kWh Commercial & Industrial Battery System	<ul style="list-style-type: none"> <li>• Single-core outdoor copper cable</li> <li>• Conductor cross-sectional area: 32mm<sup>2</sup>-35mm<sup>2</sup></li> <li>• Cable outer diameter: 10mm-12mm</li> </ul>	Customer-provided
	Battery Cluster Parallel Power Cable BAT-S Series 15.3-56.3kWh High Voltage Battery	<ul style="list-style-type: none"> <li>• Single-core outdoor copper cable</li> <li>• Conductor cross-sectional area: 25mm<sup>2</sup></li> <li>• Cable outer diameter: 9mm-11mm</li> </ul>	Customer-provided
6	AC Cable	<ul style="list-style-type: none"> <li>• Multi-core outdoor copper cable</li> <li>• Conductor cross-sectional area: 10mm<sup>2</sup>-16mm<sup>2</sup></li> <li>• Cable outer diameter: 21mm-26mm</li> </ul>	Customer-provided
7	Smart Meter Power Cable	Outdoor copper cable Conductor cross-sectional area: 1mm <sup>2</sup>	Customer-provided
8	Battery BMS Communication cable	-	Included
9	Meter RS485 Communication cable	-	RJ45-2PIN terminal adapter cable and standard Ethernet cable, included
10	Battery Cluster Parallel Communication cable	CAT 5E or above standard Ethernet cable and RJ45 connector	Customer-provided

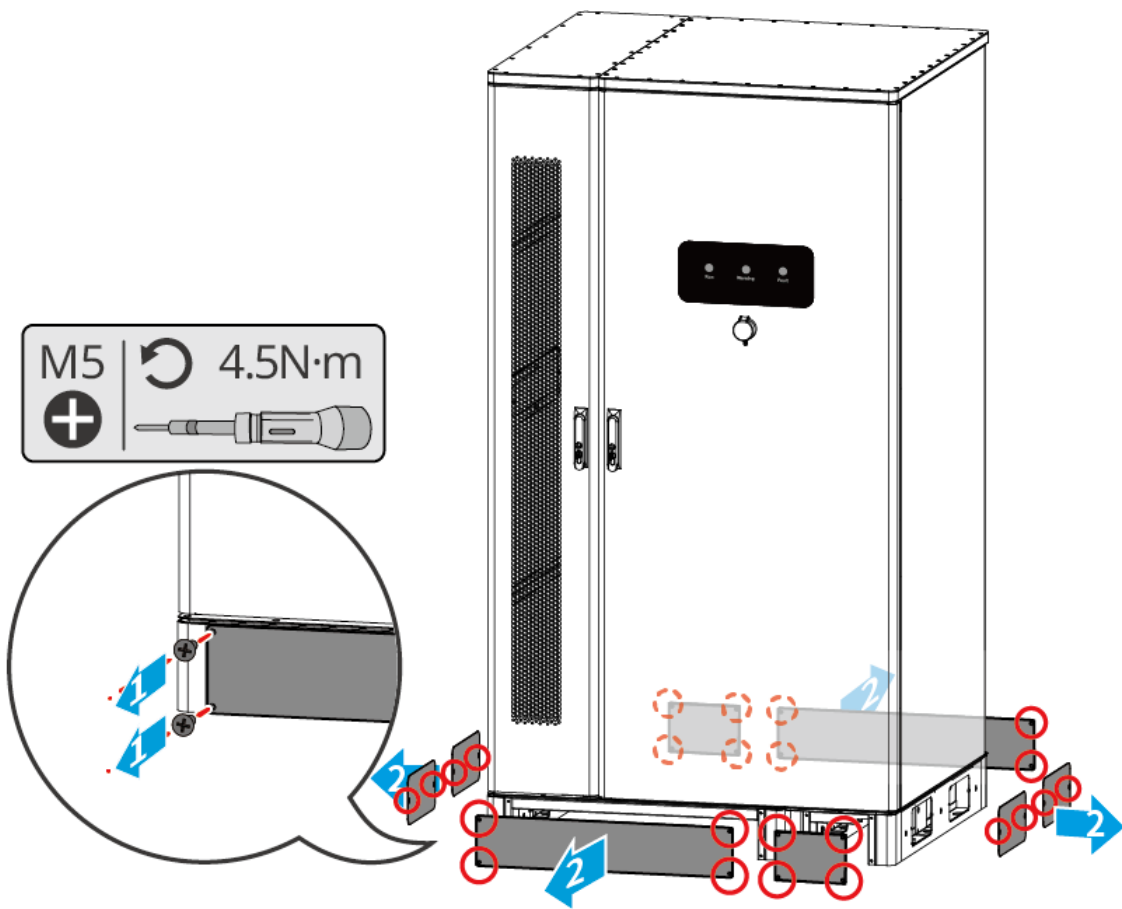
No.	Cable	Recommended Specifications	Acquisition Method
11	load control DO Communication cable	<ul style="list-style-type: none"> <li>Shielded cable meeting local standards</li> <li>Conductor cross-sectional area: 0.2mm<sup>2</sup>-0.3mm<sup>2</sup></li> <li>Cable outer diameter: 5mm-8mm</li> </ul>	Customer-provided
12	Remote Shutdown Communication cable		Customer-provided
13	RCR/DRED Signal Cable		Customer-provided
14	Inverter Parallel Communication Cable	CAT 5E or above standard Ethernet cable and RJ45 connector	Customer-provided
15	EMS Communication cable/Charging Pile Communication cable	CAT 5E or above standard Ethernet cable and RJ45 connector	Customer-provided
16	12V External Power Supply	<ul style="list-style-type: none"> <li>Outdoor copper cable</li> <li>Conductor cross-sectional area: 0.2mm<sup>2</sup>-0.3mm<sup>2</sup></li> <li>Cable outer diameter: 5mm-8mm</li> </ul>	Customer-provided
17	Air Conditioner Power Cable Lynx C Series 60kWh Commercial & Industrial Battery System	-	Pre-installed
	Air Conditioner Power Cable BAT-C Series 61.4-112.6kWh Commercial & Industrial Battery System	-	Included

### 5.3.3 Removing the Cover

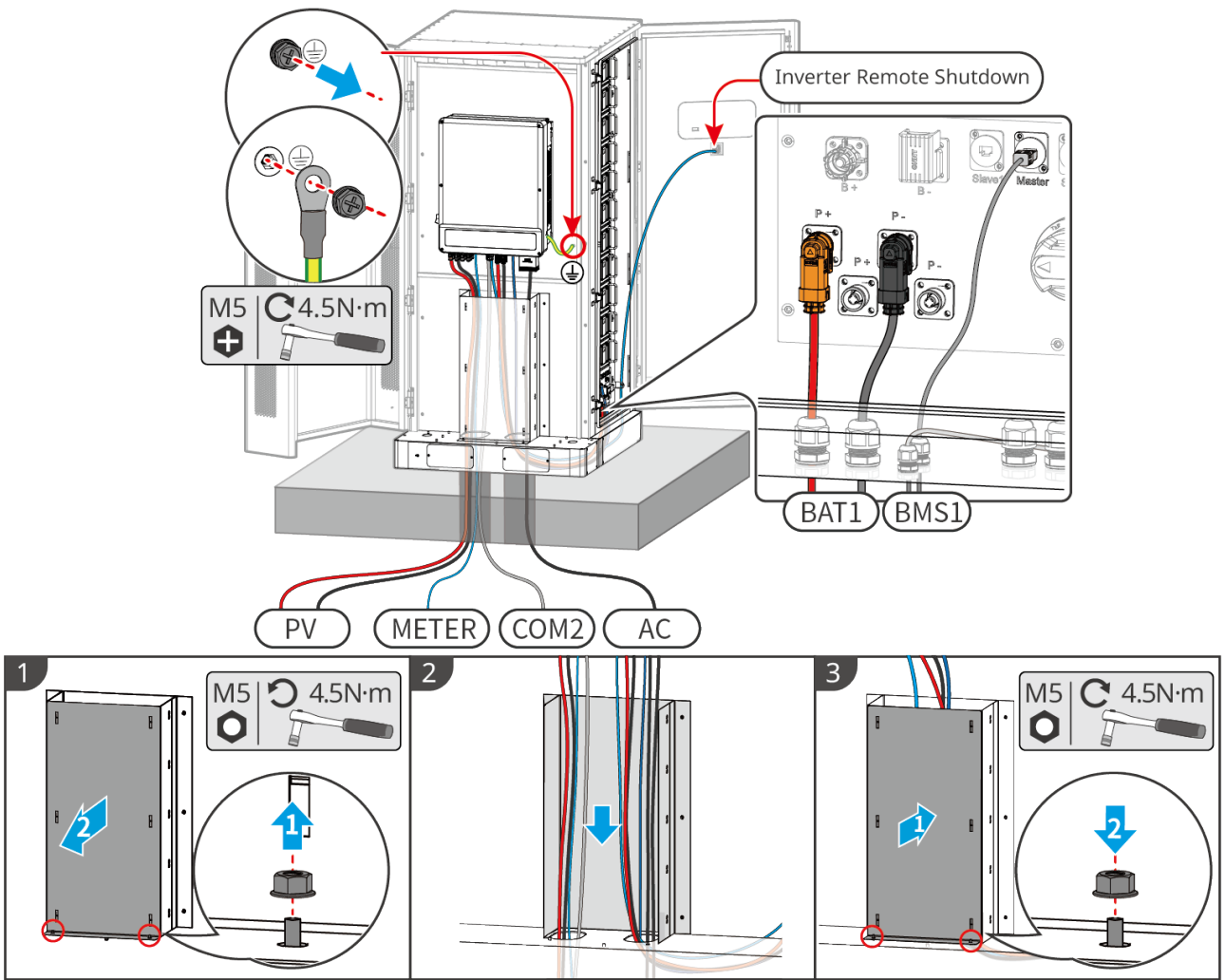
#### WARNING

- After completing system installation and before starting wiring, remove the baffle.
- After completing system wiring, install the baffle to the enclosure.

Remove the bottom cover



Inverter wiring area cover



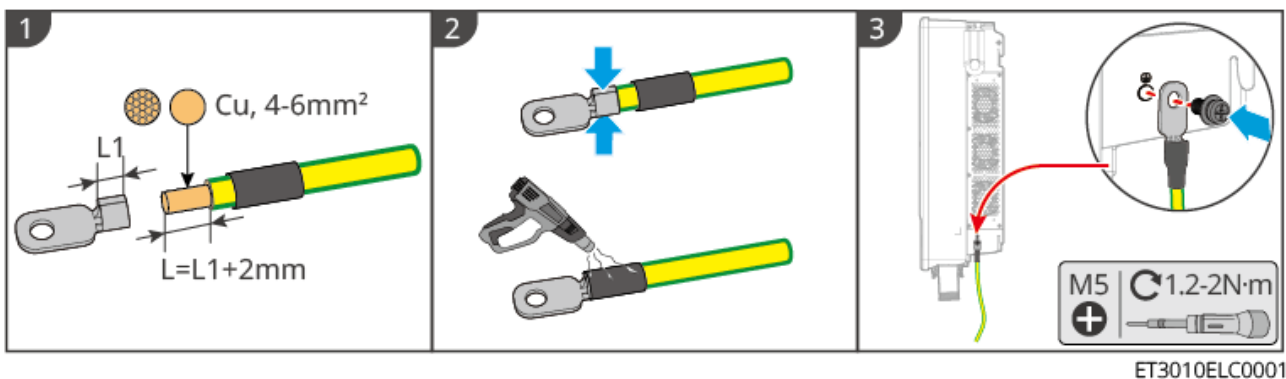
LXC6010ELC0004

## 5.4 Connecting the PE cable

## !WARNING

- The protective grounding of the chassis cannot replace the protective ground wire of the AC output port. When wiring, ensure the protective ground wires at both locations are reliably connected.
- To improve the corrosion resistance of the terminal, it is recommended to apply silicone or paint on the exterior of the grounding terminal for protection after the protective ground wire installation is complete.
- When installing the equipment, the protective ground wire must be installed first; when removing the equipment, the protective ground wire must be removed last.

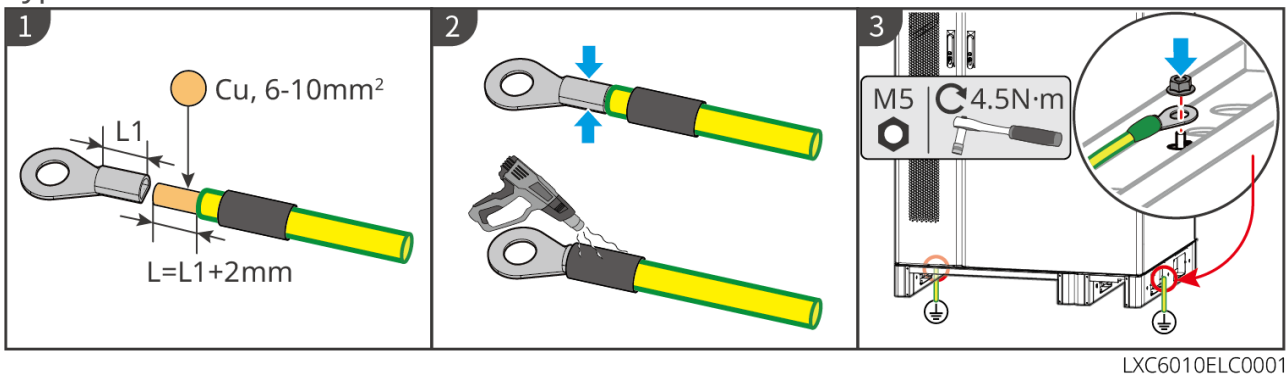
### 5.4.1 Inverter Grounding



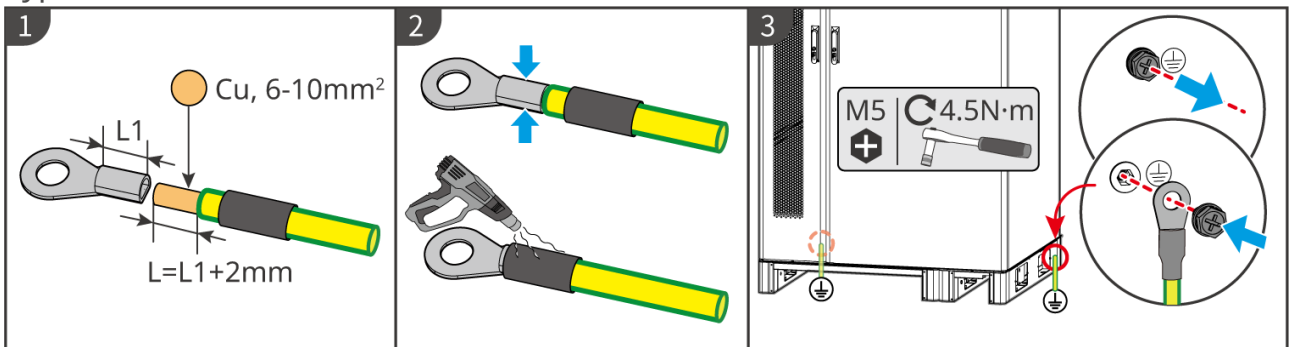
### 5.4.2 Battery System Grounding

- Lynx C series 60kWh industrial and commercial battery system

Type one

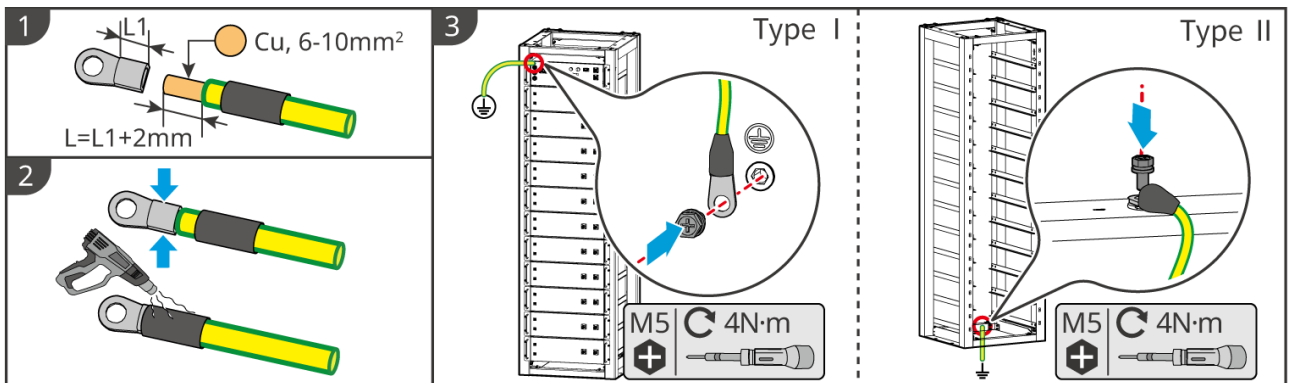


### Type two



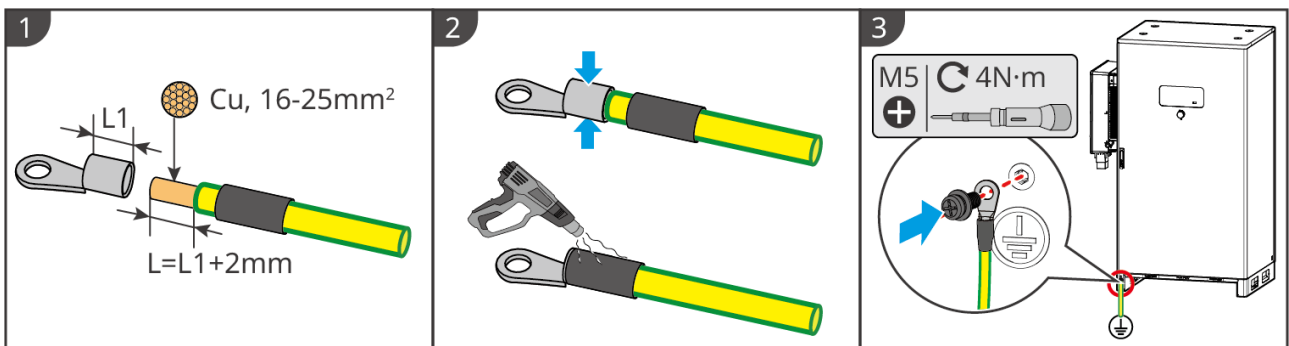
LXC6010ELC0007

### • BAT-Sseries 15.3-56.3kWh high voltage Battery



BAT10ELC0001

### • BAT-Cseries 61.4-112.6kWh industrial and commercial battery system



BAT10ELC0007

## 5.5 Connecting the PV Cable

## DANGER

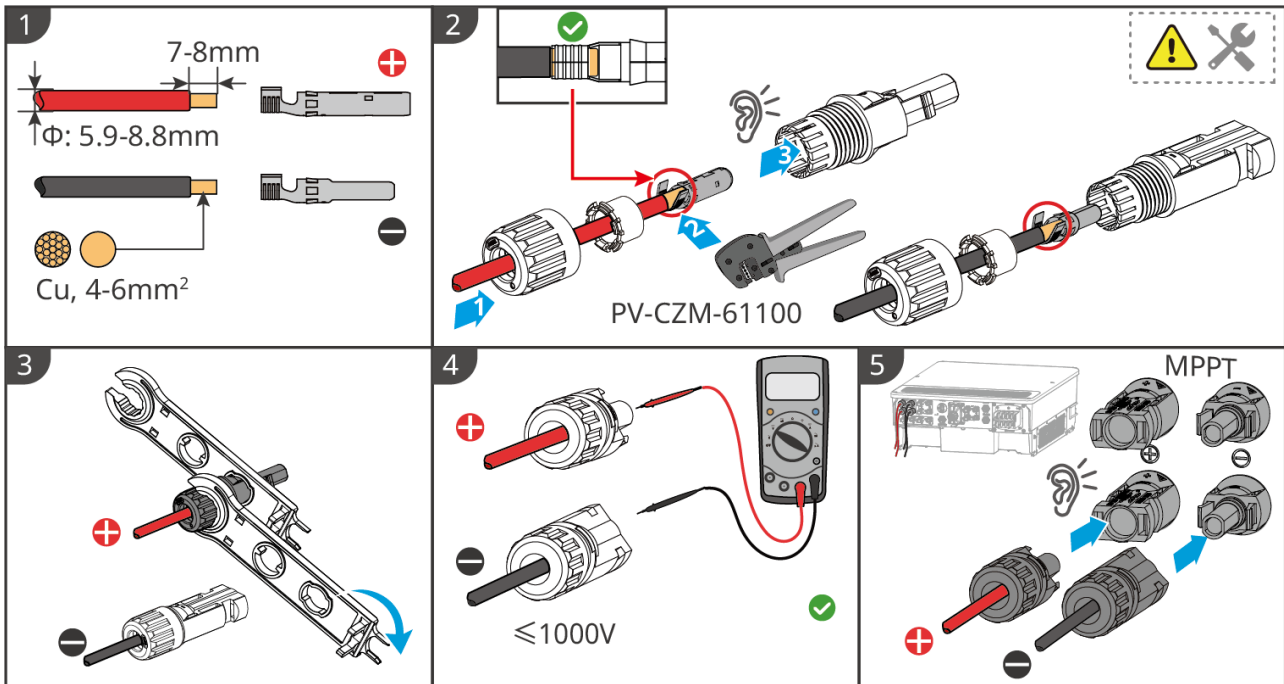
- Do not connect the same PV string to multiple inverters, as this may cause inverter damage.
- Before connecting the PV string to the inverter, confirm the following information. Failure to do so may cause permanent inverter damage and, in severe cases, may lead to fire resulting in personal injury and property loss.
  1. Ensure the maximum short-circuit current and maximum input voltage for each MPPT are within the inverter's allowable range.
  2. Ensure the positive terminal of the PV string is connected to the inverter's PV+, and the negative terminal is connected to the inverter's PV-.

## WARNING

- The PV string output does NOT support grounding. Before connecting the PV string to the inverter, ensure the minimum insulation resistance to ground of the PV string meets the minimum insulation resistance requirement ( $R = \text{Max. Input Voltage} / 30\text{mA}$ ).
- After connecting the DC cables, ensure the connections are tight and secure, with no looseness.
- Use a multimeter to measure the DC cable positive and negative poles, ensuring correct polarity (no reverse connection) and that the voltage is within the allowable range.

## NOTICE

The two sets of photovoltaic strings within each MPPT circuit must use the same model, the same number of panels, and identical tilt and azimuth angles to ensure maximum efficiency.



ET3010ELC0030

## 5.6 Connecting Battery System Cables

### DANGER

- Do not connect the same battery pack to multiple inverters, as this may cause inverter damage.
- It is prohibited to connect loads between the inverter and the battery.
- When connecting battery cables, use insulated tools to prevent accidental electric shock or battery short circuit.
- Ensure that the battery open-circuit voltage is within the allowable range of the inverter.
- Before connecting battery cables, confirm that the battery module and high-voltage box are powered off, and the battery cluster switch and DC power supply switch are disconnected.
- Between the inverter and the battery, choose whether to configure a DC switch according to local laws and regulations.

## WARNING

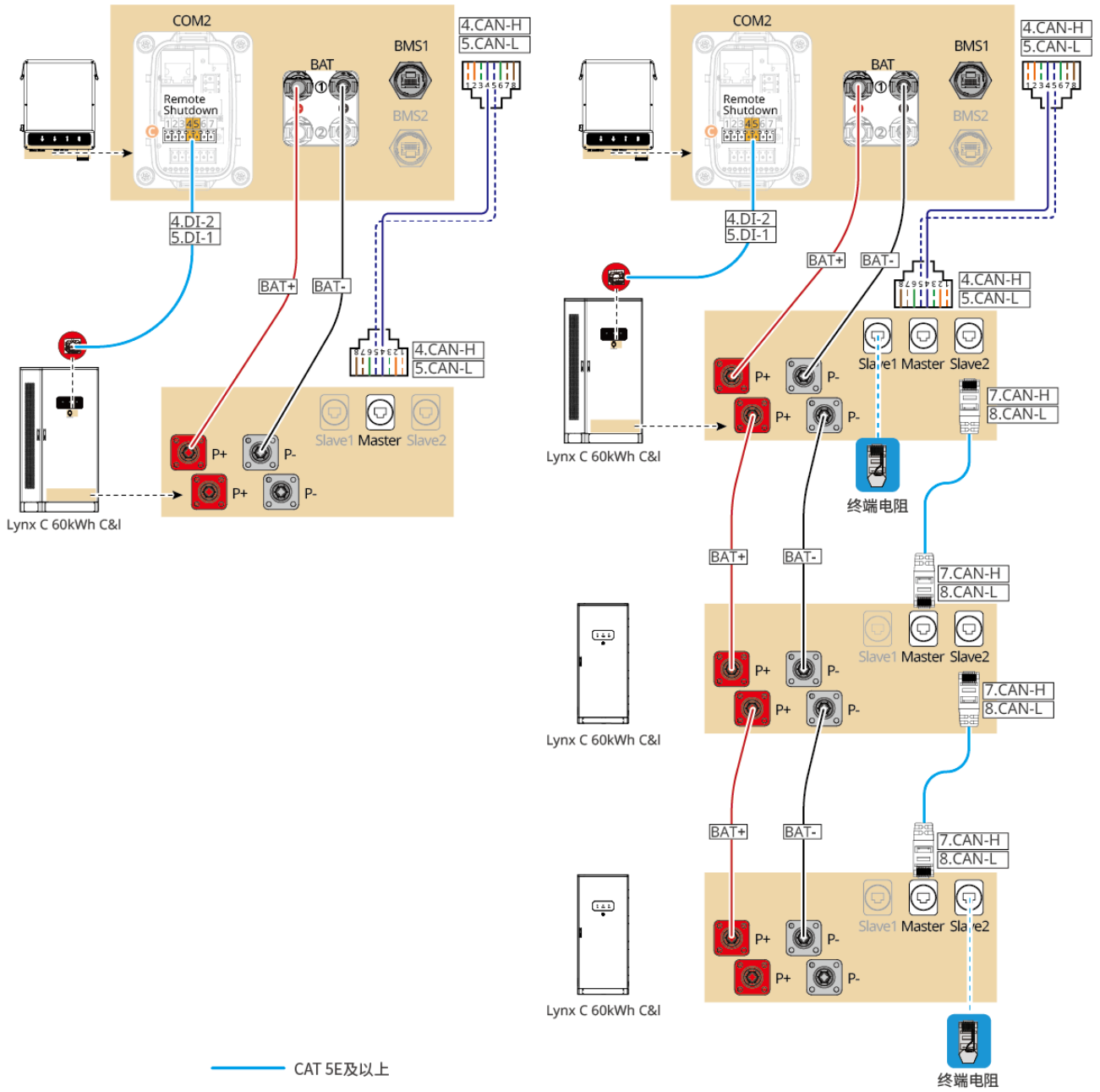
- Use a multimeter to measure the positive and negative poles of the DC cable to ensure correct polarity, with no reverse connection, and that the voltage is within the allowable range.
- During wiring, ensure the battery cables match the "BAT+", "BAT-", and ground terminals on the battery end exactly. Incorrect cable connection will cause equipment damage.
- Ensure the wire core is fully inserted into the terminal connection port with no exposed part.
- Ensure the cable connections are tight; otherwise, loose connections may cause terminal overheating and equipment damage during operation.
- Do not connect the same battery bank to multiple inverters, as this may cause inverter damage.

## NOTICE

When a 25-30kW inverter is used in conjunction with the BAT series 61.4kWh commercial & industrial battery system, two BAT ports must be connected to achieve full load operation.

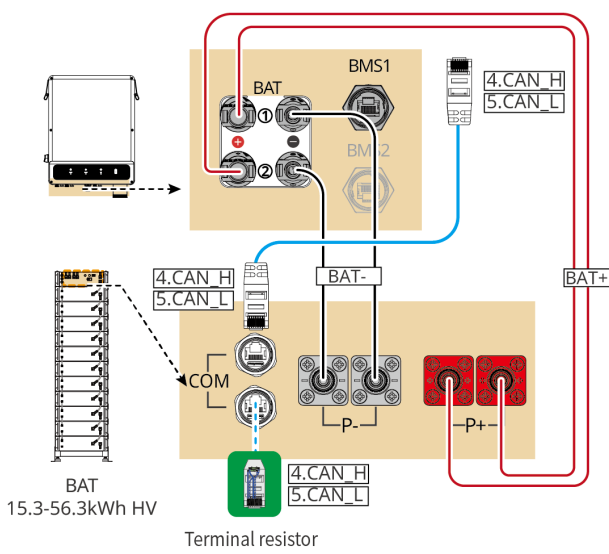
### Battery System Wiring Diagram

- Lynx C Series 60kWh Commercial & Industrial Battery System

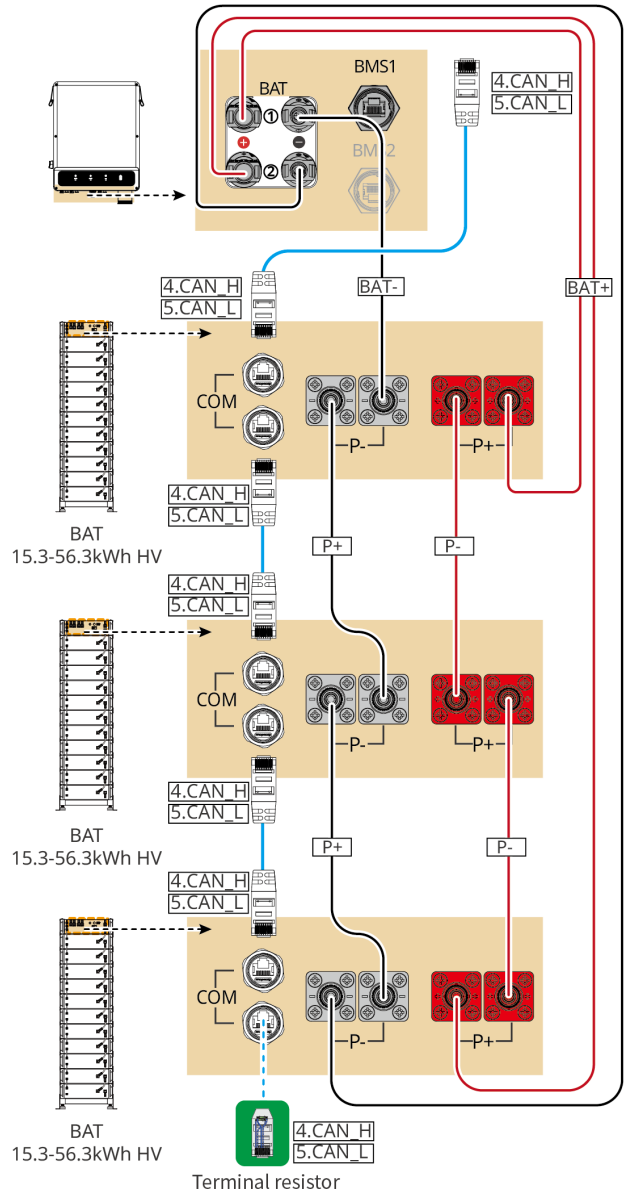


ET3010NET0026

- BAT-S Series 15.3-56.3kWh High Voltage Battery

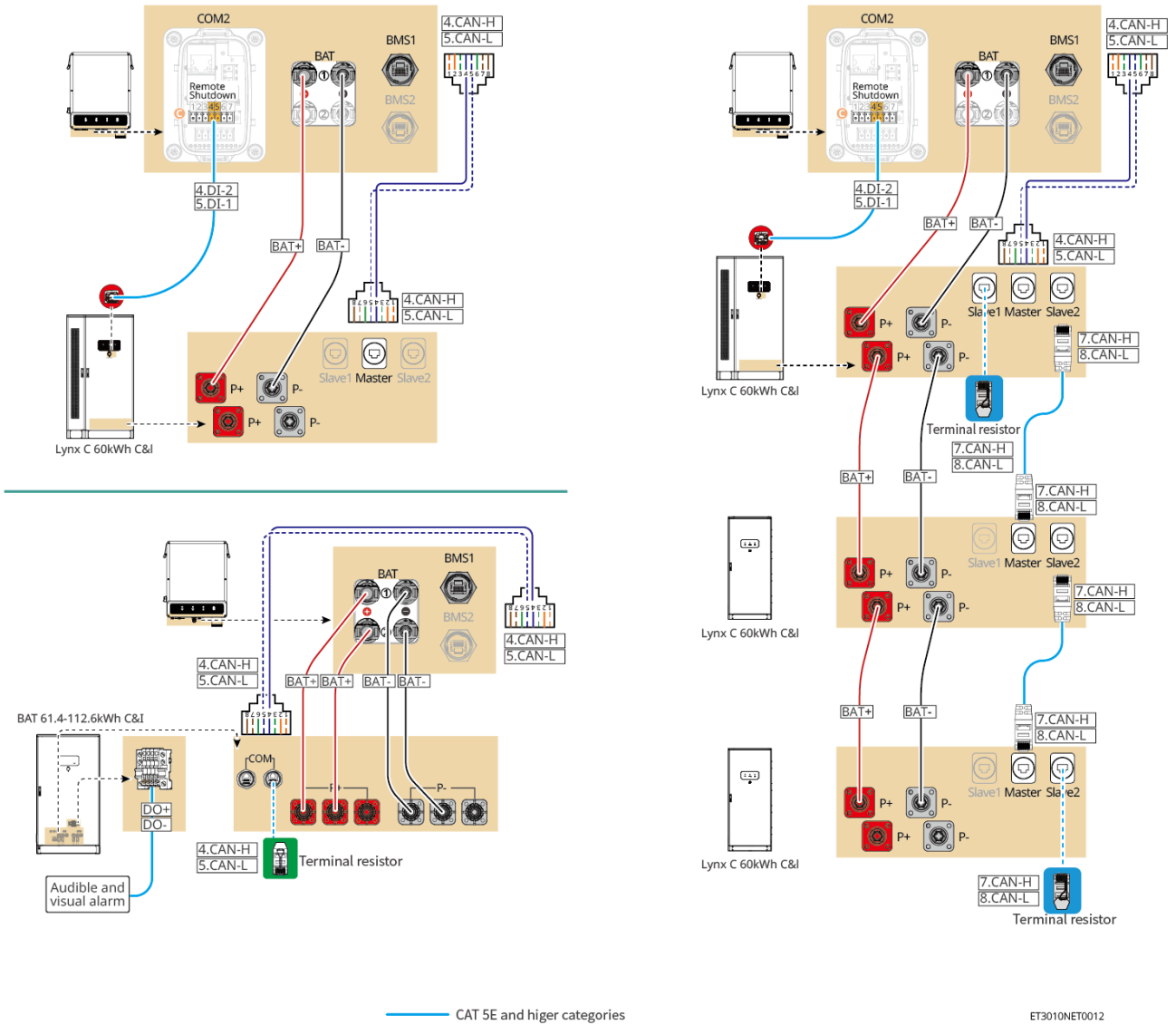


— CAT 5E and higher categories



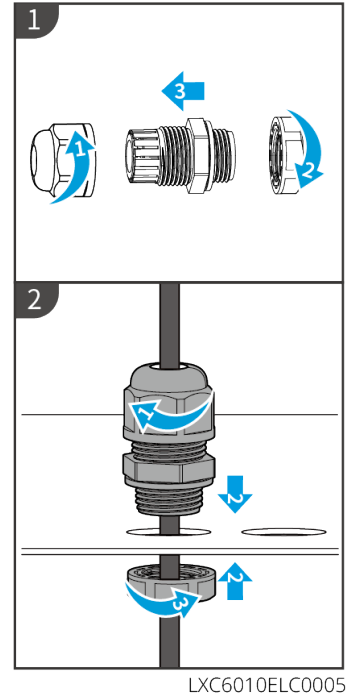
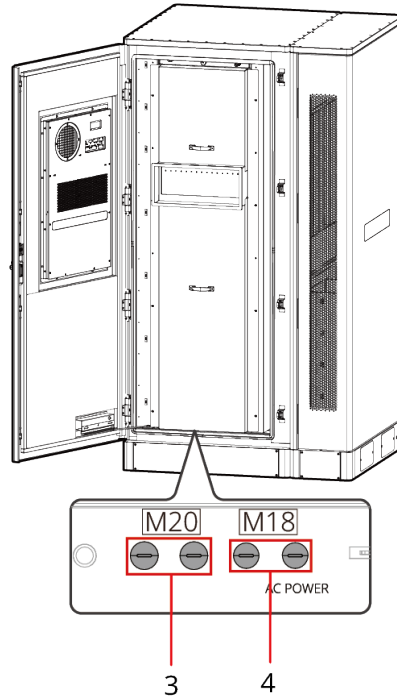
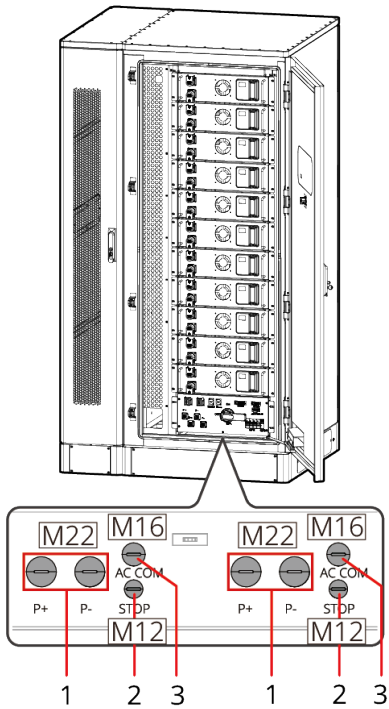
ET3010NET0027

- BAT-C Series 61.4-112.6kWh Commercial & Industrial Battery System



## 5.6.1 Paired with Lynx C Series 60kWh Commercial & Industrial Battery System

### 5.6.1.1 Battery Wire Feed-through Introduction



No.	Description	No.	Description
1	Battery power cable routing hole	2	Emergency stop button control cable routing hole
3	Communication cable routing hole	4	Air conditioning cable routing hole
5	Reserved cable routing hole	-	-

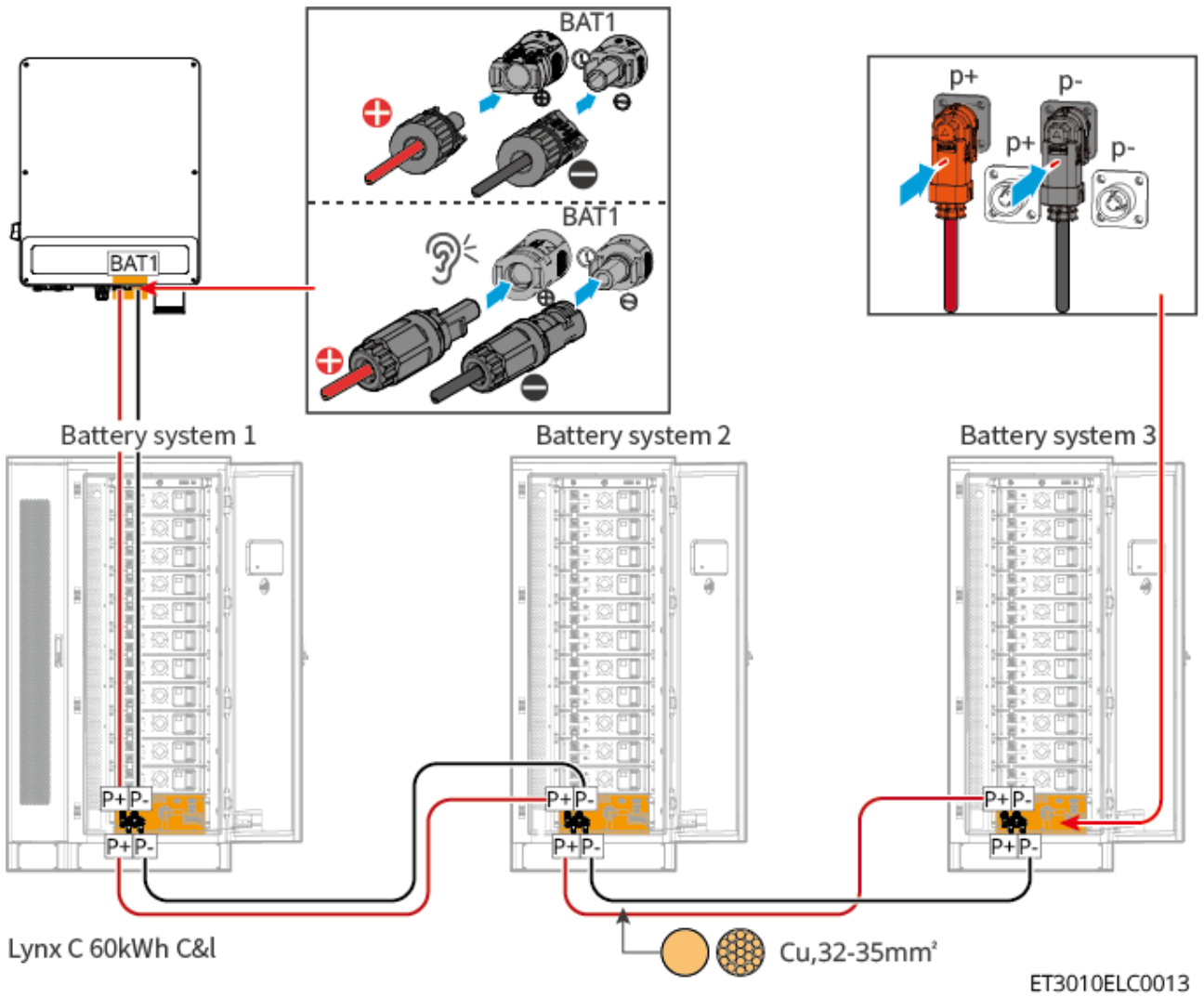
### 5.6.1.2 Connecting the Power Cable between the Inverter and Battery

## WARNING

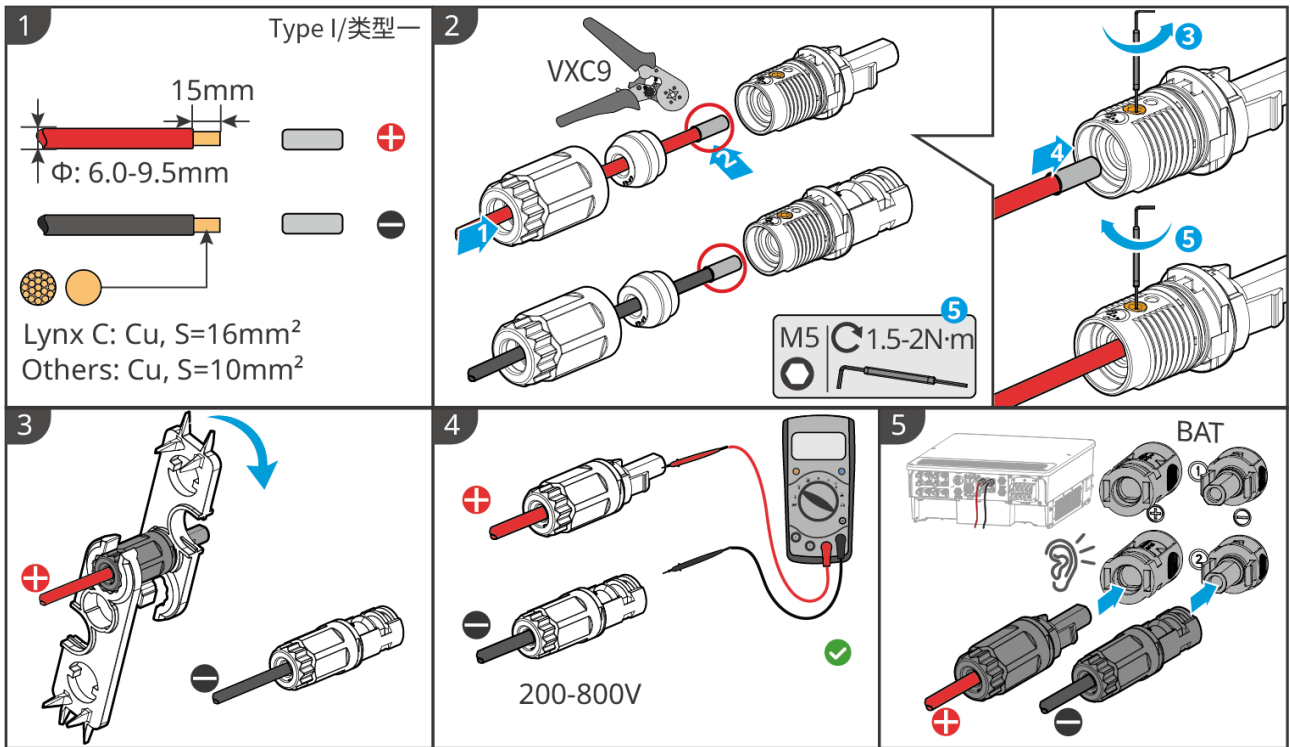
- Use a multimeter to measure the positive and negative poles of the DC cable to ensure correct polarity without reverse connection; and the voltage is within the allowable range.
- During wiring, ensure that the battery wires completely match the battery terminals "BAT+", "BAT-", and ground port. If the cable connection is incorrect, it will cause equipment damage.
- Ensure that the wire core is fully inserted into the terminal wiring hole without exposure.
- Ensure that the cable connections are tight; otherwise, during equipment operation, it may cause terminal overheating and equipment damage.
- Do not connect the same battery bank to multiple inverters; otherwise, it may cause inverter damage.

## NOTICE

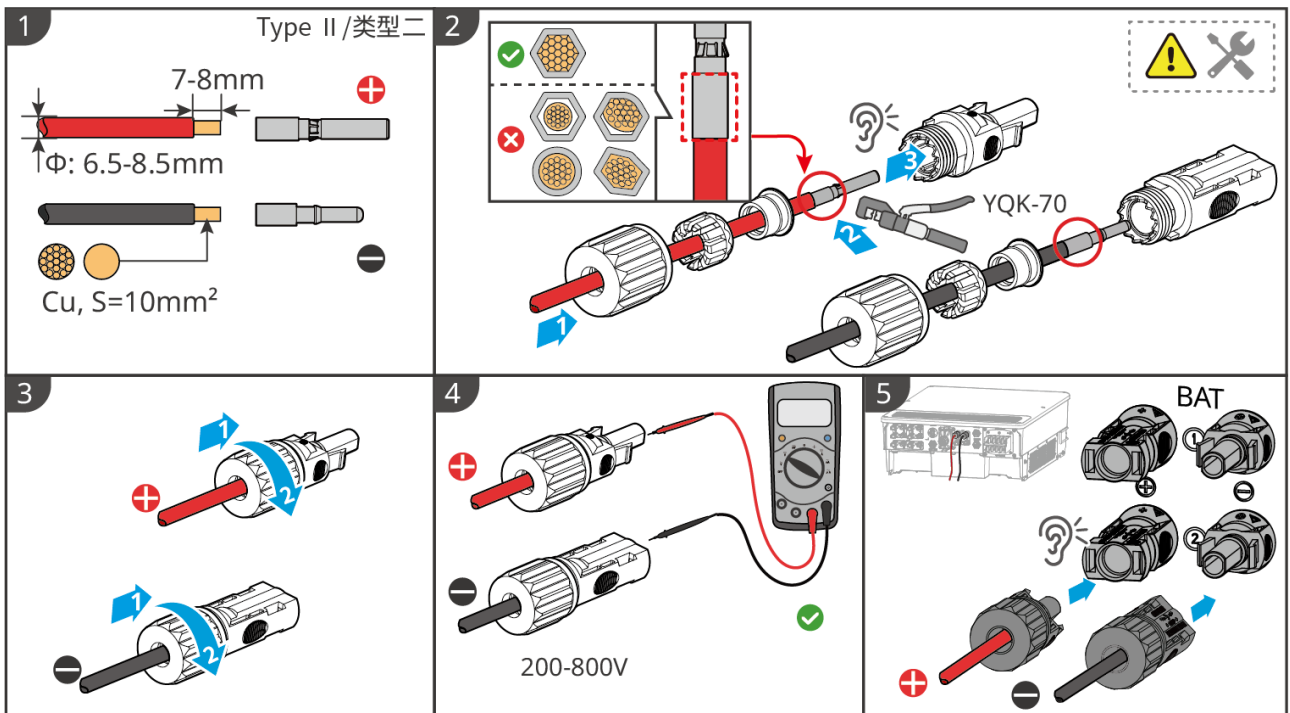
- The battery system comes with a power cable for connecting to the inverter.
  - If a Type I terminal is included in the inverter accessories, cut off the terminal on the battery system's power cable that connects to the inverter, and use the battery connector provided with the inverter to remake the power cable.
  - If a Type II terminal is included in the inverter accessories, you can directly use the power cable from the battery system accessories.
  - If the power cable in the battery system accessories does not have a terminal for connecting to the inverter, use the connector from the inverter accessories to make the power cable.
- The power cables for parallel clustering between battery systems need to be self-provided.
- Please connect the battery system to the inverter's BAT1 port.



**Inverter End Cable Assembly Method**

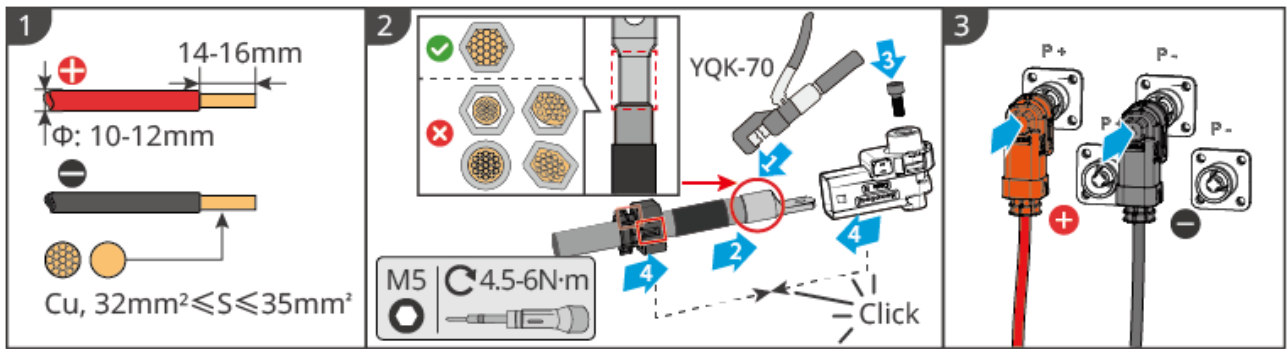


ET3010ELC0031



ET3010ELC0032

### Battery System Cluster Power Cable Assembly Method



LXC6010ELC0002

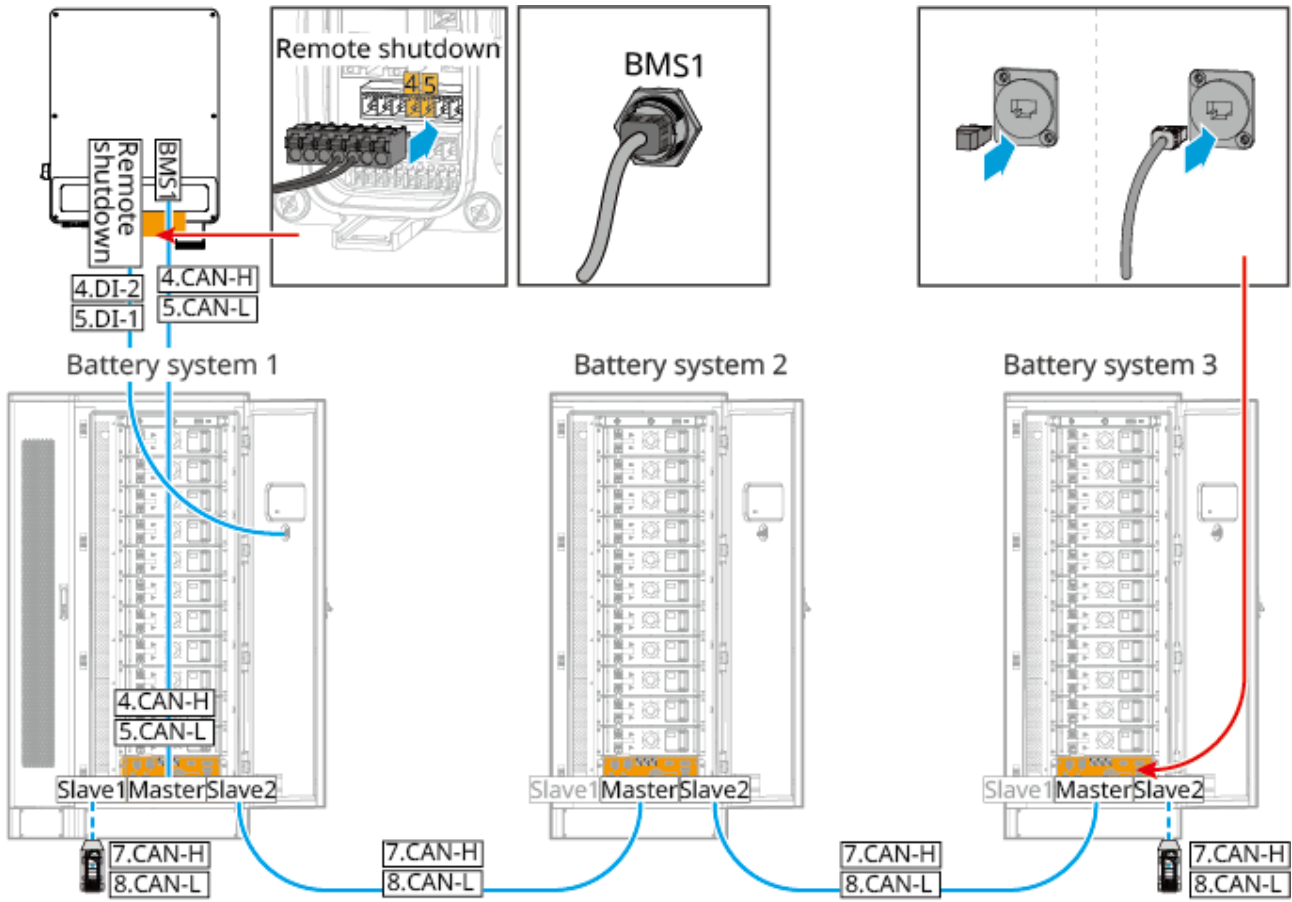
### 5.6.1.3 Battery Communication Cable Connection

#### ⚠ WARNING

Do not omit the installation of the battery system terminal resistor, otherwise it will cause communication failure between battery systems.

#### NOTICE

- The battery system is shipped with a BMS battery communication cable. It is recommended to use the provided cable. If the supplied cable does not meet the requirements, please prepare your own shielded network cable and shielded RJ45 connector.
- Please connect the battery system to the BMS1 communication port of the inverter; otherwise, normal communication may not be possible.
- The emergency stop switch communication cable is pre-installed on the enclosure. If the supplied cable does not meet the requirements, please prepare your own communication cable.
- For inter-cluster communication cables between battery systems, please prepare shielded network cables and shielded RJ45 connectors that meet the EIA/TIA-568B standard.
- PIN4 and PIN5 are for inverter communication only. When making inter-cluster communication cables for battery systems, do not crimp PIN4 and PIN5.
- When connecting battery systems in a cluster, connect the inverter remote shutdown port to the main battery system.



Lynx C 60kWh C&I

ET3010ELC0014

**Explanation of BMS Communication Connection between Inverter and Battery:**

Device	Port	Definition	Description
Inverter	BMS1	4: CAN_H 5: CAN_L	CAN communication between the Inverter and the Battery
	Remote Shutdown	7: GND 8: Remote Shutdown	Connected to the battery system to control the emergency shutdown of the battery
Battery	Slave1	7: CAN_H 8: CAN_L	Parallel cluster CAN communication between batteries
	Master	1: RS485_A1 2: RS485_B1	Reserved for communication with the inverter

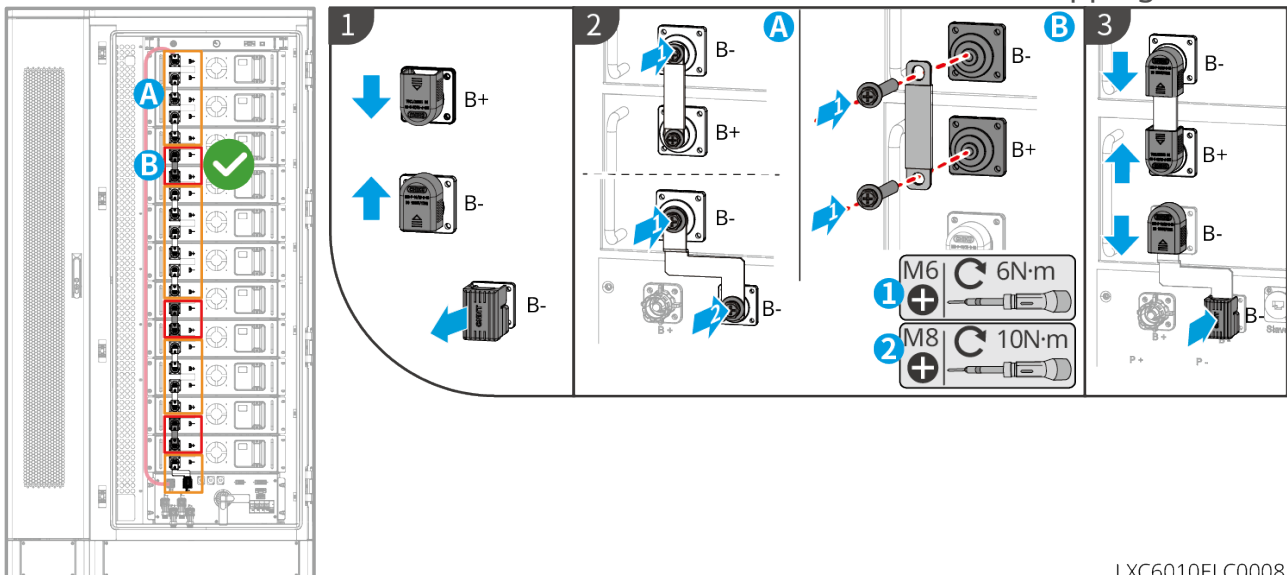
Device	Port	Definition	Description
		4: CAN_H 5: CAN_L	Communication with the inverter
		7: CAN_H 8: CAN_L	Parallel cluster CAN communication between batteries
	Slave2	7: CAN_H 8: CAN_L	Parallel cluster CAN communication between batteries
	Emergency Stop Switch	1: NC 2: COM	Connected to the inverter to control the emergency shutdown of the battery

### 5.6.1.4 Connecting Internal Power Busbars of the Battery System

#### NOTICE

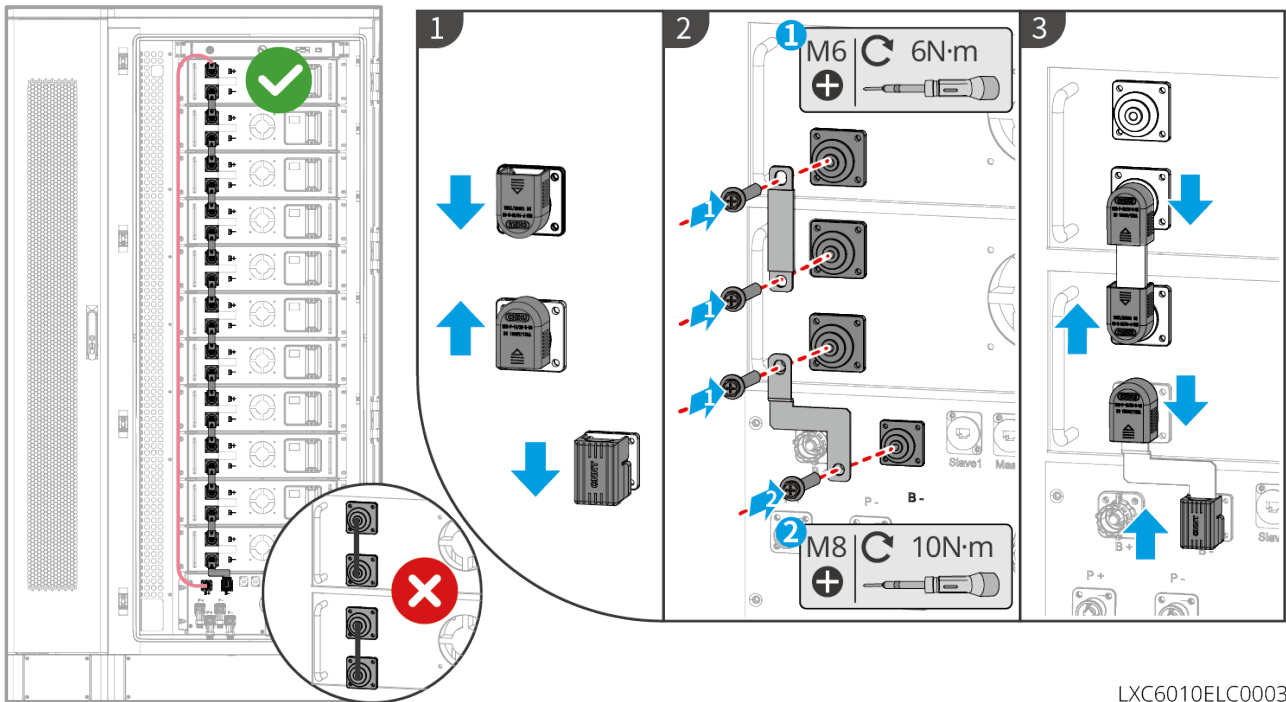
If the aluminum busbars of the battery system are pre-installed at the factory, please use tools to recheck the torque.

Scenario: Aluminum busbars between batteries are installed before shipping:



LXC6010ELC0008

Scenario: Aluminum busbars between batteries are not installed before shipping:

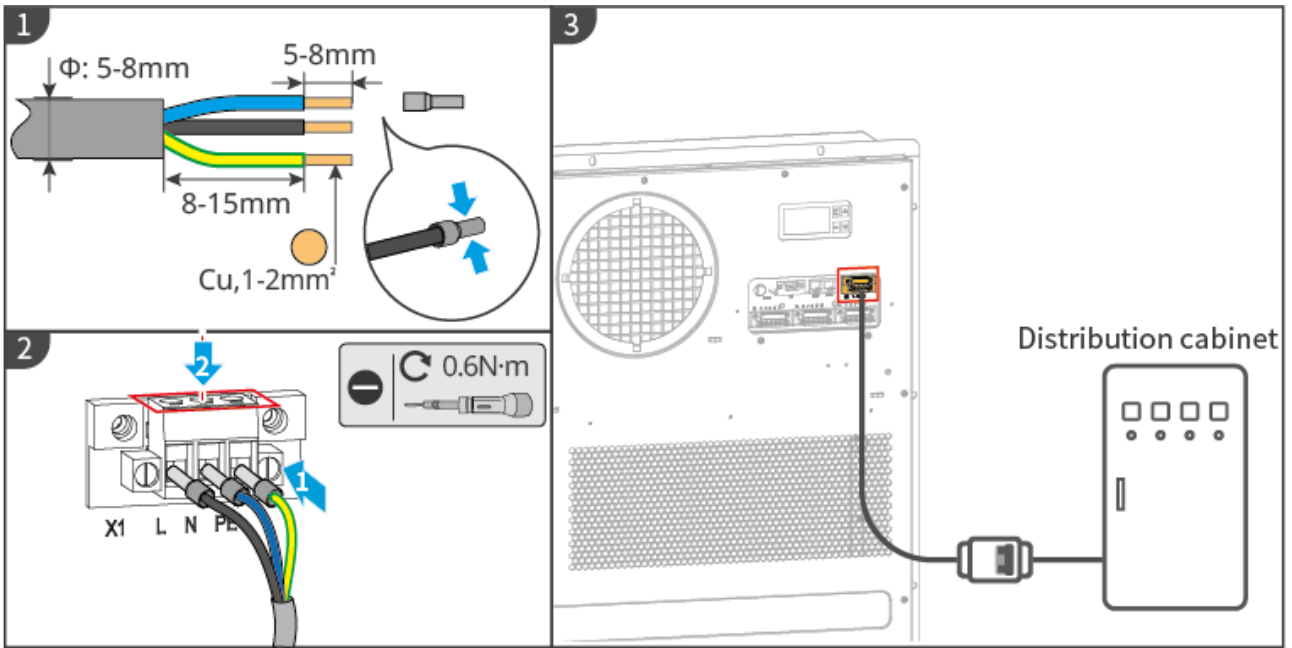


LXC6010ELC0003

### 5.6.1.5 Connect the Air Conditioning Power Cable for the Battery System

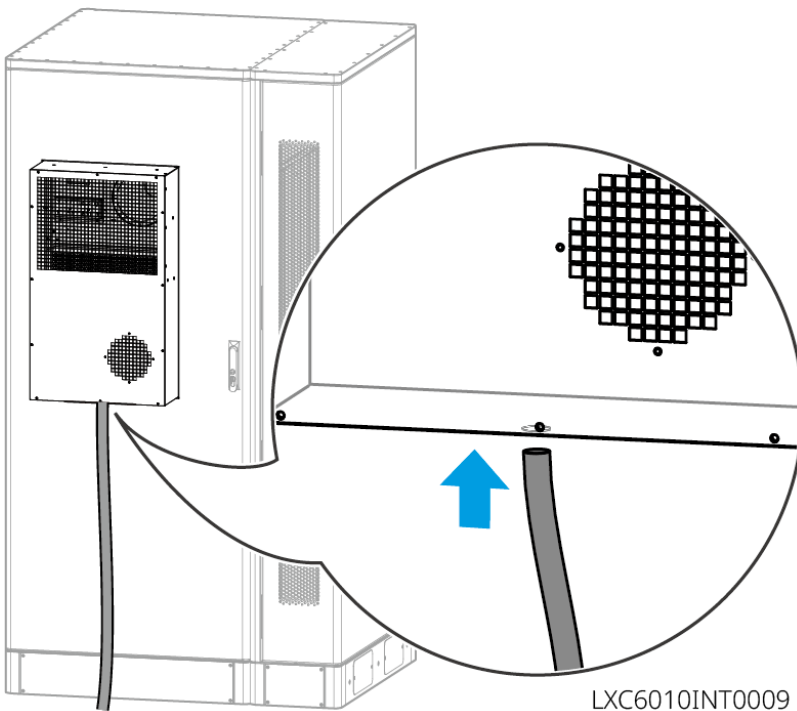
#### NOTICE

- The air conditioner power cord is pre-installed on the unit. If the supplied power cord does not meet your requirements, please prepare an extension cable yourself.
- It is recommended to connect the air conditioner power cord to the distribution cabinet for power supply.
- If emergency power supply is required for the air conditioner, you can connect its power cord to the BACK UP side of the inverter.
- To ensure the air conditioner can be safely disconnected from the distribution cabinet in case of an abnormality, please install an AC switch between the air conditioner and the distribution cabinet. The AC switch specification should be no less than 16A.
- To ensure optimal heat dissipation performance, do not arbitrarily modify the default temperature parameter settings of the air conditioner.



LXC6010ELC0006

### 5.6.1.6 Connecting Battery System Air Conditioning Drain Pipe



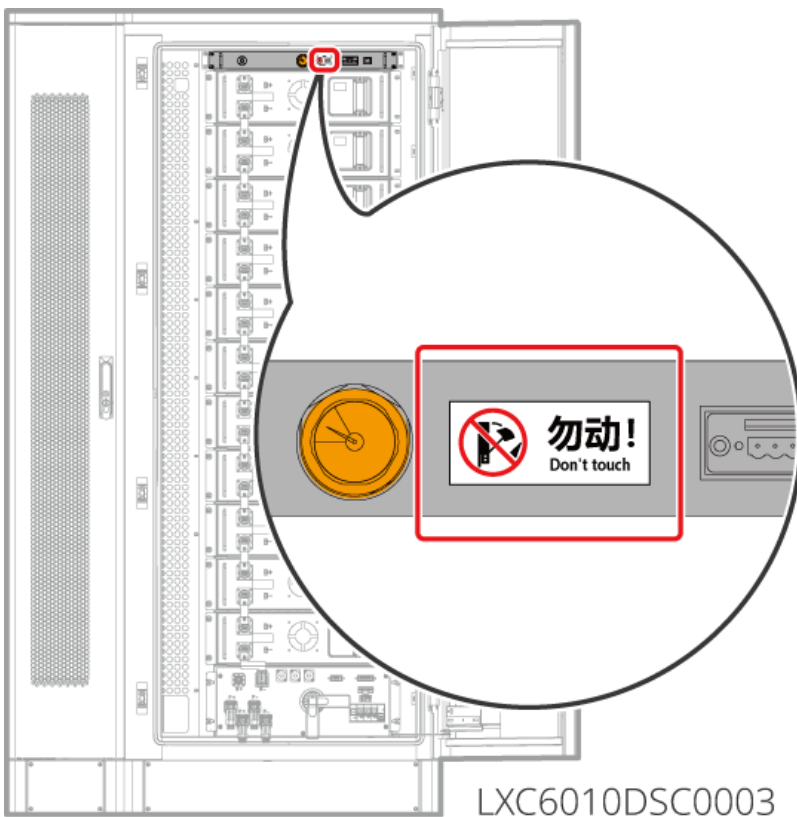
### 5.6.1.7 Open the Fire Protection Switch

## NOTICE

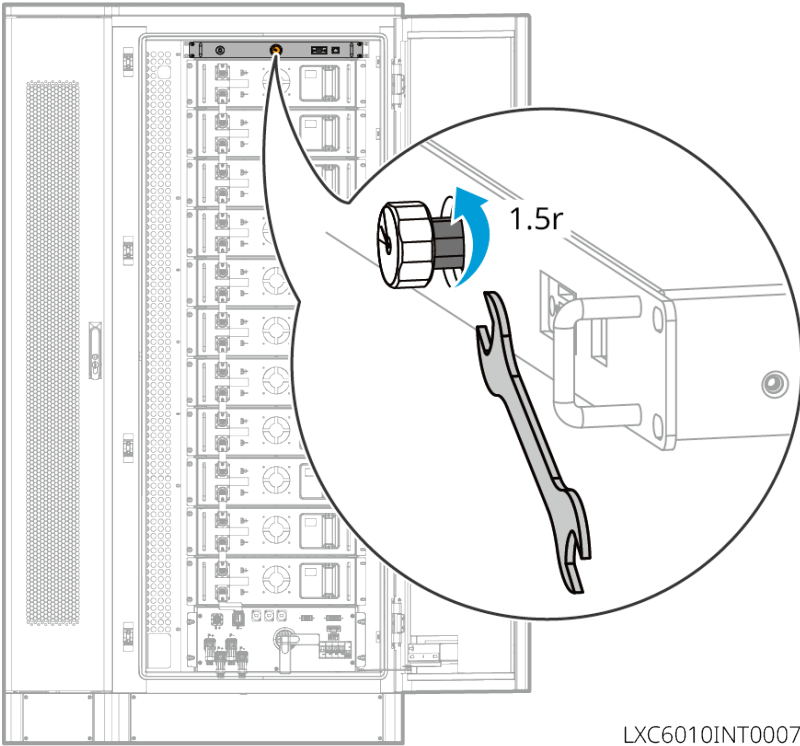
The "open" and "close" functions of the firefighting equipment are only to be enabled during professional maintenance or replacement work on the temperature-sensitive activation component.

Fire Equipment Switch Operation Scenario:

- If a "Do Not Operate" tag is present, no action is required.



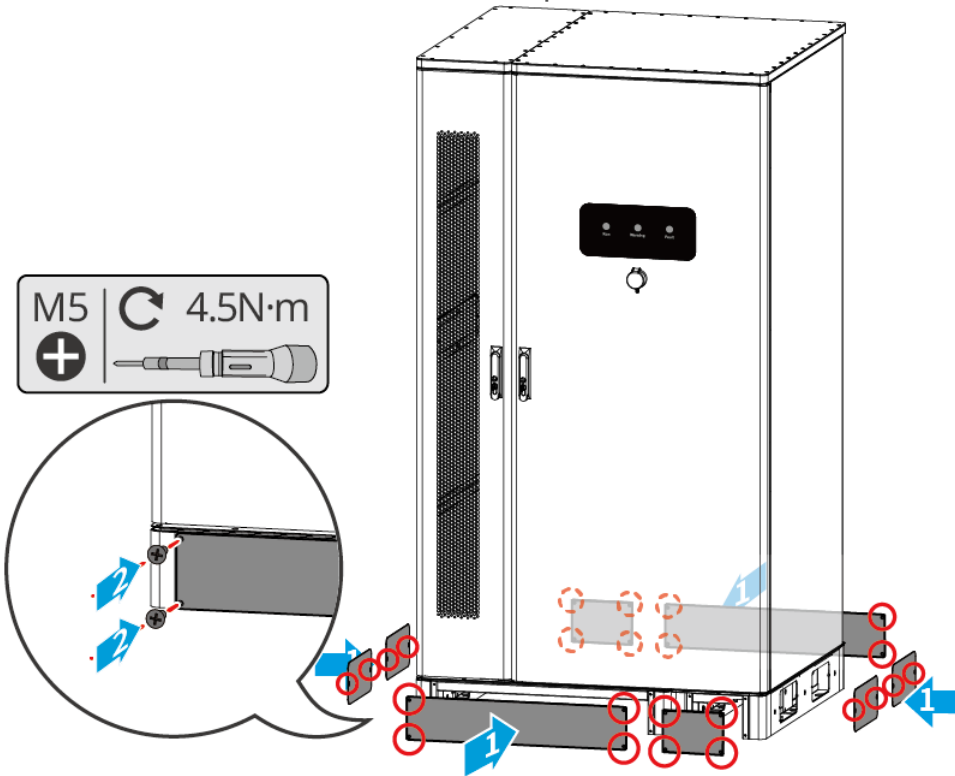
- If no tag is present, please refer to the following steps to open the fire protection switch. Using a 14mm wrench, rotate the bolt behind the pressure gauge approximately 1.5 turns counterclockwise until fully tightened. The fire protection system will then be successfully activated.



LXC6010INT0007

### 5.6.1.8 Installation Baffle

After the cable connections are complete, install the bottom baffle.



LXC6010INT0008

## 5.6.2 Paired with BAT-S Series 15.3-56.3kWh High Voltage Battery

Inverter	GW12KL -ET	GW18KL -ET	GW15K -ET	GW20 K-ET	GW25 K-ET	GW29.9K -ET	GW30K -ET
Number of BAT Ports	1	2	1	1	2	2	2
Minimum Number of PACKs Required to Match BAT-S Series Battery (Operational)	3PACK	3PACK	5PACK	5PACK	5PACK	5PACK	5PACK
Minimum Number of PACKs Required to Match BAT-S Series Battery (Full Load)	5PACK	4PACK	6PACK	8PACK	5PACK	6PACK	6PACK

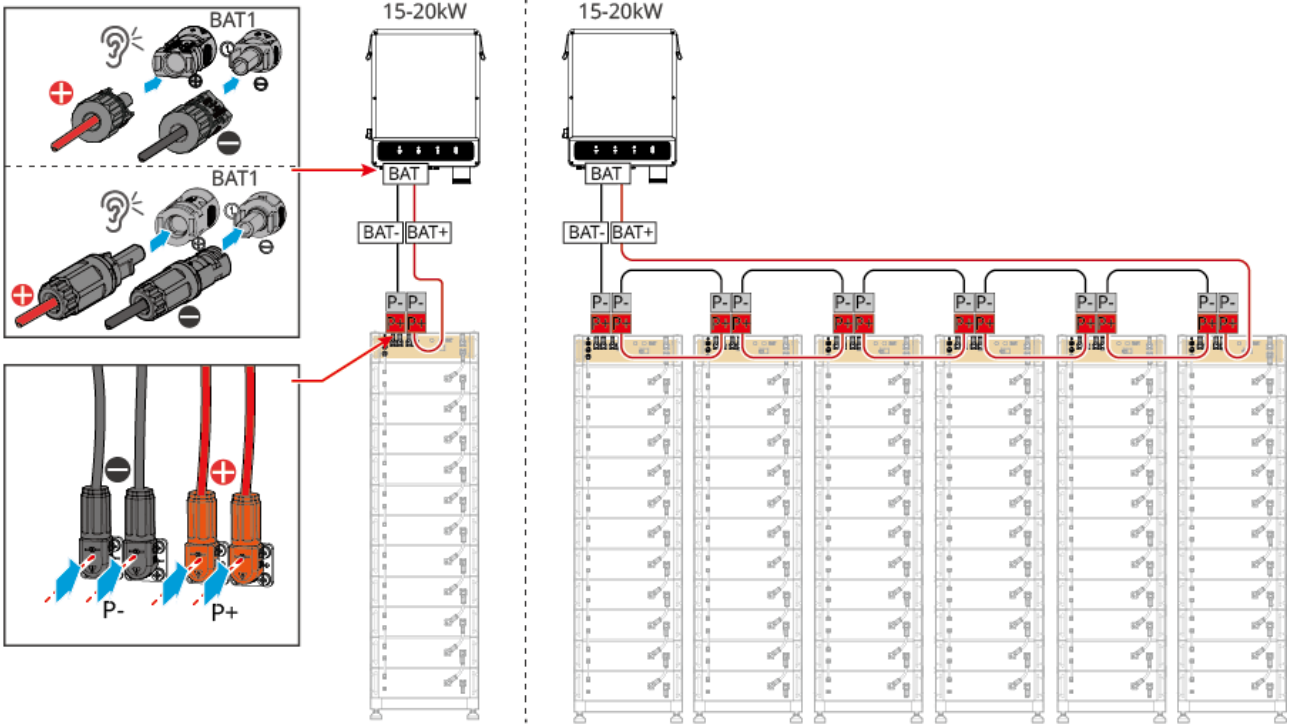
### 5.6.2.1 Connecting the Power Cable between the Inverter and Battery

#### NOTICE

The BAT-S Series 15.3-56.3kWh high-voltage battery supports up to 6 battery cabinets connected in parallel.

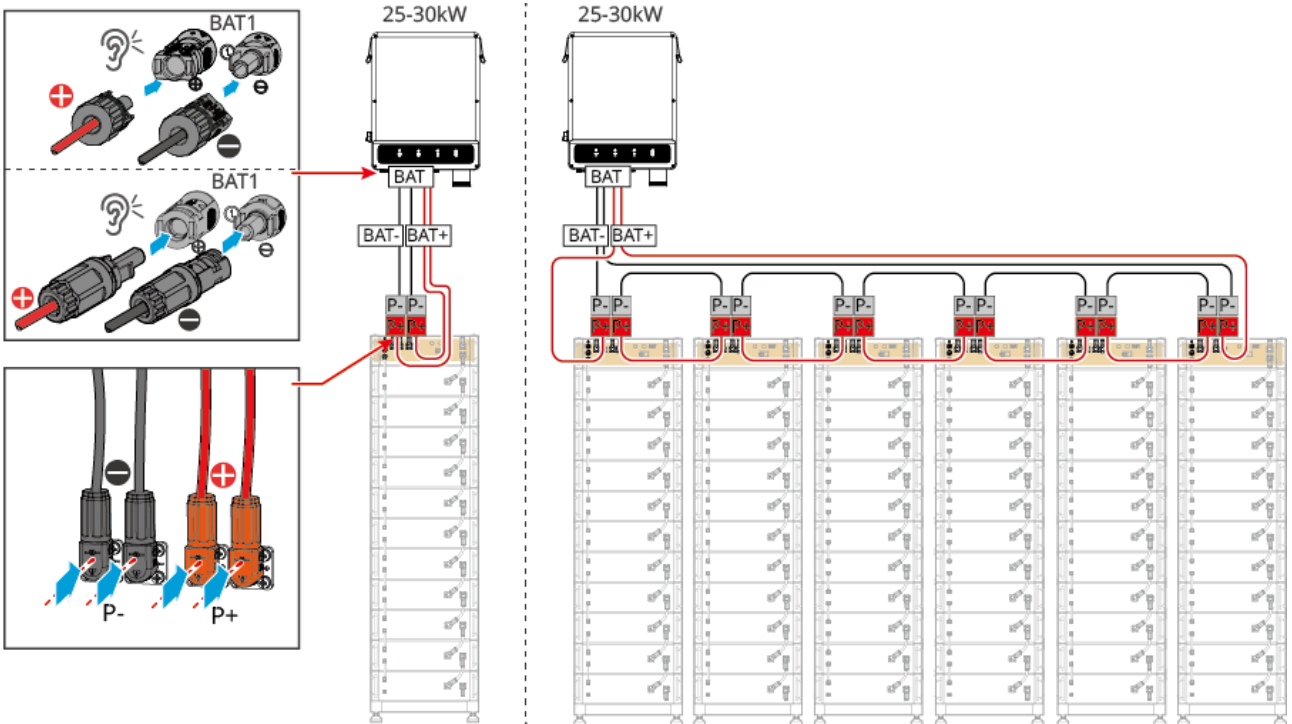
### Wiring Overview

- 15-20kW inverters have only one BAT port; connect one circuit when used with a battery.



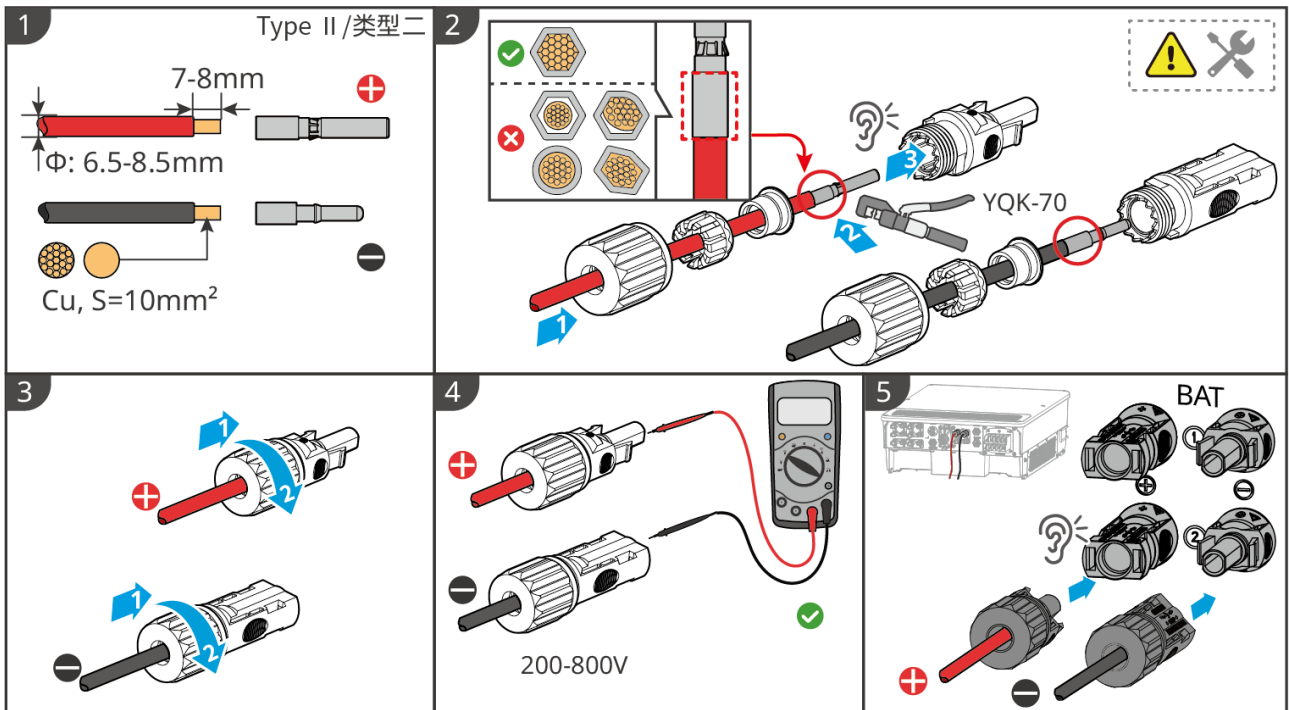
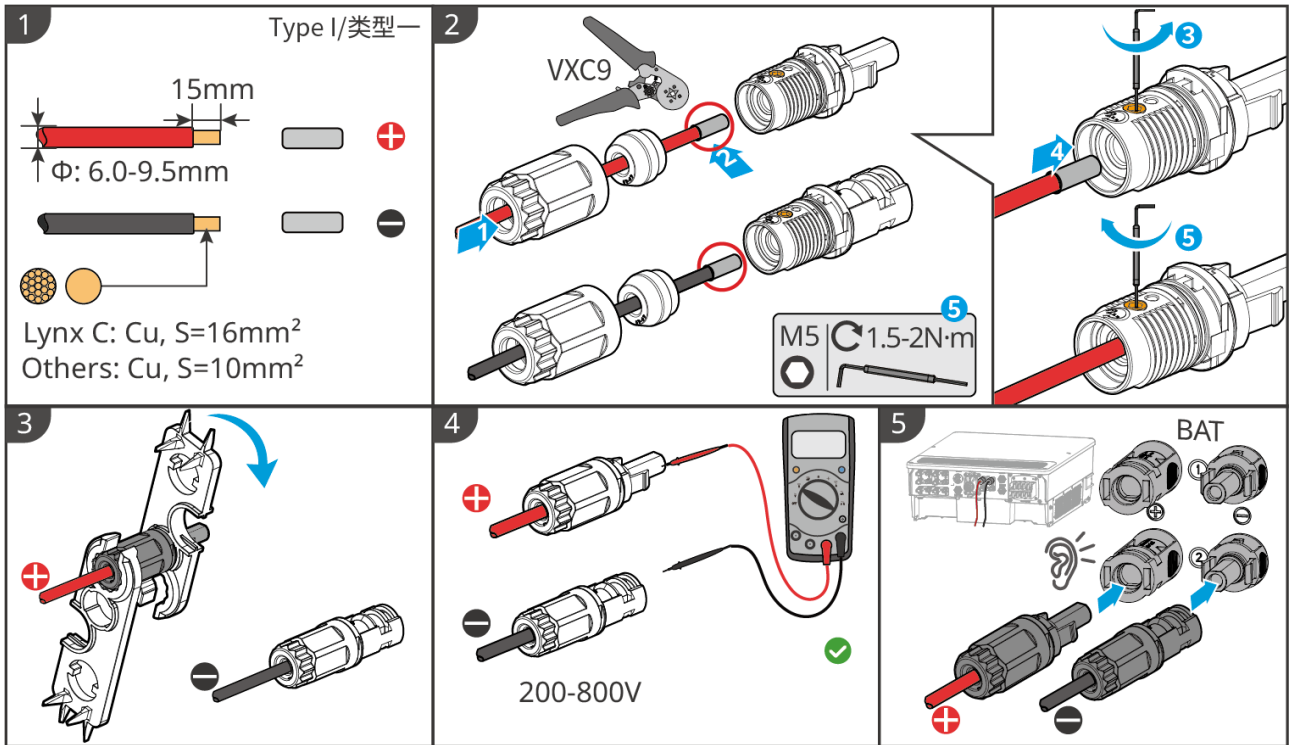
ET3010ELC0038

- 25-30kW inverters have two BAT ports; connect two circuits when used with a battery.

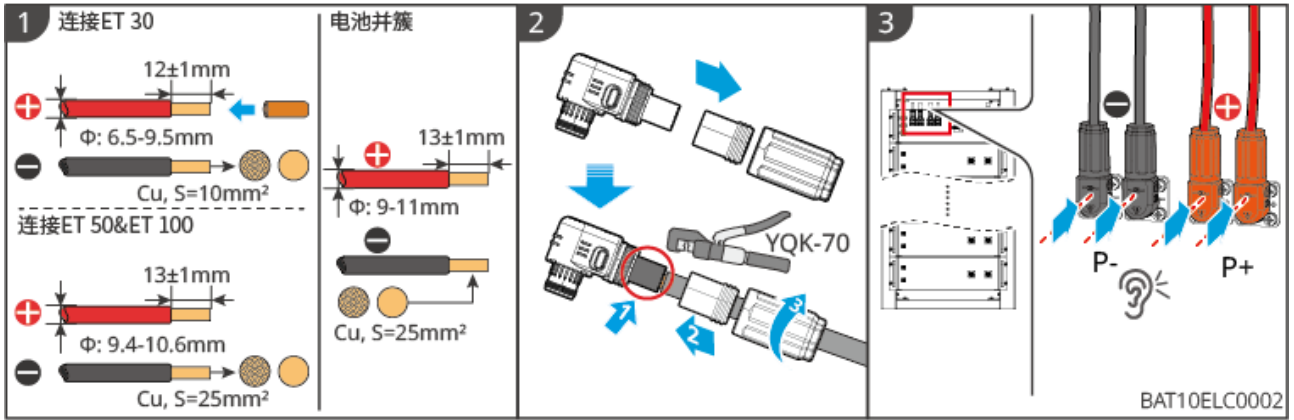


ET3010ELC0039

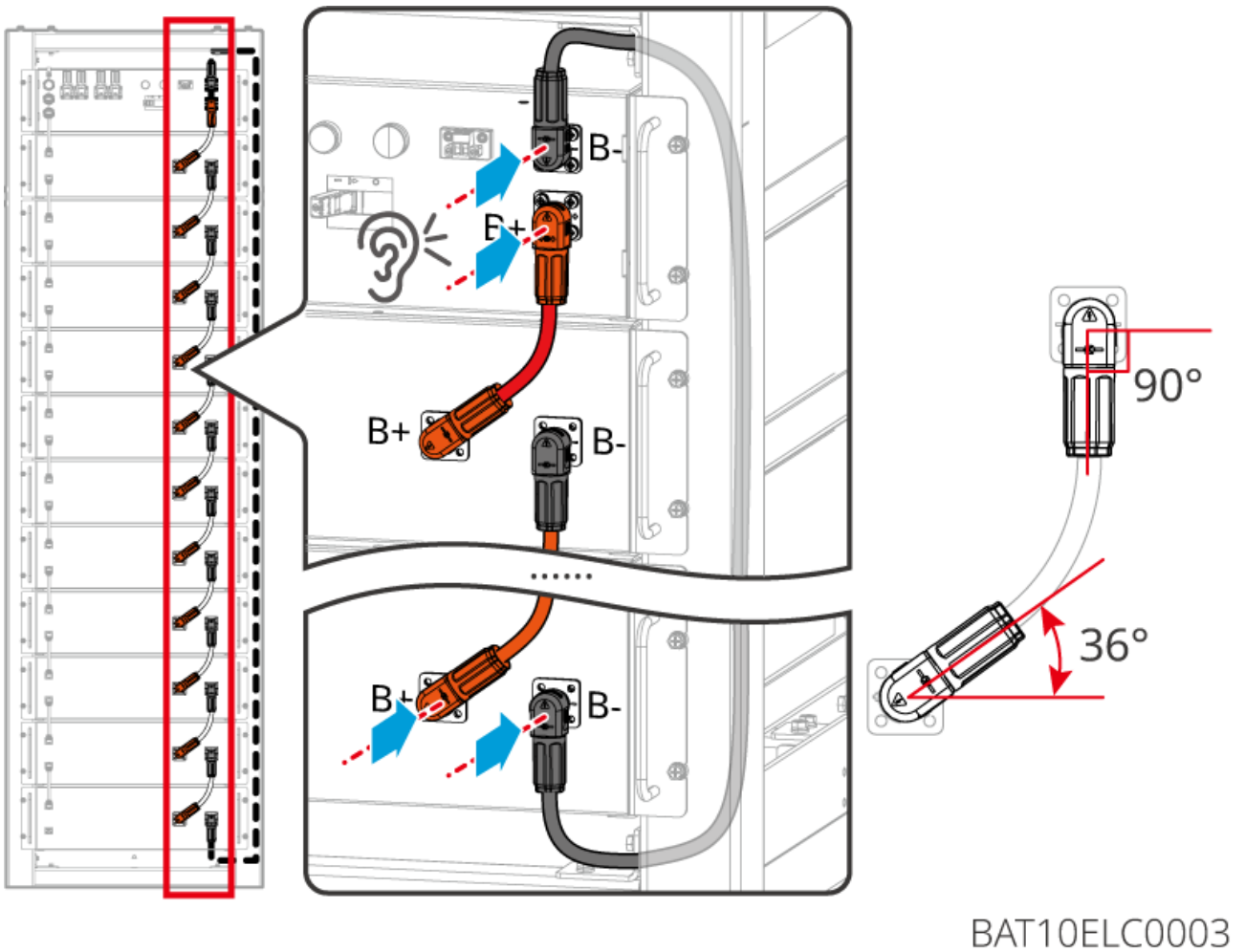
## How to Make Cables at the Inverter End



## How to Make Cables at the Battery End (Including Parallel Cluster Wiring)



### 5.6.2.2 Connecting Battery Power Lines



### 5.6.2.3 Connecting Communication Cables

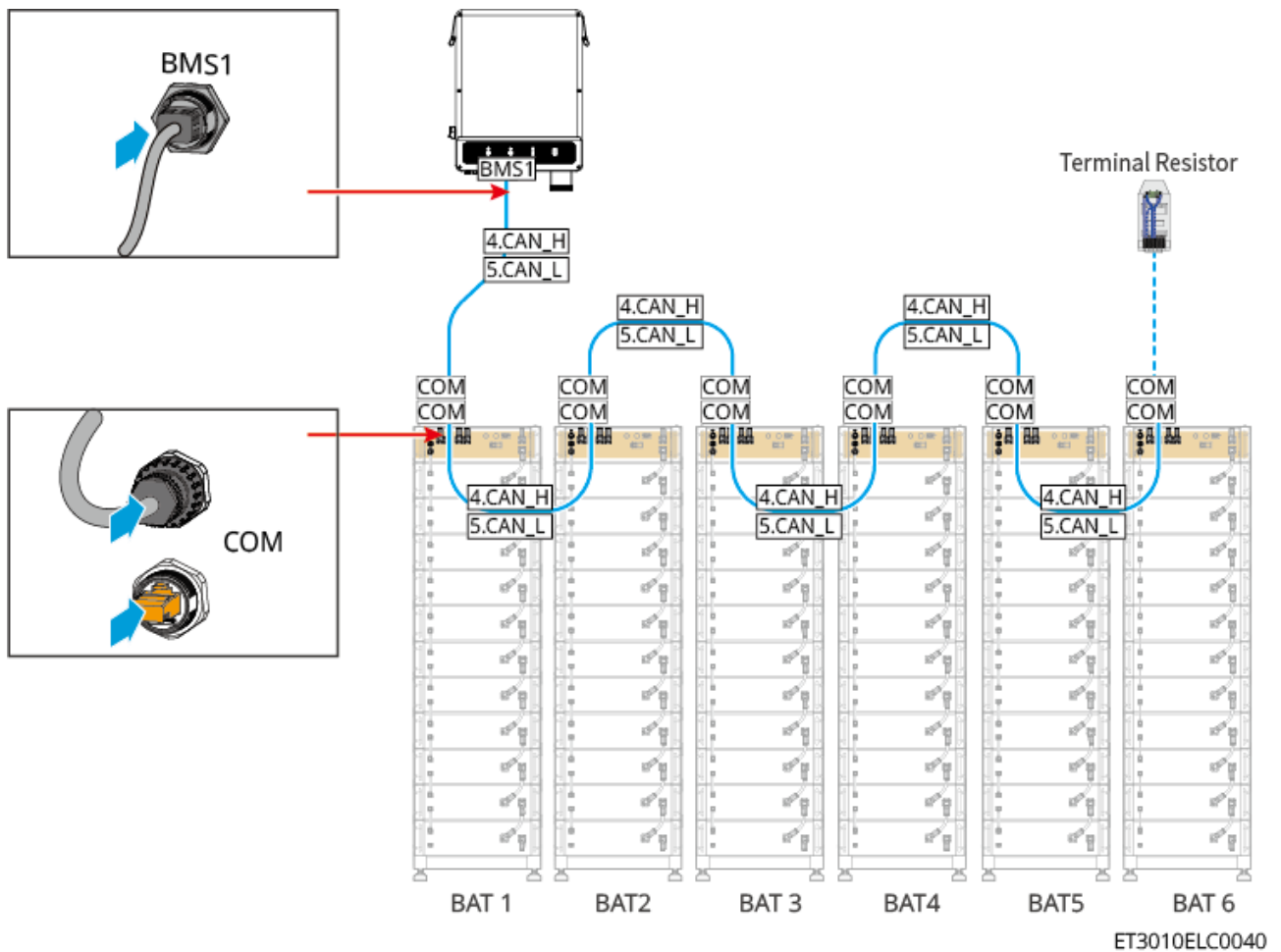
## NOTICE

The battery system is shipped with a communication cable. Please use the communication cable provided in the package.

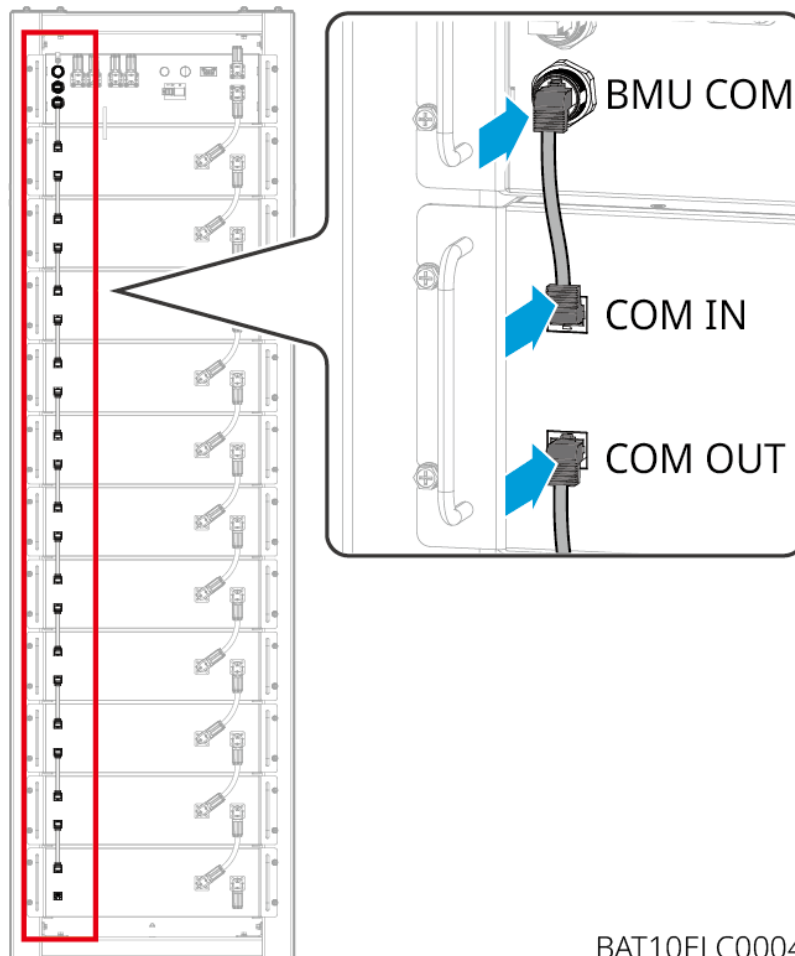
Instructions for BMS Communication Connection between Inverter and Battery:

Port	Definition	Description
COM1、COM2	1: RS485_A1 2: RS485_B1	Communication with inverter (reserved).
	4: CAN_H 5: CAN_L	Communication with inverter or cluster parallel communication.

### Inverter and Battery Communication Wiring



## Communication Wiring between Battery PACKs



BAT10ELC0004

### NOTICE

When connecting communication cables between battery PACKs, do not connect wires to the COM OUT port of the bottommost PACK; no terminating resistor is required!

### 5.6.3 Paired with BAT-C Series 61.4-112.6kWh Commercial & Industrial Battery System

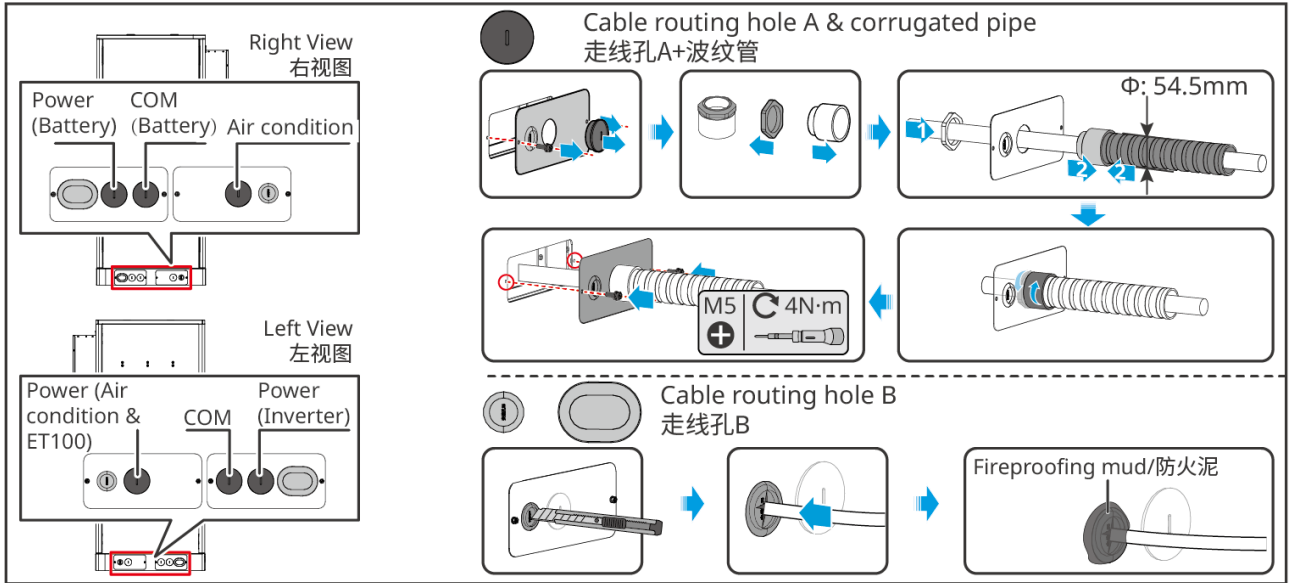
Inverter	GW15K-ET	GW20K-ET	GW25K-ET	GW29.9K-ET	GW30K-ET
Number of BAT Ports	1	1	2	2	2

Inverter		GW15K-ET	GW20K-ET	GW25K-ET	GW29.9K-ET	GW30K-ET
With BAT 61.4kWh Battery System	Wiring Method	Connect to 1 BAT port	Connect to 1 BAT port	Connect to 2 BAT ports	Connect to 2 BAT ports	Connect to 2 BAT ports
	Can it be fully loaded?	Yes	No	Yes	Yes	Yes
With BAT 92.1kWh Battery System	Wiring Method	Connect to 1 BAT port	Connect to 1 BAT port	Connect to 2 BAT ports	Connect to 2 BAT ports	Connect to 2 BAT ports
	Can it be fully loaded?	Yes	Yes	Yes	Yes	Yes
With BAT 102.4kWh Battery System	Wiring Method	Connect to 1 BAT port	Connect to 1 BAT port	Connect to 1 BAT port	Connect to 2 BAT ports	Connect to 2 BAT ports
	Can it be fully loaded?	Yes	Yes	Yes	Yes	Yes
With BAT 112.6kWh Battery System	Wiring Method	Connect to 1 BAT port	Connect to 1 BAT port	Connect to 1 BAT port	Connect to 2 BAT ports	Connect to 2 BAT ports
	Can it be fully loaded?	Yes	Yes	Yes	Yes	Yes

### 5.6.3.1 Battery Cable Pass-Through and System Wiring Overview

** WARNING**

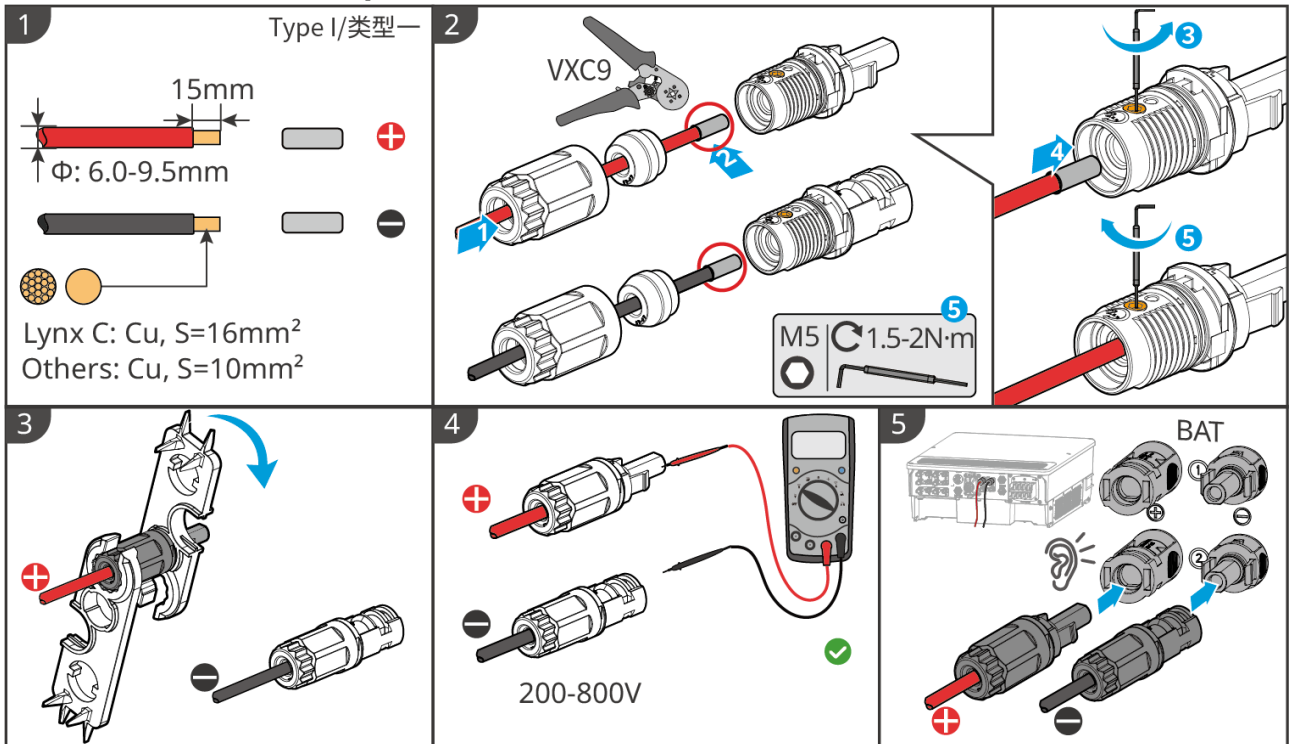
All cut cable holes must be sealed with fireproof putty.



BAT10INT0014

### 5.6.3.2 Connecting the Power Cable between the Inverter and Battery

#### Inverter End Cable Preparation Method



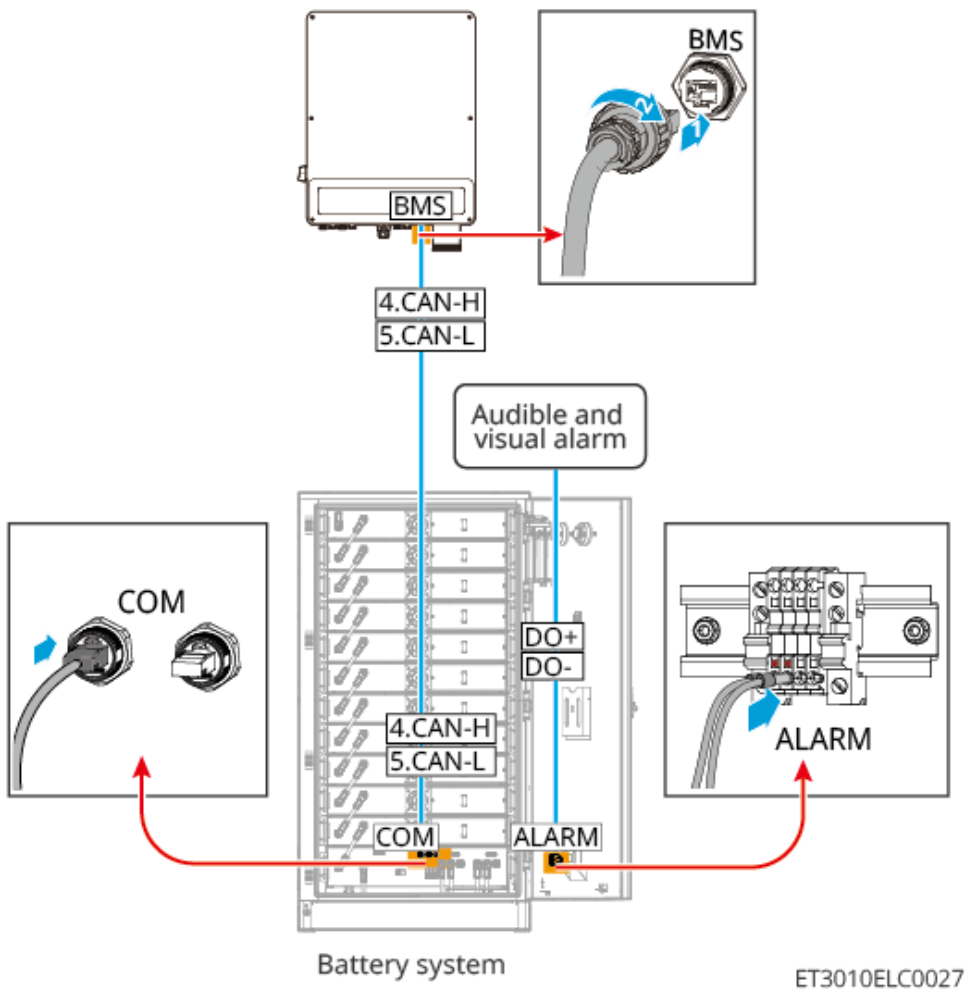
ET3010ELC0031

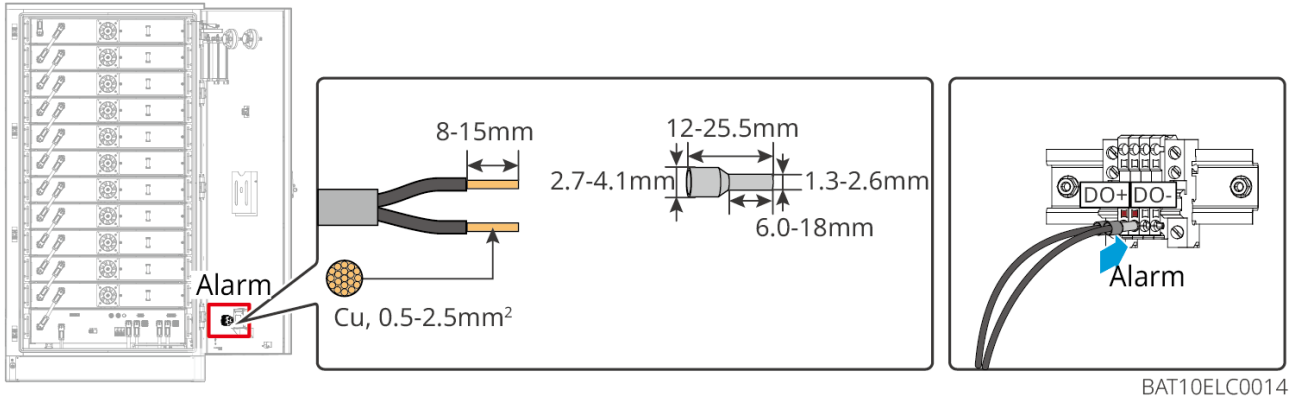


### 5.6.3.3 Connecting the Battery Communication Cable

#### NOTICE

- A communication cable is included with the battery system. Please use the provided communication cable.
- The battery system's external communication ports are pre-fitted with terminal resistors. If you need to connect a communication cable, please remove the terminal resistor. Retain the terminal resistor on any port not connected to a communication cable.





### Instructions for BMS Communication Connection between Inverter and Battery:

Port	Definition	Description
1-3, 6-8	-	-
4	CAN_H	Communication with inverter
5	CAN_L	

#### 5.6.3.4 Connecting Battery Air Conditioning Cables

##### Wiring Steps:

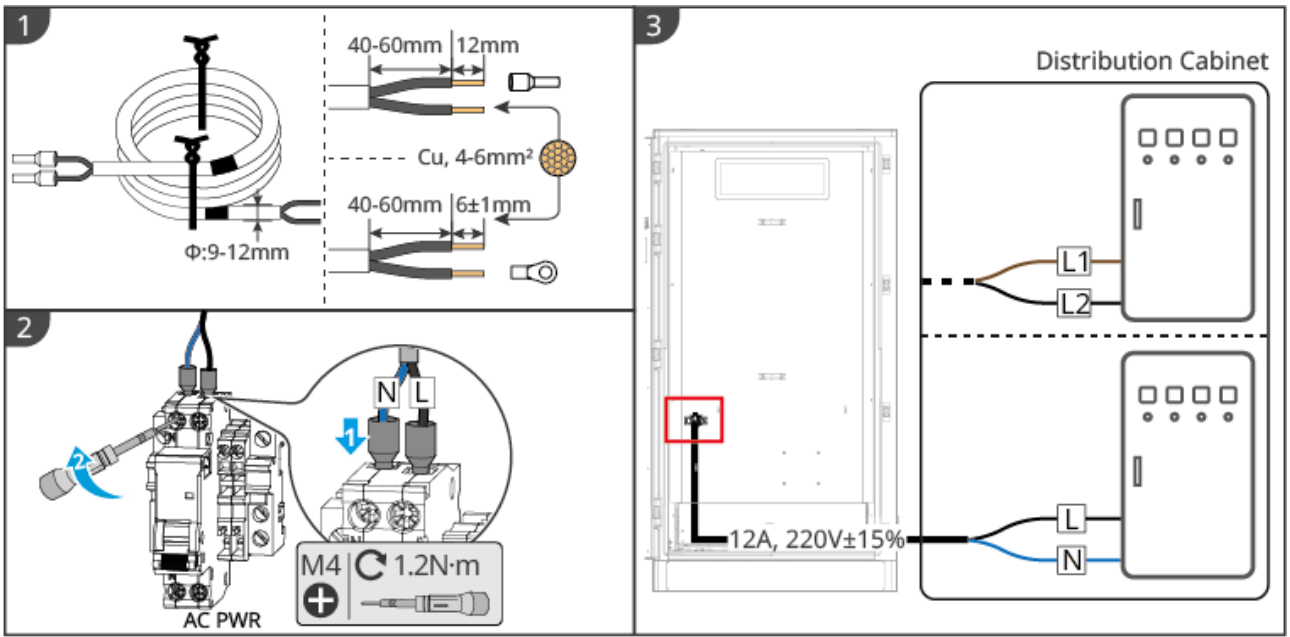
Step 1: Prepare the air conditioning cable.

Step 2: Connect the cable to the battery's air conditioning switch.

Step 3: Connect the cable directly to the distribution board or to the inverter's BACKUP port via the distribution board.

#### NOTICE

Please ensure the air conditioner power cord voltage is  $220V \pm 15\%$  and the rated current is 12A.



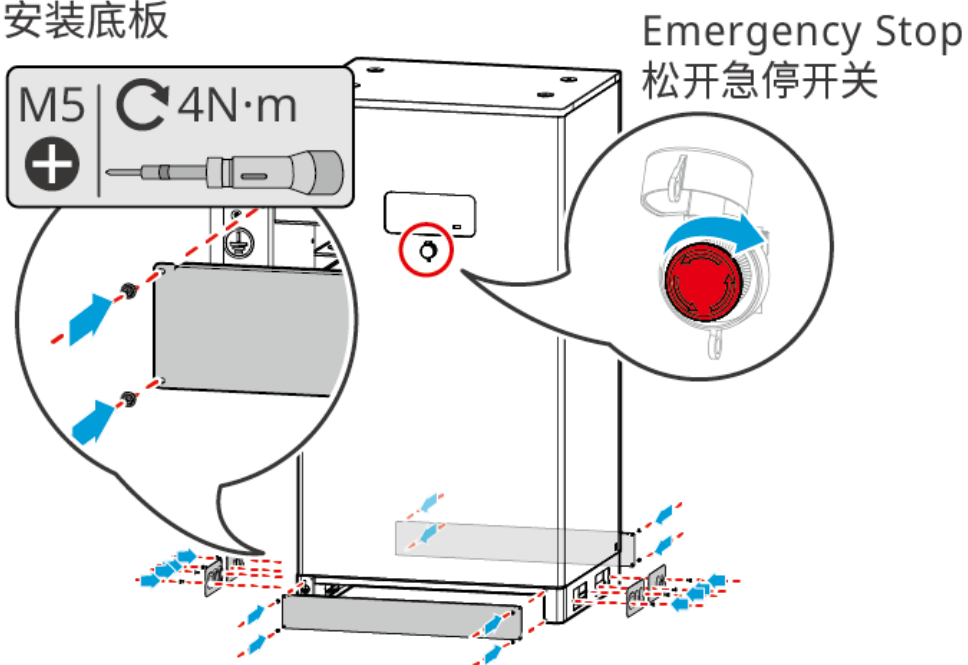
BAT10ELC0016

### 5.6.3.5 Install Base Plate and Release Emergency Stop Switch

After wiring is completed, please reinstall the cover at the bottom of the battery in the original way, and rotate right to release the emergency stop switch.

Pedestal installation

安装底板



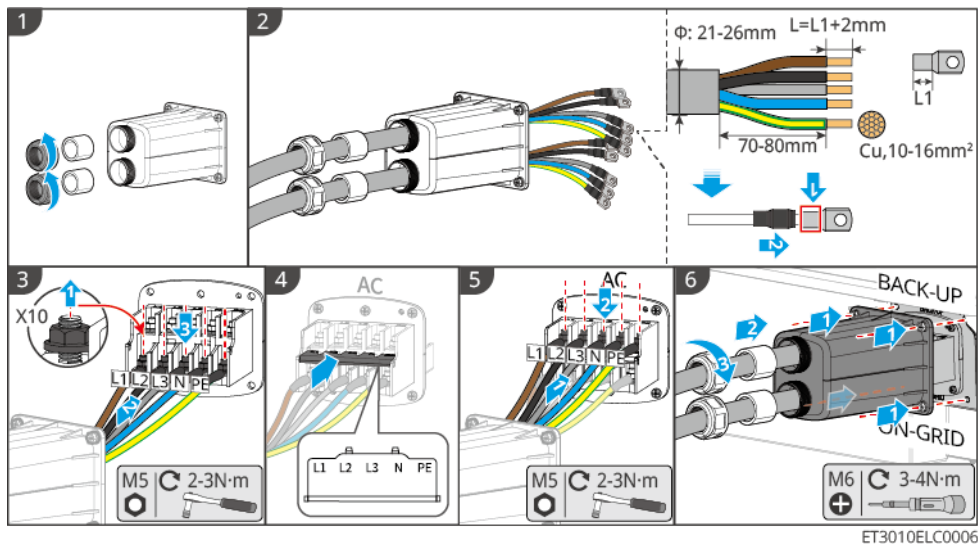
BAT10INT0009

## 5.7 Connecting the AC Cable

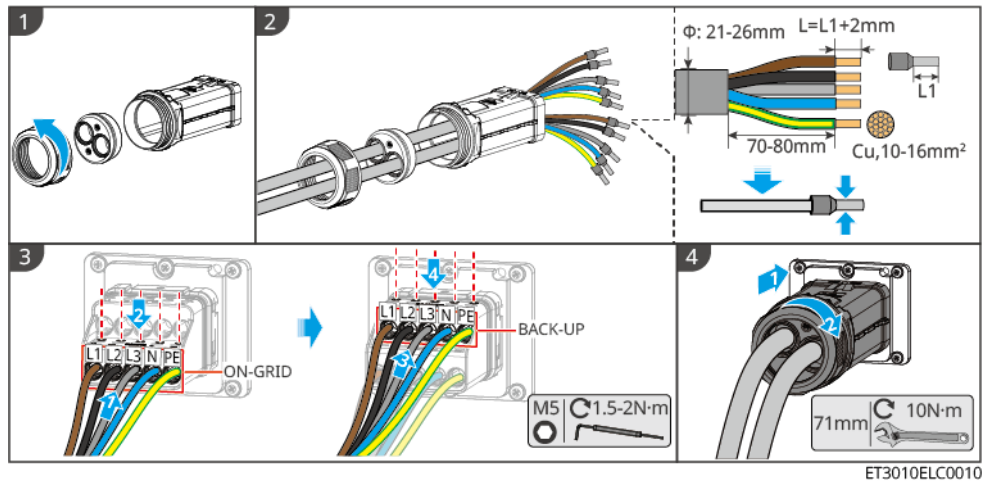


- The inverter internally integrates a Residual Current Monitoring Unit (RCMU) to prevent residual current from exceeding the specified value. When the inverter detects a leakage current greater than the allowable value, it will quickly disconnect from the grid or generator.
- During wiring, ensure that the AC wires completely match the AC terminal ports “L1”, “L2”, “L3”, “N”, and “PE”. Incorrect cable connections may cause equipment damage.
- Ensure that the wire cores are fully inserted into the terminal connection holes without exposure.
- Ensure that the insulation plate at the AC terminal is tightly secured without looseness.
- Ensure that the cable connections are tight; otherwise, during equipment operation, it may cause terminal overheating and equipment damage.

Type 1:



Type 2:



## 5.8 Connecting the Meter Cable

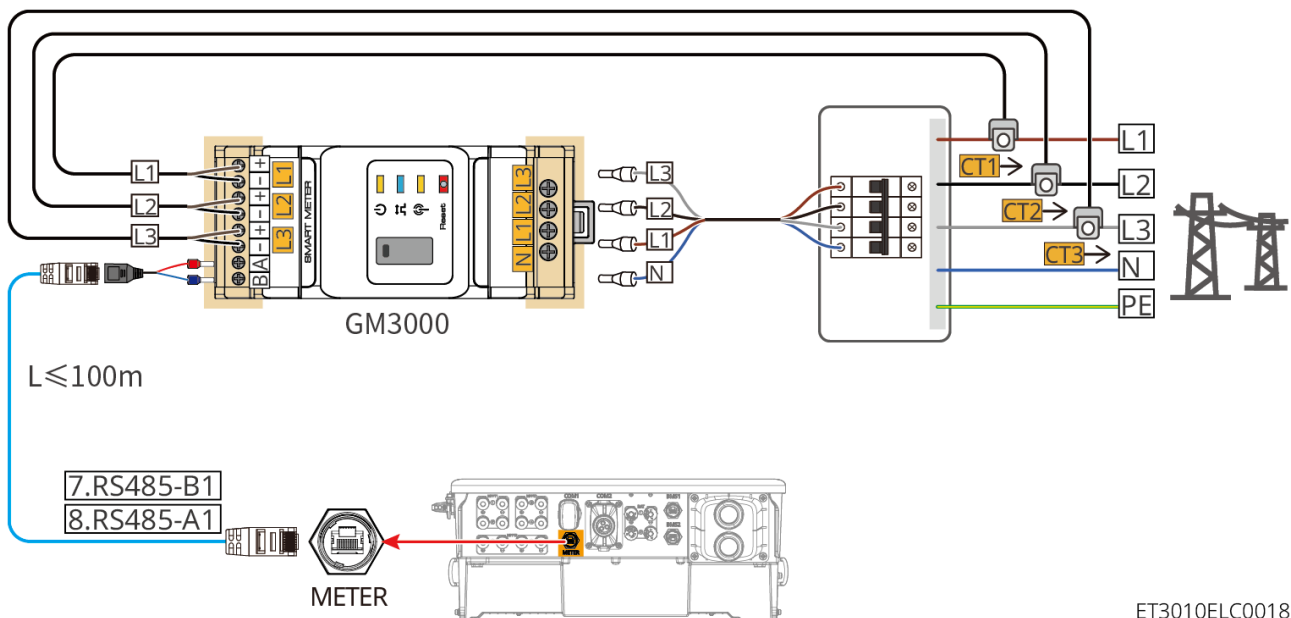
### NOTICE

- The meter shipped with the box is intended for use with a single inverter only. Do not connect one meter to multiple inverters. For applications requiring multiple inverters, please consult the manufacturer to purchase additional meters separately.
- Please ensure the CT connection direction and phase sequence are correct; otherwise, it may lead to inaccurate monitoring data.
- Ensure all cable connections are correct, secure, and not loose. Improper wiring may cause poor contact or damage the meter.
- In areas with lightning risk, if the meter cable length exceeds 10m and the cable is not routed using a grounded metal conduit, it is recommended to install an external lightning protection device.

### GM3000 Meter Wiring

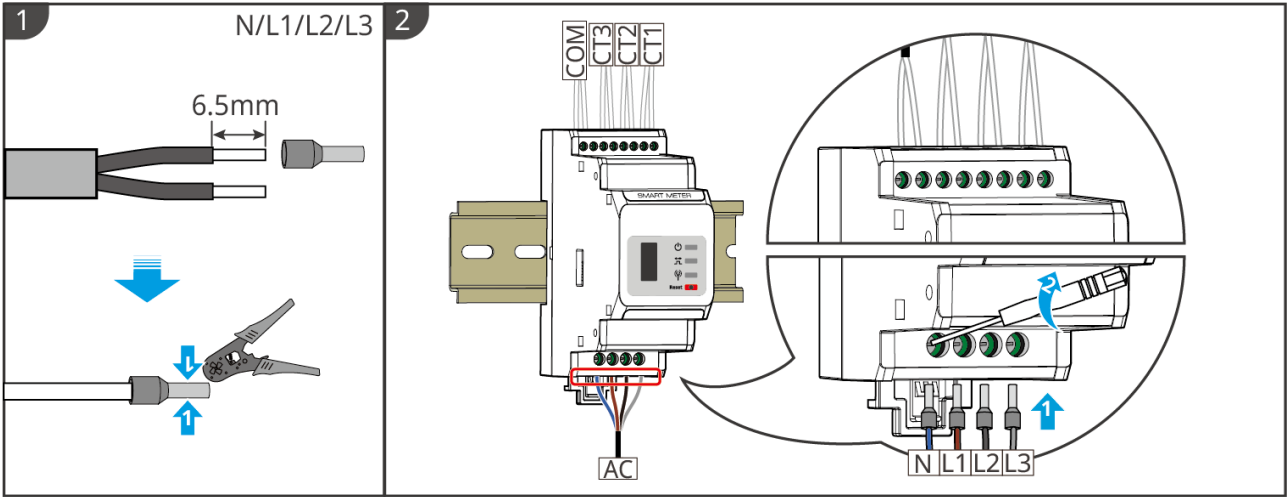
## NOTICE

- The outer diameter of the AC power line must be smaller than the aperture of the CT to ensure the AC power line can pass through the CT.
- To ensure the current detection accuracy of the CT, the recommended CT cable length should not exceed 30m.
- Do not use network cable as the CT cable, as excessive current may cause damage to the meter.
- The CTs provided by equipment manufacturers may vary slightly in size and appearance depending on the model, but the installation and wiring methods are the same.



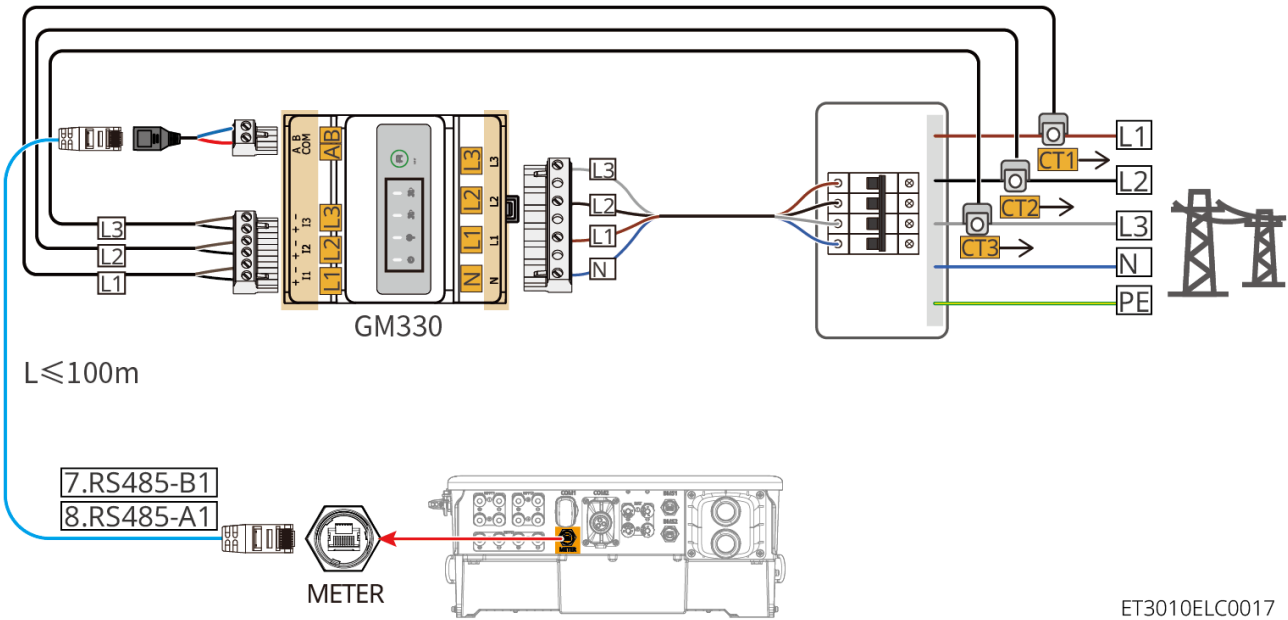
ET3010ELC0018

## Wiring Steps

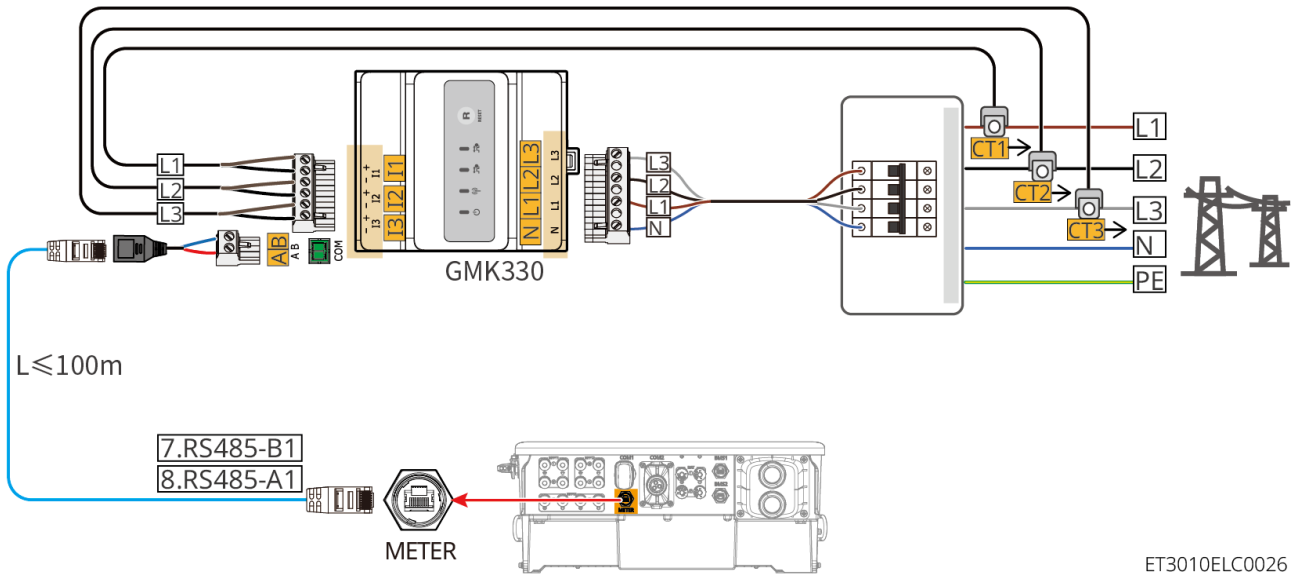


GMK10ELC003

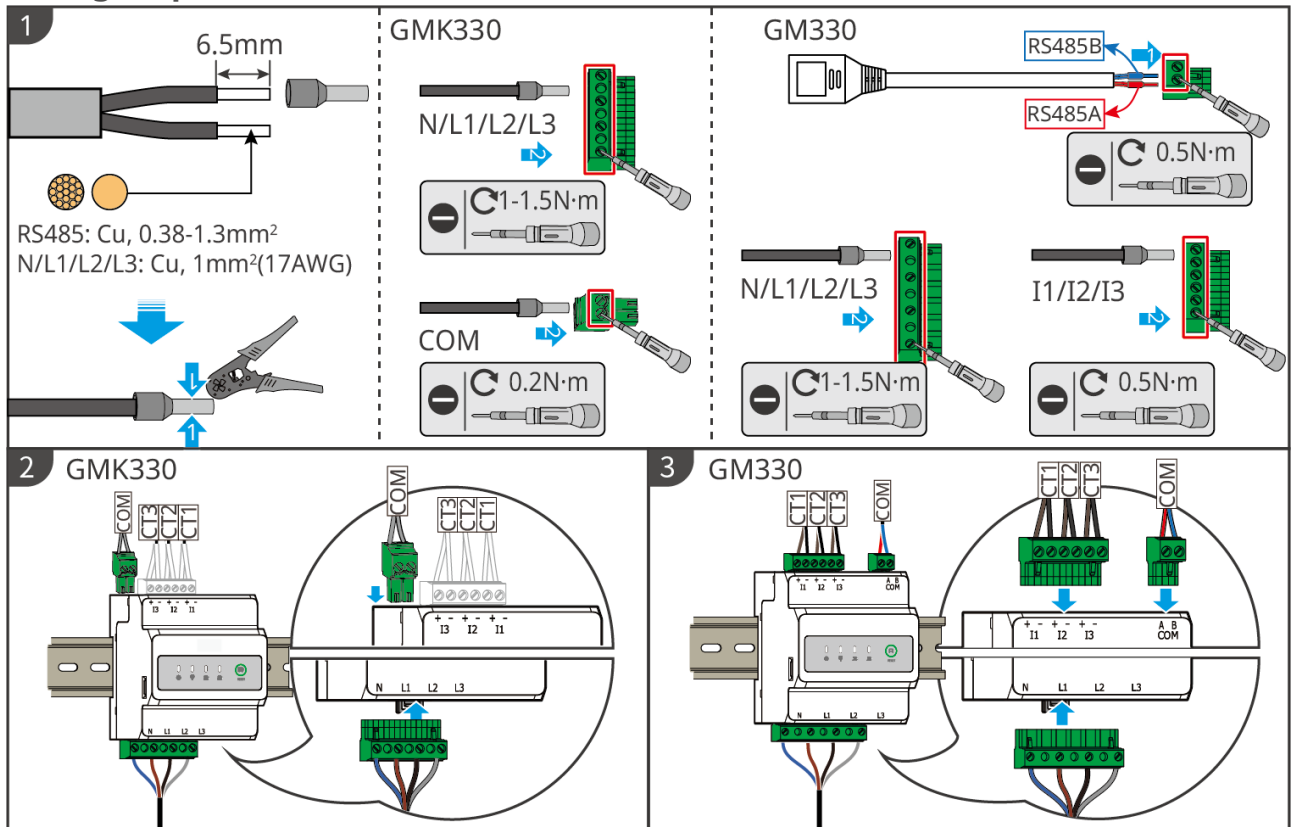
### GM330 & GMK330 Meter Wiring



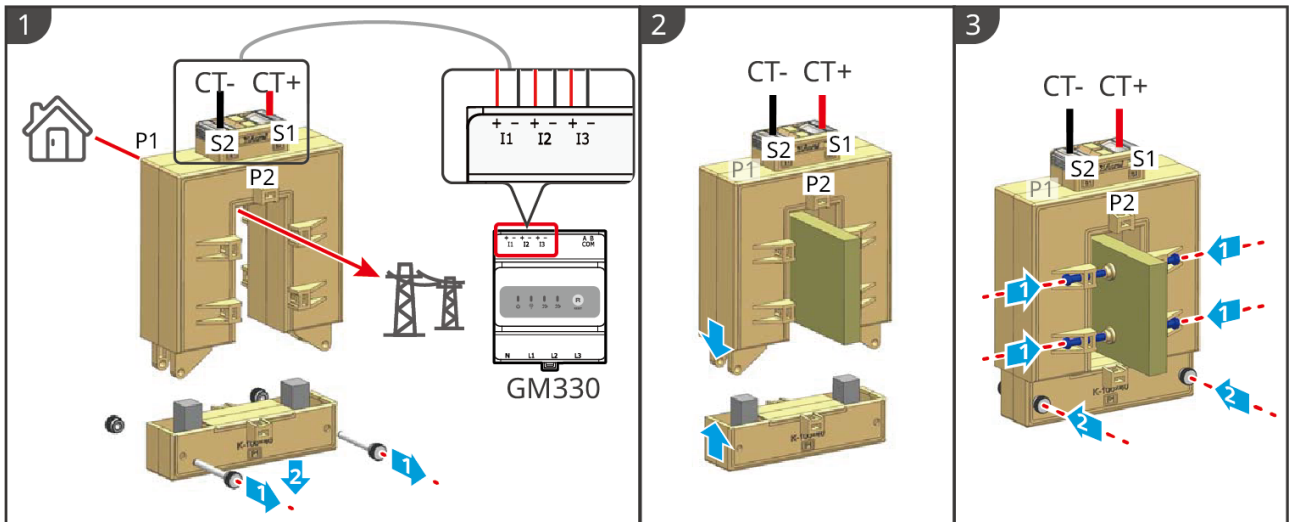
ET3010ELC0017



## Wiring Steps

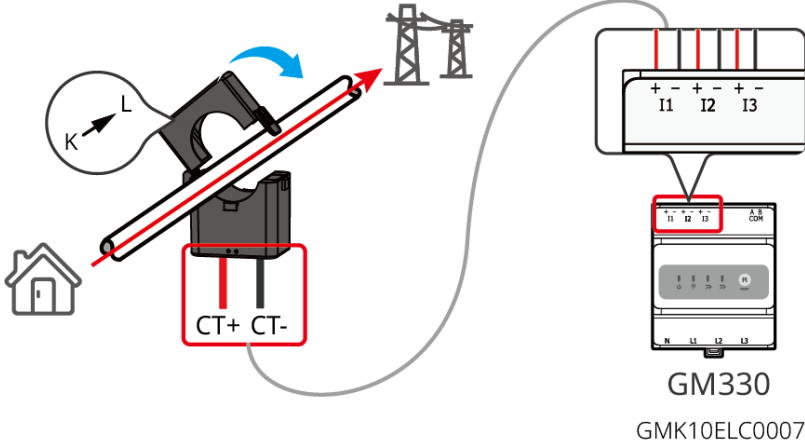


## Installing CT (Type One)



GMK10ELC0006

Installing CT (Type Two)



GMK10ELC0007

## 5.9 Connecting the Inverter Communication Cable

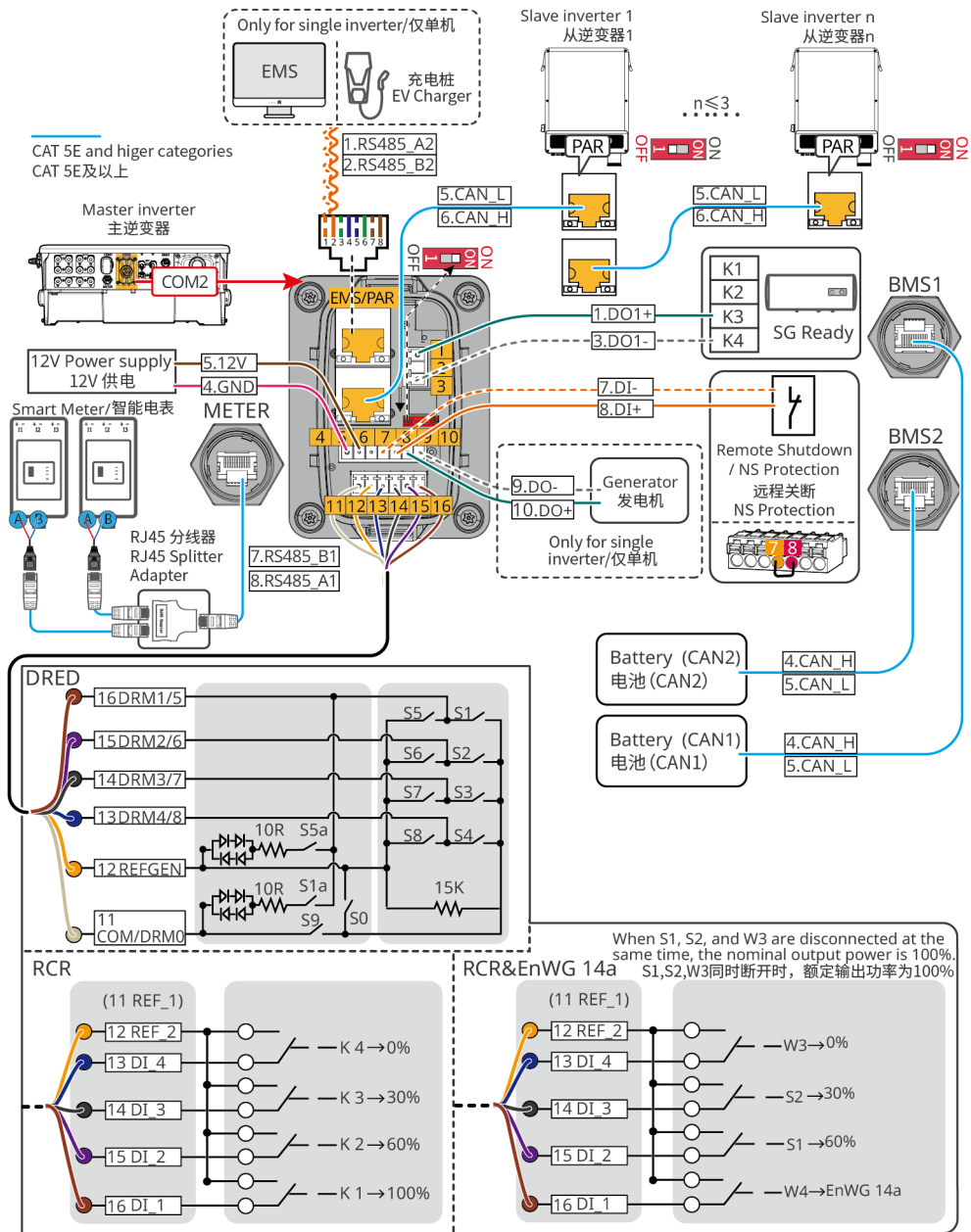
### NOTICE

- To ensure the meter and CT can function properly, please ensure the following:
  - Ensure the CT is connected to the matching phase line: CT1 to L1, CT2 to L2, CT3 to L3.
  - Connect according to the direction indicated on the CT; otherwise, a CT reverse fault may occur.
  - When replacing or maintaining the CT later, use the "Meter/CT - Auxiliary Detection" function in the SolarGo APP to allow the Inverter to readapt to the CT sampling current direction.

## NOTICE

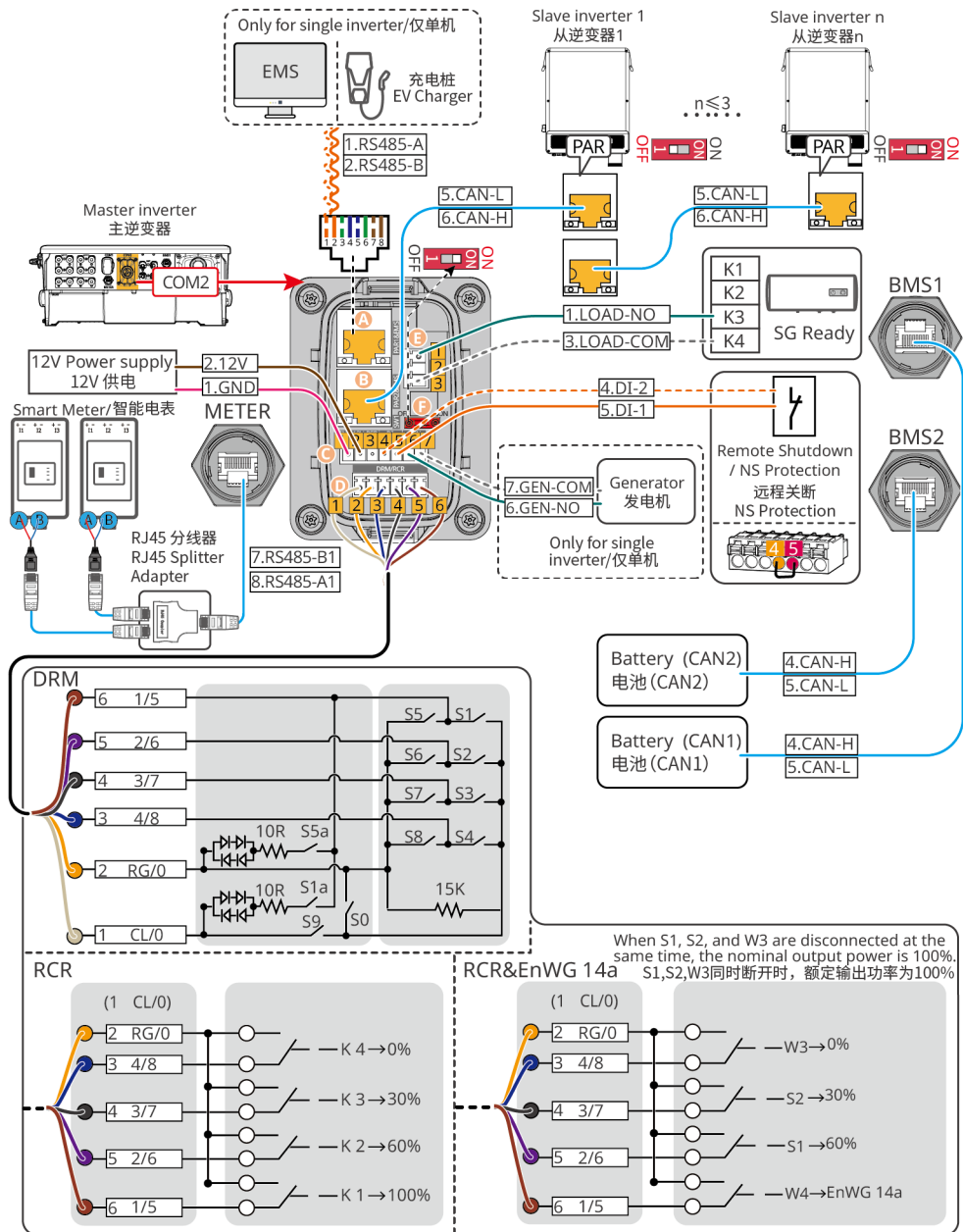
- If you need to use the DRED, RCR, or remote shutdown function, please enable it in the SolarGo APP after wiring is completed.
- Do not enable the function in the SolarGo APP if the Inverter is not connected to a DRED device or remote shutdown device, otherwise the Inverter will not be able to operate in grid-connected mode.
- In a parallel system, to implement DRED or RCR functions, only connect the DRED/RCR communication lines to the master Inverter.
- The Inverter's DO signal communication port can connect to dry contact signals with specifications:  $\text{Max} \leq 24\text{Vdc}$ , 1A.
- The Inverter supports connection to a phone or WEB interface via 4G, Bluetooth, WiFi, or LAN communication methods to set device parameters, view device operating information and error messages, and stay informed of system status.
- In a single-unit system, the installation of a WiFi/LAN Kit-20 or 4G Kit-CN-G20 smart communication stick is supported.
- In a parallel system, both the master and slave Inverters need to be installed with a WiFi/LAN Kit-20 smart communication stick for networking.
- When using the 4G Kit-CN-G20:
  - If parallel system networking is required, please contact GoodWe to purchase the WiFi/LAN Kit-20.
  - For the China region, a Micro-SIM card (China Mobile) is standard. Please confirm the device is installed in an area covered by the operator's signal. If local China Mobile signal is not covered, please contact the operator to optimize the signal.
  - Supports connection to third-party monitoring platforms via the MQTT communication protocol.
- The 4G Kit-CN-G20 is an LTE single-antenna device, suitable for application scenarios with lower data transmission rate requirements.
- If you need to use dual meters to achieve grid-connected machine generation monitoring and load consumption monitoring, please use an RJ45 splitter for adaptation. Prepare the RJ45 splitter yourself or contact GoodWe to purchase it.
- To ensure the Inverter's waterproof rating, do not remove the waterproof plugs from unused communication ports on the Inverter.
- The Inverter's communication functions are optional; please select according to the actual usage scenario.

Type One



ET3010ELC0012

Type Two



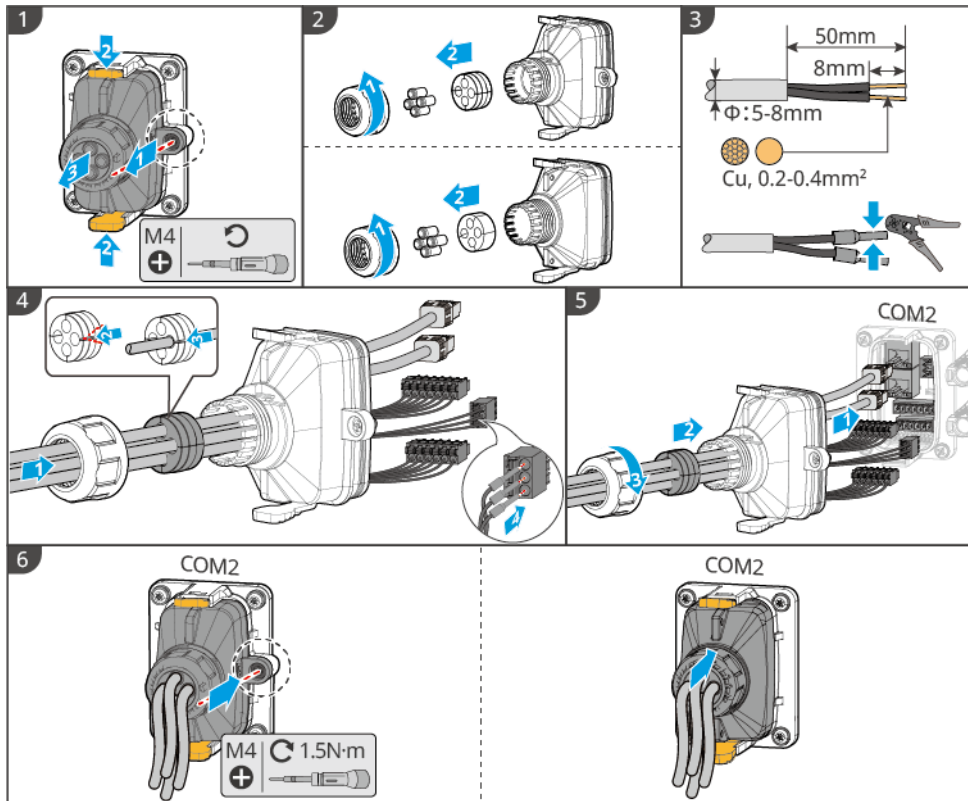
ET3010ELC0033

Silkscreen	Function	Description
DO / LOAD	load control (SG Ready)	<ul style="list-style-type: none"> <li>• Supports connection to dry contact signals to achieve functions such as load control. The DO contact rating is 24V DC@1A, NO/COM normally open contact.</li> <li>• Supports SG Ready heat pump connection, controlling the heat pump via dry contact signals.</li> <li>• Supported operating modes: <ul style="list-style-type: none"> <li>◦ Operating mode 2 (Signal: 0:0 ): Energy-saving Mode. In this mode, the heat pump operates in energy-saving mode.</li> <li>◦ Operating mode 3 (Signal: 0:1 ): Start-up suggestion. In this mode, while maintaining current operation, the heat pump increases hot water reserve to store heat.</li> </ul> </li> </ul>
GND 12V RSD	12V Power Supply	The inverter provides a 12V power supply port, supporting a maximum of 5W device connection. This port has short circuit Protection Function.
DI	Remote Shutdown/NS Protection	<p>Provides a signal control port to control device Remote Shutdown or implement NS Protection Function.</p> <p>Remote Shutdown function:</p> <ul style="list-style-type: none"> <li>• Can control the device to stop working in case of an accident.</li> <li>• The remote shutdown device must be a normally closed switch.</li> <li>• When the inverter uses the RCR or DRED function, ensure the remote shutdown device is connected, or the remote shutdown port is shorted.</li> </ul>

Silkscreen	Function	Description
DO2 / GEN	Generator Start/Stop Control Port	<ul style="list-style-type: none"> <li>• Only supports connection to generator control signals in single inverter scenarios.</li> <li>• The generator control mode is off by default, with the dry contact signal open; after the control mode is enabled, the dry contact signal becomes shorted.</li> </ul>
DRM&RCR /	RCR, DRED, or EnWG 14a Function Connection Port	<ul style="list-style-type: none"> <li>• RCR (Ripple Control Receiver): Provides an RCR signal control port to meet grid dispatch requirements in regions like Germany.</li> <li>• DRED (Demand Response Enabling Device): Provides a DRED signal control port to meet DERD certification requirements in regions like Australia.</li> <li>• EnWG (Energy Industry Act) 14a: All controllable loads must accept emergency dimming from the grid. Grid operators can temporarily reduce the maximum grid power purchase of controllable loads to 4.2kW.</li> </ul>
EMS/PAR/PAR-1/PAR1&EMS	<ul style="list-style-type: none"> <li>• EMS Communication or EV Charger Communication Port</li> <li>• Parallel Communication Port</li> </ul>	<ul style="list-style-type: none"> <li>• CAN and BUS port: Parallel communication port. CAN communication is used in parallel networking to connect to other inverters; the BUS bus controls the on-grid/off-grid status of each inverter in the parallel system.</li> <li>• RS485 port: Used to connect to third-party EMS devices and EV chargers. Connecting third-party EMS devices and EV chargers is not supported in parallel scenarios.</li> </ul>

<b>Silkscreen</b>	<b>Function</b>	<b>Description</b>
EMS/PAR / PAR1&EMS / PAR2&EMS	Parallel Communication Port	<ul style="list-style-type: none"> <li>• CAN and BUS port: Parallel communication port. CAN communication is used in parallel networking to connect to other inverters; the BUS bus controls the on-grid/off-grid status of each inverter in the parallel system.</li> </ul>
S1	Parallel DIP Switch	<p>Inverter parallel DIP switch. By default, it is set to the ON position from the factory.</p> <p>In multi-unit parallel scenarios, the parallel DIP switches of the first and last inverters need to be set to the ON position, and other inverters set to the 1 position.</p>
METER	Smart Meter Connection Port	Connects to a smart meter to achieve output power control, load monitoring, and other functions.
BMS1 / BMS2	Battery Communication Connection Port	<p>Connects to batteries using CAN communication.</p> <p>GW12KL-ET, GW15K-ET, GW20K-ET: 1 GW18KL-ET, GW25K-ET, GW29.9K-ET, GW30K-ET: 2</p>

### **Method for connecting the communication cable**

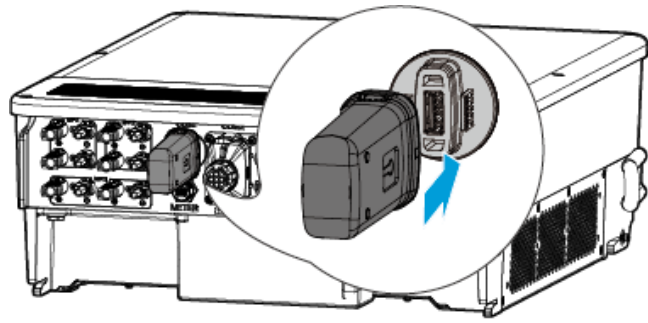


ET3010ELC0009

## 5.10 Connecting the Smart Communication Stick

## NOTICE

- The inverter supports connecting to a mobile phone or the WEB interface via Bluetooth, 4G, WiFi, LAN Smart Dongle to set device-related parameters, view device operation information and error messages, and keep track of the system status in a timely manner.
- When the system contains multiple inverters connected in a network, the master inverter needs to be installed with the Ezlink3000 Smart Dongle for networking.
- For an energy storage system with only one inverter, the WiFi-Kit, WiFi/LAN Kit-20, or 4G Smart Dongle can be used.
- When using the WiFi communication method to connect the inverter to a router, you can install the WiFi-Kit, WiFi/LAN Kit-20, or Ezlink3000 Smart Dongle.
- When using the LAN communication method to connect the inverter to a router, you can install the WiFi/LAN Kit-20 or Ezlink3000 Smart Dongle.
- When using the 4G communication method to upload the energy storage system operation information to the monitoring platform, you can install the LS4G Kit-CN, 4G Kit-CN, 4G Kit-CN-G20, or 4G Kit-CN-G21 Smart Dongle. When using LS4G Kit-CN or 4G Kit-CN, the Smart Dongle shipped with the inverter is required to configure the parameters of the energy storage system. After configuration is complete, replace it with LS4G Kit-CN or 4G Kit-CN for data transmission. When using 4G Kit-CN-G20 or 4G Kit-CN-G21, please use the Bluetooth signal emitted by the module for local device configuration.
- The 4G module is an LTE single-antenna device, suitable for application scenarios with lower requirements for data transmission rates.
- The built-in SIM card in the 4G module is a China Mobile communication card. Please confirm whether the device is installed in an area covered by China Mobile's 4G signal.
- After installing the 4G Kit-CN-G20 or 4G Kit-CN-G21 communication dongle, please contact the after-sales service center to bind the inverter with the communication dongle. After binding, if you need to install the communication dongle on another inverter, please contact the after-sales service center to unbind it first.
- To ensure 4G signal communication quality, do not install the device indoors or in areas with metal interference signals.



ET3010ELC0034

# 6 System Commissioning

## 6.1 Check Before Power ON

No.	Check Item
1	The equipment is installed securely. The installation location facilitates operation and maintenance, the installation space allows for ventilation and heat dissipation, and the installation environment is clean and tidy.
2	The PE cable, DC cable, AC cable, Communication cable, and terminal resistor are connected correctly and securely.
3	Cable bundling meets routing requirements, is reasonably distributed, and shows no damage.
4	For unused cable entry holes and ports, ensure they are reliably connected using the terminals provided with the accessories and have been sealed.
5	Ensure that used cable entry holes have been sealed.
6	The voltage and frequency at the inverter grid connection point meet the grid connection requirements.

## 6.2 Power ON

### WARNING

- When multiple inverters are connected in parallel, ensure that the AC side power-up of all slave inverters is completed within one minute after the AC side power-up of the master inverter.
- When multiple battery systems are connected in a cluster, ensure that the QF2 switches of all battery systems are closed within five minutes.  
When multiple battery systems are connected in a cluster, before closing QF1, ensure that the SolarGo App correctly displays the number of battery systems in the cluster; otherwise, it may cause damage to the battery systems.

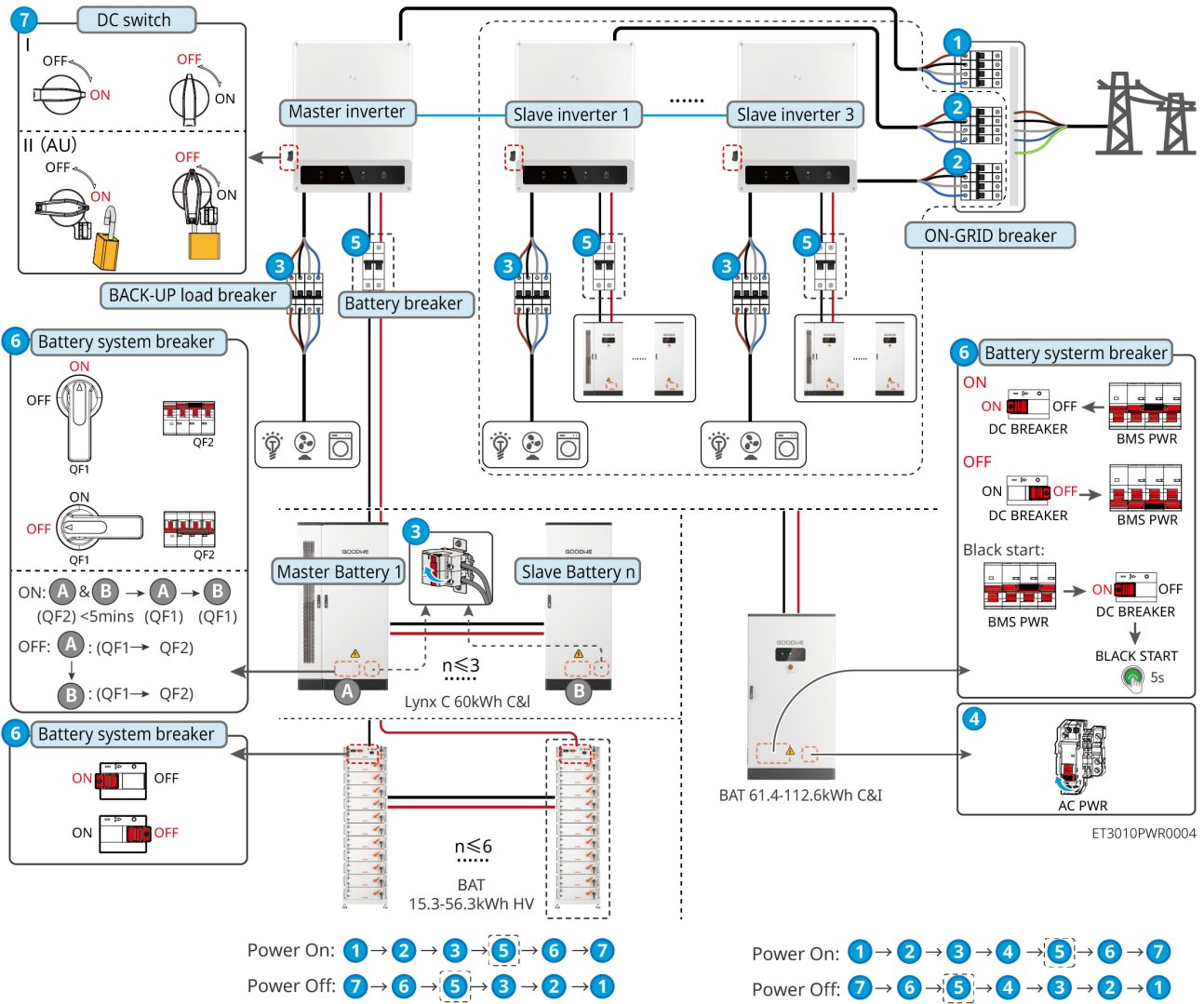
## NOTICE

When there is no PV power generation in the system and the grid is abnormal, if the inverter cannot operate normally, the battery black start function can be used to force the battery to discharge and start the inverter. The inverter can then enter off-grid mode, supplying power to the loads from the battery.

- For the BAT series 92.1-112.6kWh commercial & industrial battery system, the black start procedure is the same as the power-on steps.
- The black start procedure for other batteries is the same as the power-on steps.

BAT series 92.1-112.6kWh commercial & industrial battery system: Before performing the power-on operation, ensure the battery's emergency stop switch is in the released state. Release procedure: Rotate the emergency stop switch to the right.






















⑤: Optional based on local laws and regulations.

## 6.3 Indicators

### 6.3.1 Inverter Indicators

Indicator	Status	Description
		The inverter is powered on and in standby mode
		The inverter is starting up and in self-check mode
		The inverter is operating normally in grid-connected power generation or off-grid mode
		BACK-UP output overload

Indicator	Status	Description
		System fault
		The inverter is powered off
		Grid abnormal, inverter BACK-UP port power supply normal
		Grid normal, inverter BACK-UP port power supply normal
		No power supply at BACK-UP port
		Inverter monitoring module resetting
		No connection established between inverter and communication terminal
		Communication fault between communication terminal and cloud server
		Inverter monitoring normal
		Inverter monitoring module not started

### 6.3.2 Battery Indicators

- Lynx C series 60kWh commercial and industrial battery system



**Run**














**Warning**



**Fault**

LXC10010DSC0002

Indicator	Status	Description
 Run		Steady green: Device operating normally
		Single green blink: Battery operating normally, not communicating with the inverter
		Two green blinks: Device in standby
		Green off, steady yellow: Device warning Green off, steady red: Device fault Green, yellow, and red all off: Device not powered on

Indicator	Status	Description
 Warning		Steady on: Device warning
		Off: No device warning
 Fault		Steady on: Device fault
		Off: No device fault

• **BAT-S series 15.3-56.3kWh high-voltage battery**











**RUN**



**FAULT**

BAT10DSC0003

Indicator	Status	Description
 RUN		Solid green light: Device operating normally
		Single green blink: Battery operating normally, not communicating with the inverter
		Two green blinks: Device in standby
 FAULT		Solid red light: Device fault
		Single red blink: System under-voltage level 3~4
		Two red blinks: SN anomaly

• **BAT-C series 61.4-112.6kWh commercial and industrial battery system**



**Run**





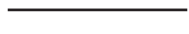

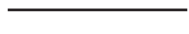










**Warning**






**Fault**

LXC10010DSC0002

indicator	Status	Description
 Run		Steady green: Device operating normally
		Green single flash: Battery operating normally, not communicating with the inverter
		Green double flash: Device in standby
		Green off, steady yellow: Device warning
 Warning		Green off, Steady red: Device fault
		Green, yellow, and red all off: Device not powered on
 Fault		Steady on: Device warning
		Off: No device warning
		Steady on: Device fault
 Fault		Off: No device fault
		Red single flash: Hibernation (under-voltage)




### 6.3.3 Smart Meter Indicator

#### GM330&GMK330

Type	Status	Description
Power Light 	Steady On	The meter is powered on, with no RS485 communication
	Blinking	The meter is powered on, RS485 communication is normal
	Off	The meter is powered off
Communication Light 	Off	Reserved
	Blinking	Press the Reset button for $\geq 5s$ , the Power Light and Buy/Sell Light blink: Meter reset
Buy/Sell Light 	Steady On	buy power from the grid
	Blinking	Sell power to the grid
	Off	Not buying or selling power


Type	Status	Description
	Reserved	


### GM3000

Type	Status	Description
Power Light 	Constantly On	Meter is powered on
	Off	Meter is powered off
Buy/Sell Light 	Constantly On	buy power from the grid
	Blinking	Selling power to the grid
Communication Light 	Blinking	Normal communication
	Continuous blinking 5 times	<ul style="list-style-type: none"> <li>Press the Reset button for &lt;3s: Meter reset</li> <li>Press the Reset button for 5s: Meter parameters restored to factory defaults</li> <li>Press the Reset button for &gt;10s: Meter parameters restored to factory defaults, energy data cleared</li> </ul>
	Off	No communication from the meter

### 6.3.4 Smart Dongle Indicator











- **Wi-Fi Kit**

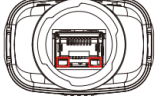
Indicator	Color	Status	Description
Power indicator 	Green	On	Wi-Fi Kit is powered on.
		Off	Wi-Fi Kit is not powered on or is restarting.
	Blue	On	WiFi AP hotspot is connected.

Commu nication indicato r  		Off	<ul style="list-style-type: none"> <li>• Wi-Fi Kit communication is abnormal.</li> <li>• Wi-Fi Kit is restarting.</li> </ul>
---	--	-----	--

• WiFi/LAN Kit-20



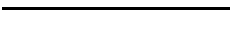





NOTICE	
<ul style="list-style-type: none"> <li>• After double-clicking the Reload button to enable Bluetooth, the communication indicator will switch to a single-blink state. Please connect to the SolarGo APP within 5 minutes, otherwise Bluetooth will automatically turn off.</li> <li>• The single-blink state of the communication indicator only occurs after enabling Bluetooth by double-clicking the Reload button.</li> </ul>	


Indicat or	Status	Description
Power light  		Steady on: The Smart Communication Stick is powered on.
		Off: The Smart Communication Stick is not powered on.
Commu nication light  		Steady on: Communication is normal in WiFi mode or LAN mode.
		Single blink: The Smart Communication Stick's Bluetooth signal is on, waiting to connect to the SolarGo app.
		Two blinks: The Smart Communication Stick failed to connect to the router.
		Four blinks: The Smart Communication Stick communicates normally with the router but failed to connect to the server.
		Six blinks: The Smart Communication Stick is identifying the connected device.
		Off: The Smart Communication Stick is undergoing a software reset or is not powered on.

Indicator	Color	State	Description
LAN Port Communication Light 	Green	Solid	100Mbps wired network connection is normal.
		Off	<ul style="list-style-type: none"> <li>• Network cable is not connected.</li> <li>• 100Mbps wired network connection is abnormal.</li> <li>• 10Mbps wired network connection is normal.</li> </ul>
	Yellow	Solid	10/100Mbps wired network connection is normal, with no communication data being transmitted or received.
		Blinking	Communication data is being transmitted or received.
		Off	Network cable is not connected.

Button	Description
Reload	Hold for 0.5~3 seconds, the smart communication stick will reset.
	Hold for 6~20 seconds, the smart communication stick will restore factory settings.
	Double-click quickly to enable Bluetooth signal (only lasts 5 minutes).



• 4G Kit-CN-G20 & 4G Kit-CN-G21

Indicator	Status	Description
		Steady on: The smart communication stick is powered on.
		Off: The smart communication stick is not powered on.
		Steady on: The smart communication stick is connected to the server, communication is normal.
		Double flash: The smart communication stick is not connected to the communication base station.
		Four flashes: The smart communication stick is connected to the communication base station but not connected to the server.
		Six flashes: Communication between the smart communication stick and the inverter is disconnected.








Indicator	Status	Description
		Off: The smart communication stick is undergoing a software reset or is not powered on.

Button	Description
RELOAD	Hold for 0.5~3 seconds, the Smart Communication Stick will restart.
	Hold for 6~20 seconds, the Smart Communication Stick will be restored to factory settings.

• **LS4G Kit-CN, 4G Kit-CN**

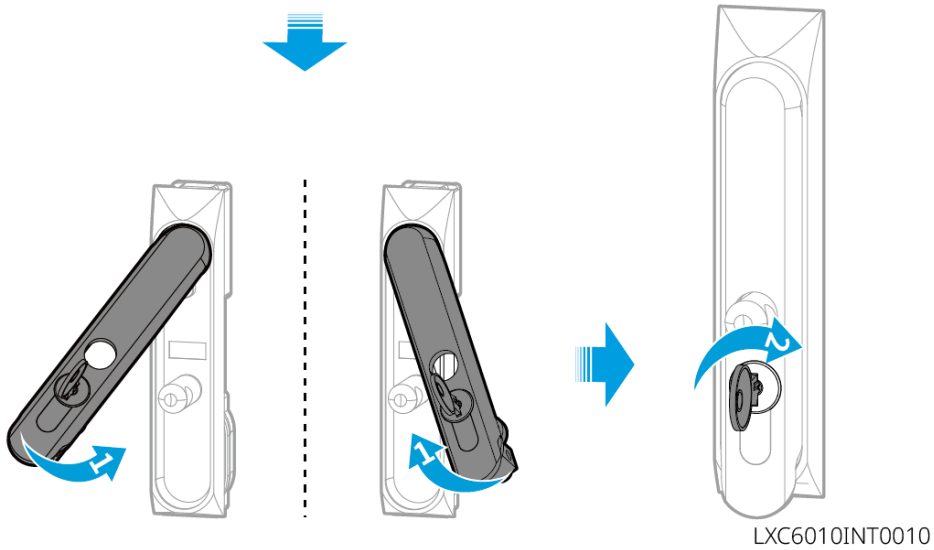
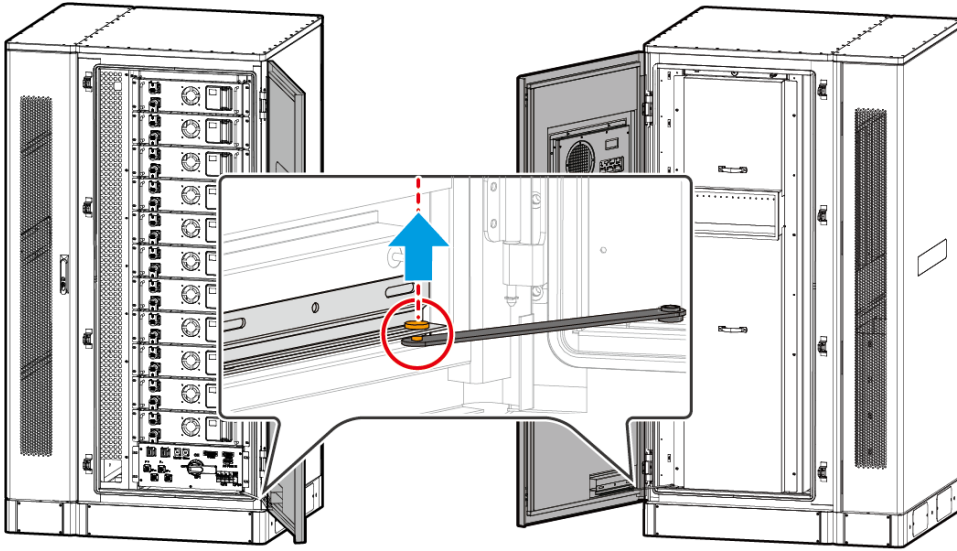
Indicator	Color	Status	Description
Power indicator 	Green	On	Module is secured and powered on
		Off	Module is not secured or not powered on
Communi cation indicator 	Blue	Slow blinking (0.2s on, 1.8s off)	<ul style="list-style-type: none"> <li>• Inverter communication indicator blinks 2 times: Dialing, searching for network</li> <li>• Inverter communication indicator blinks 4 times: Failed to connect to the cloud due to no data flow</li> </ul>
		Slow blinking (1.8s on, 0.2s off)	<ul style="list-style-type: none"> <li>• Inverter communication indicator blinks 2 times: Dialing successful</li> <li>• Inverter communication indicator steady on: Cloud connection successful</li> <li>• Inverter communication indicator blinks 4 times: Failed to connect to the cloud due to no data flow</li> </ul>
		Fast blinking (0.125s on, 0.125s off)	Inverter is communicating with the cloud via the module
		0.2s on, 8s off	No SIM card installed or poor SIM card contact

• **Ezlink3000**

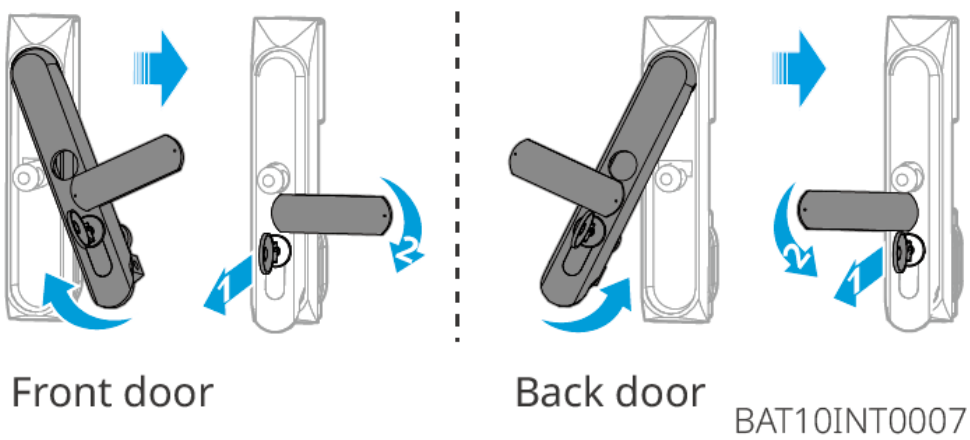
indicator/Silkscreen	Color	Status	Description
Power Light 	Blue		Flashing: The communication stick is operating normally.
			Off: The communication stick is powered off.
Communication Light 	Green		Solid on: The communication stick is connected to the server.
			Double flash: The communication stick is not connected to the router.
			Quadruple flash: The communication stick is connected to the router but not to the server.
RELOAD	-	-	Press and hold for 1-3 seconds to restart the communication stick. Press and hold for 6-10 seconds to restore factory settings. Double-click quickly to enable Bluetooth signal (lasts for 5 minutes only).

## 6.4 Close the Cabinet Door

- Lynx C Series 60kWh Commercial & Industrial Battery System



• **BAT-CSeries 61.4-112.6kWh Commercial & Industrial Battery System**



# 7 System Commissioning and Power Station Monitoring

## 7.1 Setting Inverter Parameters via APP

SolarGo APP is a mobile application software that can communicate with inverters via Bluetooth and WiFi. The following are common functions:

1. View the inverter's operating data, software version, alarm information, etc.
2. Set the inverter's grid parameters, communication parameters, etc.
3. Maintain the device.

For detailed functions, please refer to the "SolarGo APP User Manual". The user manual can be obtained from the official website or by scanning the QR code below.



SolarGo APP



SolarGo APP User Manual

## 7.2 Setting Inverter Parameters via App

SEMS+ App is software used for remote power plant monitoring or local device debugging. It supports installers or owners in:

- Remotely monitoring the operation of the power plant and setting operating parameters for the plant and equipment.
- Locally connecting to devices to view their operation status and set device parameters.

For detailed functions, please refer to the "[SEMS+ App User Manual](#)". The user manual can be obtained from the official website or by scanning the QR code below.



SEMS+ App User Manual

## 7.2.1 Download and Install SEMS+ App

### Phone Requirements:

- Operating System: Android 7.0 or above, iOS 15.1 or above.
- Phone must support a web browser and Internet connection.
- Phone must support WLAN/Bluetooth functionality.

### Download Methods:

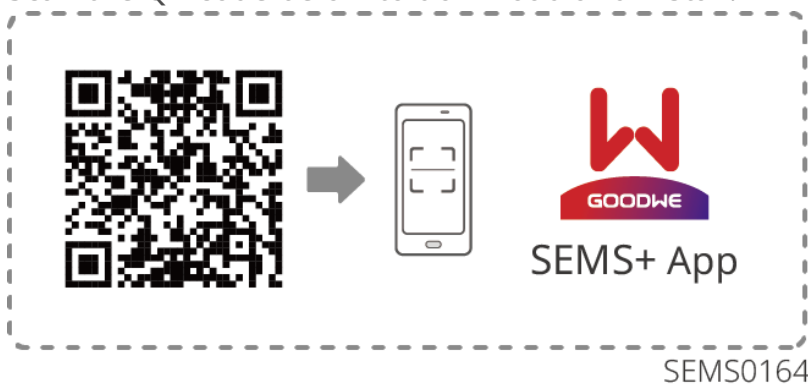
#### Method 1:

Search for SEMS+ on Google Play, App Store, Huawei, Honor, Xiaomi, OPPO, or vivo app stores to download and install.



#### Method 2:

Scan the QR code below to download and install.



## 7.3 Power Plant Monitoring via SEMS+ WEB

SEMS+ WEB is a monitoring platform that can communicate via WiFi or LAN. The following are the common functions of SEMS+ WEB:

1. Manage organization or user information, etc.
2. Add, monitor power plant information, etc.
3. Maintain equipment.

For detailed functions, please refer to the [SEMS+ WEB User Manual](#).



《SEMS+ WEB User Manual》

# 8 Maintenance

## 8.1 Power OFF the System

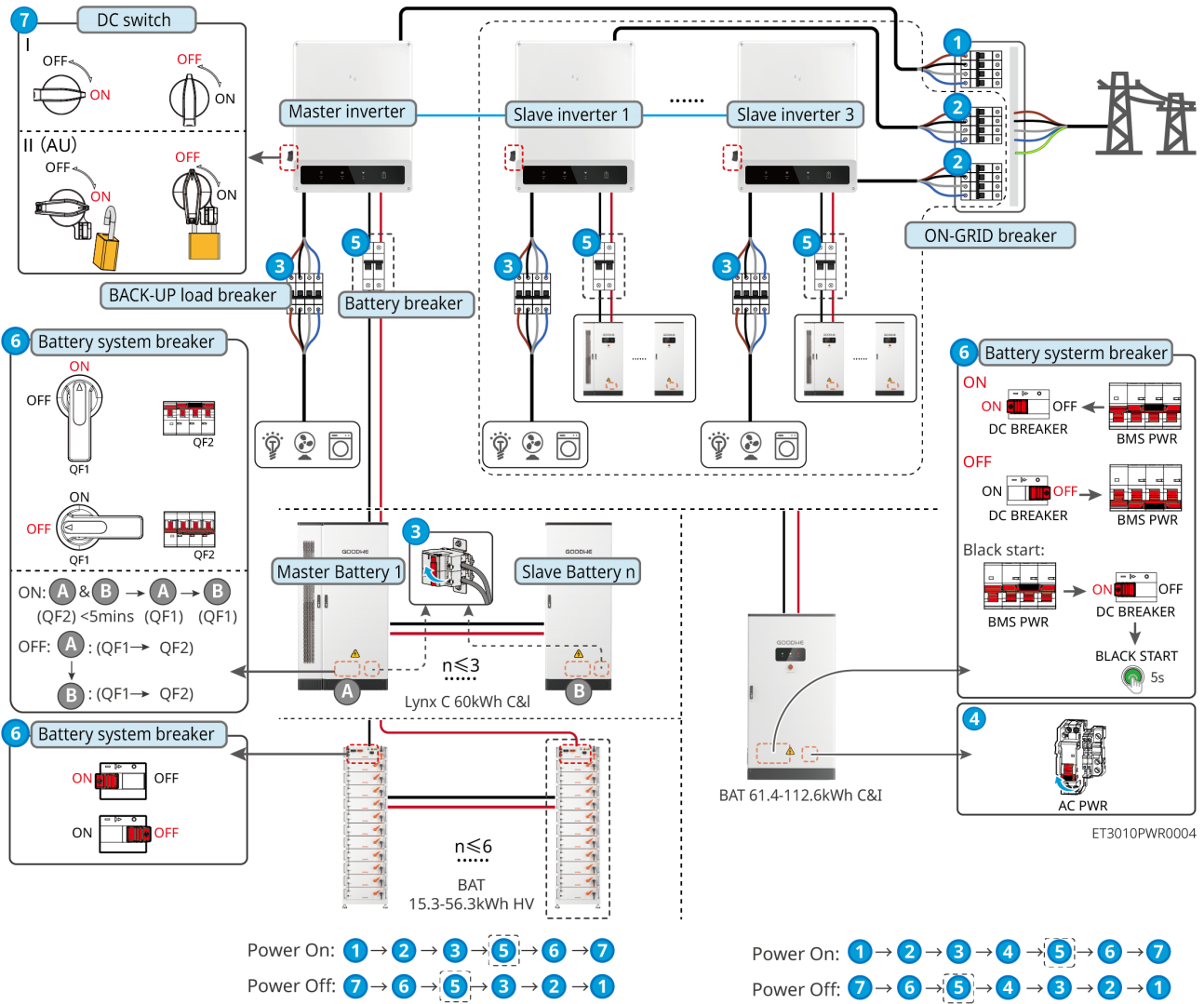
### DANGER

- When performing operation and maintenance on equipment within the system, please power down the system first. Operating equipment while energized may cause equipment damage or electric shock hazards.
- After the equipment is powered off, a certain amount of time is required for the internal components to discharge. Please wait according to the time indicated on the label until the equipment is completely discharged.
- Restarting the battery should be performed using the air switch power-on method.
- When shutting down the battery system, please strictly adhere to the battery system power-off requirements to prevent damage to the battery system.
- When there are multiple batteries in the system, powering off any one battery will power off all batteries.

### NOTICE

- Circuit breakers between the inverter and the battery, and between battery systems, must be installed in accordance with local laws and regulations.
- To ensure effective protection of the battery system, keep the cover of the battery system switch closed; the protective cover should automatically close after being opened. If the battery system switch will not be used for an extended period, secure it with screws.

### Power-Off Procedure



5 : Optional based on local laws and regulations.

## 8.2 Removing the Equipment



- Ensure the device is powered off.
- Wear personal protective equipment when operating the device.
- Use proper disassembly tools when removing wiring terminals to avoid damaging the terminals or the device.
- Unless otherwise specified, the device disassembly method is the reverse of the installation sequence, which will not be repeated in this document.

1. Power down the system.
2. Label the cables connected in the system to indicate their types.
3. Disconnect the cables connected to the Inverter, Battery, and smart meter in the system, such as DC cables, AC cables, Communication cables, and PE cables.
4. Remove equipment such as the smart communication stick, Inverter, Battery, and smart meter.
5. Store the equipment properly. If it will be put into use again later, ensure the storage conditions meet the requirements.

## 8.3 Disposing of the Equipment

When the equipment can no longer be used and needs to be disposed of, please handle it according to the electrical waste disposal requirements of the regulations in the country/region where the equipment is located. Do not dispose of the equipment as general household waste.

## 8.5 fault

### 8.5.1 Viewing Fault/Alarms Information

All detailed fault and alarm information for the energy storage system is displayed in the [SolarGo APP], [SEMS+ App], and [SEMS+ WEB]. If your product is abnormal and you do not see related fault information in the [SolarGo APP], [SEMS+ App], or [SEMS+ WEB], please contact the after-sales service center.

- SolarGo APP

View the energy storage system alarm information via [Home] > [Parameters] > [Alarms].

- SEMS+ App

1. Open the SEMS+ App and log in with any account.
2. View all power station fault information via [power station] > [Alarms].
3. Click on a specific fault name to view details such as the time of occurrence, possible causes, and solutions.

SEMS+ WEB

- Open SEMS+ WEB and log in with any account.
- On the power station details interface, click [Alarms] to view all alarm information for the current power station.

## 8.5.2 Fault Information and Troubleshooting

Please perform troubleshooting according to the following methods. If the troubleshooting methods cannot help you, please contact the after-sales service center.

When contacting the after-sales service center, please collect the following information to facilitate a quick resolution.

1. Product information, such as: serial number, software version, device installation time, fault occurrence time, fault occurrence frequency, etc.
2. Device installation environment, such as: weather conditions, whether components are obstructed, have shadows, etc. It is recommended to provide photos, videos, and other files to assist in problem analysis.
3. Grid situation.

### 8.5.2.1 System Malfunction

If the system experiences an unlisted problem, or if following the instructions does not prevent the issue or abnormality, immediately stop operating the system and contact your dealer at once.

No.	fault	Resolution
1	Unable to search for the Smart Communication Stick's wireless signal	<ol style="list-style-type: none"> <li>1. Ensure no other devices are connected to the Smart Communication Stick's wireless signal.</li> <li>2. Ensure the App is upgraded to the latest version.</li> <li>3. Ensure the Smart Communication Stick is powered normally and the blue indicator light is blinking or steady on.</li> <li>4. Ensure the smart device is within the communication range of the Smart Communication Stick.</li> <li>5. Refresh the App's device list.</li> <li>6. Restart the inverter.</li> </ol>

No.	fault	Resolution
2	Unable to connect to the Smart Communication Stick's wireless signal	<ol style="list-style-type: none"> <li>1. Ensure no other devices are connected to the Smart Communication Stick's wireless signal.</li> <li>2. Restart the inverter or the Communication Stick, then try connecting to the Smart Communication Stick's wireless signal again.</li> <li>3. Ensure Bluetooth encryption pairing is successful.</li> </ol>
3	Unable to find the router SSID	<ol style="list-style-type: none"> <li>1. Place the router closer to the Smart Communication Stick, or add a WiFi repeater to enhance the WiFi signal.</li> <li>2. Reduce the number of devices connected to the router.</li> </ol>
4	After all configuration is complete, the Smart Communication Stick fails to connect to the router	<ol style="list-style-type: none"> <li>1. Restart the inverter.</li> <li>2. Check if the network name (SSID), encryption method, and password in the WiFi configuration match those of the router.</li> <li>3. Restart the router.</li> <li>4. Place the router closer to the Smart Communication Stick, or add a WiFi repeater to enhance the WiFi signal.</li> </ol>
5	After all configuration is complete, the Smart Communication Stick fails to connect to the server	Restart the router and the inverter.

### 8.5.2.2 Inverter Fault

#### 8.5.2.2.1 Troubleshooting (Fault Codes F01-F40)

Fault Code	Fault Name	Fault Cause	Troubleshooting Recommendation
F01	Grid Power Outage	<ol style="list-style-type: none"> <li>1. Grid power outage.</li> <li>2. AC line or AC switch is disconnected.</li> </ol>	<ol style="list-style-type: none"> <li>1. The alarm will disappear automatically after grid power is restored.</li> <li>2. Check if the AC line or AC switch is disconnected.</li> </ol>
F02	Grid Overvoltage Protection	Grid voltage is higher than the allowable range, or the duration of high voltage exceeds the high voltage ride-through setting.	<ol style="list-style-type: none"> <li>1. If it occurs occasionally, it may be a short-term grid anomaly. The inverter will resume normal operation after detecting the grid is normal, requiring no manual intervention.</li> <li>2. If it occurs frequently, check if the grid voltage is within the allowable range. If not, contact the local power operator. If it is, also modify the grid overvoltage protection point after obtaining consent from the local power operator.</li> <li>3. If it cannot recover for a long time, check if the AC side circuit breaker and output cables are properly connected.</li> </ol>

Fault Code	Fault Name	Fault Cause	Troubleshooting Recommendation
F03	Grid Undervoltage Protection	Grid voltage is lower than the allowable range, or the duration of low voltage exceeds the low voltage ride-through setting.	<ol style="list-style-type: none"> <li>1. If it occurs occasionally, it may be a short-term grid anomaly. The inverter will resume normal operation after detecting the grid is normal, requiring no manual intervention.</li> <li>2. If it occurs frequently, check if the grid voltage is within the allowable range. If not, contact the local power operator. If it is, also modify the grid undervoltage protection point after obtaining consent from the local power operator.</li> <li>3. If it cannot recover for a long time, check if the AC side circuit breaker and output cables are properly connected.</li> </ol>

Fault Code	Fault Name	Fault Cause	Troubleshooting Recommendation
F04	Grid Rapid Overvoltage Protection	Abnormal grid voltage detection or extremely high voltage triggers the fault.	<p>1. If it occurs occasionally, it may be a short-term grid anomaly. The inverter will resume normal operation after detecting the grid is normal, requiring no manual intervention.</p> <p>2. If it occurs frequently, check if the grid voltage is within the allowable range. If not, contact the local power operator. If it is, also modify the grid undervoltage protection point after obtaining consent from the local power operator.</p> <p>3. If it cannot recover for a long time, check if the AC side circuit breaker and output cables are properly connected.</p>
F05	10min Overvoltage Protection	The moving average of grid voltage within 10min exceeds the range specified by safety regulations.	Check if the grid voltage has been operating at a high level for a long time. If it occurs frequently, check if the grid frequency is within the allowable range. If not, contact the local power operator. If it is, also modify the grid 10min overvoltage protection point after obtaining consent from the local power operator.

Fault Code	Fault Name	Fault Cause	Troubleshooting Recommendation
F06	Grid Overfrequency	Grid anomaly: The actual grid frequency is higher than the local grid standard requirements.	<p>1. If it occurs occasionally, it may be a short-term grid anomaly. The inverter will resume normal operation after detecting the grid is normal, requiring no manual intervention.</p> <p>2. If it occurs frequently, check if the grid frequency is within the allowable range. If not, contact the local power operator. If it is, also modify the grid overfrequency protection point after obtaining consent from the local power operator.</p>
F07	Grid Underfrequency	Grid anomaly: The actual grid frequency is lower than the local grid standard requirements.	<p>1. If it occurs occasionally, it may be a short-term grid anomaly. The inverter will resume normal operation after detecting the grid is normal, requiring no manual intervention.</p> <p>2. If it occurs frequently, check if the grid frequency is within the allowable range. If not, contact the local power operator. If it is, also modify the grid overfrequency protection point after obtaining consent from the local power operator.</p>

Fault Code	Fault Name	Fault Cause	Troubleshooting Recommendation
F08	Grid Frequency Instability	Grid anomaly: The rate of change of the actual grid frequency does not comply with the local grid standard.	<p>1. If it occurs occasionally, it may be a short-term grid anomaly. The inverter will resume normal operation after detecting the grid is normal, requiring no manual intervention.</p> <p>2. If it occurs frequently, check if the grid frequency is within the allowable range. If not, contact the local power operator.</p>
F09	Anti-islanding Protection	The grid has been disconnected, but the grid voltage is maintained due to the presence of loads. Grid connection is stopped according to safety regulation protection requirements.	<p>1. If it occurs occasionally, it may be a short-term grid anomaly. The inverter will resume normal operation after detecting the grid is normal, requiring no manual intervention.</p> <p>2. If it occurs frequently, check if the grid frequency is within the allowable range. If not, contact the local power operator.</p>
F10	Voltage Ride-Through Undervoltage Fault	Grid anomaly: The duration of abnormal grid voltage exceeds the time specified by the high/low voltage ride-through requirements.	<p>1. If it occurs occasionally, it may be a short-term grid anomaly. The inverter will resume normal operation after detecting the grid is normal, requiring no manual intervention.</p> <p>2. If it occurs frequently, check if the grid voltage and frequency are within the allowable range and stable. If not, contact the local power operator.</p>

Fault Code	Fault Name	Fault Cause	Troubleshooting Recommendation
F11	HVRT Overvoltage	Grid anomaly: The duration of abnormal grid voltage exceeds the time specified by the high/low voltage ride-through requirements.	<p>1. If it occurs occasionally, it may be a short-term grid anomaly. The inverter will resume normal operation after detecting the grid is normal, requiring no manual intervention.</p> <p>2. If it occurs frequently, check if the grid voltage and frequency are within the allowable range and stable. If not, contact the local power operator.</p>
F12	30mA GFCI Protection	The input-to-ground insulation impedance becomes low during inverter operation.	<p>1. If it occurs occasionally, it may be caused by occasional external line anomalies. It will resume normal operation after the fault is cleared, requiring no manual intervention.</p> <p>2. If it occurs frequently or cannot recover for a long time, check if the PV string's impedance to ground is too low.</p>
F13	60mA GFCI Protection	The input-to-ground insulation impedance becomes low during inverter operation.	<p>1. If it occurs occasionally, it may be caused by occasional external line anomalies. It will resume normal operation after the fault is cleared, requiring no manual intervention.</p> <p>2. If it occurs frequently or cannot recover for a long time, check if the PV string's impedance to ground is too low.</p>

Fault Code	Fault Name	Fault Cause	Troubleshooting Recommendation
F14	150mA GFCI Protection	The input-to-ground insulation impedance becomes low during inverter operation.	<p>1. If it occurs occasionally, it may be caused by occasional external line anomalies. It will resume normal operation after the fault is cleared, requiring no manual intervention.</p> <p>2. If it occurs frequently or cannot recover for a long time, check if the PV string's impedance to ground is too low.</p>
F15	GFCI Gradual Change Protection	The input-to-ground insulation impedance becomes low during inverter operation.	<p>1. If it occurs occasionally, it may be caused by occasional external line anomalies. It will resume normal operation after the fault is cleared, requiring no manual intervention.</p> <p>2. If it occurs frequently or cannot recover for a long time, check if the PV string's impedance to ground is too low.</p>
F16	DCI Level 1 Protection	The DC component of the inverter's output current exceeds the safety regulations or the machine's default allowable range.	<p>1. If the abnormality is caused by an external fault, the inverter will automatically resume normal operation after the fault disappears, requiring no manual intervention.</p> <p>2. If this alarm occurs frequently, affecting the normal power generation of the power station, please contact the dealer or after-sales service center.</p>

Fault Code	Fault Name	Fault Cause	Troubleshooting Recommendation
F17	DCI Level 2 Protection	The DC component of the inverter's output current exceeds the safety regulations or the machine's default allowable range.	<p>1. If the abnormality is caused by an external fault, the inverter will automatically resume normal operation after the fault disappears, requiring no manual intervention.</p> <p>2. If this alarm occurs frequently, affecting the normal power generation of the power station, please contact the dealer or after-sales service center.</p>

Fault Code	Fault Name	Fault Cause	Troubleshooting Recommendation
F18	Low Insulation Resistance	<ol style="list-style-type: none"> <li>1. Photovoltaic string short-circuited to protective ground.</li> <li>2. The PV string is installed in a long-term humid environment with poor line-to-ground insulation.</li> <li>3. Low insulation resistance of the battery port line to ground.</li> </ol>	<ol style="list-style-type: none"> <li>1. Check the impedance of the PV string/battery port to protective ground. A value greater than 80kΩ is normal. If the measured value is less than 80kΩ, locate and rectify the short-circuit point.</li> <li>2. Check if the inverter's protective ground wire is correctly connected.</li> <li>3. If it is confirmed that the impedance is indeed below the default value in rainy weather, please reset the inverter's "Insulation Resistance Protection Point" via the App.</li> </ol> <p>For inverters in the Australian and New Zealand markets, insulation resistance faults can also be alerted in the following ways:</p> <ol style="list-style-type: none"> <li>1. The inverter is equipped with a buzzer. When a fault occurs, the buzzer sounds continuously for 1 minute; if the fault is not resolved, the buzzer sounds again every 30 minutes.</li> <li>2. If the inverter is added to the monitoring platform and the alarm notification method is set, alarm information can be sent to customers via email.</li> </ol>

Fault Code	Fault Name	Fault Cause	Troubleshooting Recommendation
F19	Grounding Abnormal	<p>1. The inverter's protective ground wire is not connected.</p> <p>2. When the PV string output is grounded, the inverter output side is not connected to an isolation transformer.</p>	<p>1. Please confirm whether the inverter's protective ground wire is properly connected.</p> <p>2. In scenarios where the PV string output is grounded, please confirm whether the inverter output side is connected to an isolation transformer.</p>
F20	Hard Anti-Backflow Protection	Load abnormal fluctuation	<p>1. If the abnormality is caused by an external fault, the inverter will automatically resume normal operation after the fault disappears, requiring no manual intervention.</p> <p>2. If this alarm occurs frequently, affecting the normal power generation of the power station, please contact the dealer or after-sales service center.</p>

Fault Code	Fault Name	Fault Cause	Troubleshooting Recommendation
F21	Internal Comm Loss	Sub DSP1 communication timeout - Main DSP, Sub DSP2 communication timeout - Main DSP, Sub DSP2 communication timeout - Sub DSP1, Main DSP communication timeout - Sub DSP1, Main DSP communication timeout - Sub DSP2, or Sub DSP1 communication timeout - Sub DSP2: 1. Chip not powered on 2. Chip program version error	Turn off the AC output side switch and the DC input side switch. After 5 minutes, turn on the AC output side switch and the DC input side switch. If the fault persists, please contact the dealer or after-sales service center.

Fault Code	Fault Name	Fault Cause	Troubleshooting Recommendation
		Main DSP can module error, Sub DSP1 can module error, or Sub DSP2 can module error: 1. Frame format error 2. Parity check error 3. can bus offline 4. Hardware CRC check error 5. Control bit is receive (transmit) during transmission (reception) 6. Transmission to a disallowed unit	
F22	Generator Waveform Detection Fault	1. This fault will be displayed continuously when no generator is connected. 2. When the generator is operating, failure to meet generator safety regulations will trigger this fault.	1. Ignore this fault if no generator is connected. 2. If this fault appears when the generator malfunctions, it is normal. After the generator recovers, wait for a period of time and the fault will be cleared automatically. 3. This fault does not affect the normal operation of off-grid mode. 4. When both the generator and the grid are connected and meet safety requirements, the grid has priority for grid connection, and the system will operate in grid-connected status.
F23	Generator Abnormal Connection		
F24	Generator Voltage Low		
F25	Generator Voltage High		
F26	Generator Frequency Low		

<b>Fault Code</b>	<b>Fault Name</b>	<b>Fault Cause</b>	<b>Troubleshooting Recommendation</b>
F27	Generator Frequency High		
F28	Parallel Unit I/O Self-Test Abnormal	Parallel communication cable not securely connected or parallel IO chip damaged	Check if the parallel communication cable is securely connected, then check if the IO chip is damaged. If so, replace the IO chip.
F29	Paralell Grid Line Reversed	Grid lines of some units are reversed with others	Reconnect the grid lines.
F30	AC HCT check Abnormal	Abnormal sampling detected in the AC sensor	Turn off the AC output side switch and the DC input side switch, wait for 5 minutes, then turn on the AC output side switch and the DC input side switch. If the fault persists, please contact the distributor or after-sales service center.
F31	GFCI HCT Check Abnormal	Abnormal sampling detected in the leakage current sensor	Turn off the AC output side switch and the DC input side switch, wait for 5 minutes, then turn on the AC output side switch and the DC input side switch. If the fault persists, please contact the distributor or after-sales service center.
F32	Inverter Internal Failure	Inverter failure detected	Turn off the AC output side switch and the DC input side switch, wait for 5 minutes, then turn on the AC output side switch and the DC input side switch. If the fault persists, please contact the distributor or after-sales service center.

Fault Code	Fault Name	Fault Cause	Troubleshooting Recommendation
F33	Flash Read/Write Error	Possible causes: Flash content changed; Flash lifespan exhausted;	1. Upgrade to the latest firmware. 2. Contact the distributor or after-sales service center.
F34	AFCI Check Failure	The arc fault module failed to detect an arc fault during the self-check process	Turn off the AC output side switch and the DC input side switch, wait for 5 minutes, then turn on the AC output side switch and the DC input side switch. If the fault persists, please contact the distributor or after-sales service center.
F35	Cabinet Overtemperature	Cabinet overtemperature. Possible causes: 1. Poor ventilation at the Inverter installation location. 2. Ambient overtemperature. 3. Internal fan malfunction.	1. Check if the ventilation at the Inverter installation location is adequate and if the ambient temperature exceeds the maximum allowable range. 2. If ventilation is poor or the ambient temperature is too high, improve the ventilation and heat dissipation conditions. 3. If both ventilation and ambient temperature are normal, contact the distributor or after-sales service center.

Fault Code	Fault Name	Fault Cause	Troubleshooting Recommendation
F36	Bus Overvoltage	BUS overvoltage. Possible causes: 1. PV voltage is too high; 2. Abnormal Inverter BUS voltage sampling; 3. Poor isolation of the dual-split transformer behind the Inverter, causing mutual interference when two inverters are grid-connected, resulting in a DC overvoltage alarm for one inverter during grid connection;	Turn off the AC output side switch and the DC input side switch, wait for 5 minutes, then turn on the AC output side switch and the DC input side switch. If the fault persists, please contact the distributor or after-sales service center.

Fault Code	Fault Name	Fault Cause	Troubleshooting Recommendation
F37	PV Input Overvoltage	<p>PV input voltage is too high. Possible cause:            Incorrect photovoltaic array configuration; too many solar panels connected in series per string, causing the string's open-circuit voltage to exceed the Inverter's maximum operating voltage.</p>	<p>Check the series configuration of the corresponding photovoltaic array string to ensure the string's open-circuit voltage does not exceed the Inverter's maximum operating voltage. The alarm will clear automatically once the photovoltaic array is correctly configured.</p>
F38	PV Sustained Hardware Overcurrent	<ol style="list-style-type: none"> <li>1. Unreasonable module configuration</li> <li>2. Hardware damage</li> </ol>	<p>Turn off the AC output side switch and the DC input side switch, wait for 5 minutes, then turn on the AC output side switch and the DC input side switch. If the fault persists, please contact the distributor or after-sales service center.</p>
F39	PV Sustained Software Overcurrent	<ol style="list-style-type: none"> <li>1. Unreasonable module configuration</li> <li>2. Hardware damage</li> </ol>	<p>Turn off the AC output side switch and the DC input side switch, wait for 5 minutes, then turn on the AC output side switch and the DC input side switch. If the fault persists, please contact the distributor or after-sales service center.</p>

<b>Fault Code</b>	<b>Fault Name</b>	<b>Fault Cause</b>	<b>Troubleshooting Recommendation</b>
F40, F98	String Reverse Connection (String 1-n) n: Determined based on the actual number of inverter strings	PV string reverse connection	Check if the string is reversely connected.

#### 8.5.2.2.2 Troubleshooting (Fault Codes F41-F80)

<b>Fault Code</b>	<b>Fault Name</b>	<b>Fault Cause</b>	<b>Recommended Handling</b>
F41	Generator Port Overload	<ol style="list-style-type: none"> <li>1. Off-grid side output exceeds the specifications.</li> <li>2. Short circuit on the off-grid side.</li> <li>3. Off-grid terminal voltage is too low.</li> <li>4. When used as a large load port, the large load exceeds the specifications.</li> </ol>	Confirm the off-grid side output voltage, current, power, and other data to identify the cause of the issue.

<b>Fault Code</b>	<b>Fault Name</b>	<b>Fault Cause</b>	<b>Recommended Handling</b>
F42	DC Arcing Failure (String 1-n) n: Determined based on the actual number of inverter strings.	<ol style="list-style-type: none"> <li>1. Loose DC side connection terminals.</li> <li>2. Poor contact at DC side connection terminals.</li> <li>3. Damaged DC cable cores causing poor contact.</li> </ol>	<ol style="list-style-type: none"> <li>1. After the unit reconnects to the grid, check if the voltage and current of each circuit abnormally decrease or become zero.</li> <li>2. Check if the DC side terminals are securely connected.</li> </ol>
F43	Grid Waveform Abnormal	Utility grid abnormality: Anomalies in grid voltage detection trigger the fault.	<ol style="list-style-type: none"> <li>1. If it occurs occasionally, it may be due to a short-term grid anomaly. The inverter will resume normal operation after detecting a normal grid, requiring no manual intervention.</li> <li>2. If it occurs frequently, please check if the grid voltage and frequency are within the allowable range and stable. If not, please contact the local power operator.</li> </ol>
F44	Grid Phase Loss	Utility grid abnormality: Single-phase voltage drop in the grid.	<ol style="list-style-type: none"> <li>1. If it occurs occasionally, it may be due to a short-term grid anomaly. The inverter will resume normal operation after detecting a normal grid, requiring no manual intervention.</li> <li>2. If it occurs frequently, please check if the grid voltage and frequency are within the allowable range and stable. If not, please contact the local power operator.</li> </ol>

<b>Fault Code</b>	<b>Fault Name</b>	<b>Fault Cause</b>	<b>Recommended Handling</b>
F45	Grid Voltage Imbalance	Excessive difference in grid phase voltages.	<p>1. If it occurs occasionally, it may be due to a short-term grid anomaly. The inverter will resume normal operation after detecting a normal grid, requiring no manual intervention.</p> <p>2. If it occurs frequently, please check if the grid voltage and frequency are within the allowable range and stable. If not, please contact the local power operator.</p>
F46	Grid Phase Sequence Failure	Inverter and grid wiring anomaly: Wiring is not in positive sequence.	<p>1. Check if the inverter and grid wiring are in positive sequence. The fault will automatically disappear after correct wiring (e.g., swapping any two live wires).</p> <p>2. If the fault persists despite correct wiring, please contact the dealer or after-sales service center.</p>
F47	Grid Rapid Shutdown Protection	Quickly shuts down output after detecting a grid power outage condition.	The fault automatically disappears after grid power supply is restored.
F48	Grid Neutral Wire Loss (Split Grid)	Neutral wire loss in a split-phase grid.	<p>1. The alarm automatically disappears after grid power supply is restored.</p> <p>2. Check if the AC line or AC switch is disconnected.</p>
F49	L-PE Short Circuit	Low impedance or short circuit between output phase line and PE.	Detect the impedance between the output phase line and PE, locate the position with low impedance and repair it.

<b>Fault Code</b>	<b>Fault Name</b>	<b>Fault Cause</b>	<b>Recommended Handling</b>
F50	DCV Level 1 Protection	Abnormal load fluctuation.	<p>1. If it is caused by an external fault, the inverter will automatically resume normal operation after the fault disappears, requiring no manual intervention.</p> <p>2. If this alarm occurs frequently and affects normal power generation of the plant, please contact the dealer or after-sales service center.</p>
F51	DCV Level 2 Protection	Abnormal load fluctuation.	
F52	Leakage Current (GFCI) Multiple Fault Shutdown	North American safety regulations require no automatic recovery after multiple faults; manual recovery or waiting 24h is required.	Please check if the PV string's impedance to ground is too low.
F53	DC Arcing (AFCI) Multiple Fault Shutdown	North American safety regulations require no automatic recovery after multiple faults; manual recovery or waiting 24h is required.	<p>1. After the unit reconnects to the grid, check if the voltage and current of each circuit abnormally decrease or become zero.</p> <p>2. Check if the DC side terminals are securely connected.</p>
F54	External Communication Link Broken	Inverter external device communication lost, possibly due to peripheral power supply issues, communication protocol mismatch, or unconfigured peripherals.	Determine based on the actual model and detection enable bits; peripherals not supported by certain models will not be detected.

<b>Fault Code</b>	<b>Fault Name</b>	<b>Fault Cause</b>	<b>Recommended Handling</b>
F55	Back-up Port Overload Fault	Prevents the inverter from continuously outputting overload.	Turn off some off-grid loads to reduce the inverter's off-grid output power.
F56	Back-up Port Overvoltage Fault	Prevents inverter output overvoltage from damaging loads.	1. If it occurs occasionally, it may be caused by load switching and requires no manual intervention. 2. If it occurs frequently, please contact the dealer or after-sales service center.
F57	External Box Fault	Waiting too long for the Box to switch relays during grid-to-off-grid transition.	1. Check if the Box is functioning normally. 2. Check if the Box communication wiring is correct.
F58	CT Loss Fault	CT connection wire disconnected (Japanese safety regulation requirement).	Check if the CT wiring is correct.
F59	Parallel Unit CAN Communication Abnormal	Parallel communication cables not securely connected or some units offline.	Check if all units are powered on and if the parallel communication cables are securely connected.
F60	Parallel Unit Back-up Connection Reversed	Some units' backup lines are connected in reverse with others.	Reconnect the backup lines.
F61	Inverter Soft Start Failure	Inverter soft start failure during off-grid cold start.	Check if the inverter module is damaged.

<b>Fault Code</b>	<b>Fault Name</b>	<b>Fault Cause</b>	<b>Recommended Handling</b>
F62	AC HCT Failure	HCT sensor abnormality exists.	Disconnect the AC output side switch and DC input side switch, wait 5 minutes, then close the AC output side switch and DC input side switch. If the fault persists, please contact the dealer or after-sales service center.
F63	GFCI HCT Failure	Leakage current sensor abnormality exists.	Disconnect the AC output side switch and DC input side switch, wait 5 minutes, then close the AC output side switch and DC input side switch. If the fault persists, please contact the dealer or after-sales service center.
F64	Inverter Internal Failure	Inverter fault exists.	Disconnect the AC output side switch and DC input side switch, wait 5 minutes, then close the AC output side switch and DC input side switch. If the fault persists, please contact the dealer or after-sales service center.
F65	AC Terminal Overtemperature	AC terminal temperature is too high. Possible causes: 1. Inverter installation location is not ventilated. 2. Ambient temperature is too high. 3. Internal fan operation is abnormal.	1. Check if the ventilation at the inverter installation location is adequate and if the ambient temperature exceeds the maximum allowable range. 2. If ventilation is poor or ambient temperature is too high, improve its ventilation and heat dissipation conditions. 3. If both ventilation and ambient temperature are normal, please contact the dealer or after-sales service center.

<b>Fault Code</b>	<b>Fault Name</b>	<b>Fault Cause</b>	<b>Recommended Handling</b>
F66	INV Module Overtemperature	<p>Inverter module temperature is too high. Possible causes:</p> <ol style="list-style-type: none"> <li>1. Inverter installation location is not ventilated.</li> <li>2. Ambient temperature is too high.</li> <li>3. Internal fan operation is abnormal.</li> </ol>	<ol style="list-style-type: none"> <li>1. Check if the ventilation at the inverter installation location is adequate and if the ambient temperature exceeds the maximum allowable range.</li> <li>2. If ventilation is poor or ambient temperature is too high, improve its ventilation and heat dissipation conditions.</li> <li>3. If both ventilation and ambient temperature are normal, please contact the dealer or after-sales service center.</li> </ol>
F67	Boost Module Overtemperature	<p>Boost module temperature is too high. Possible causes:</p> <ol style="list-style-type: none"> <li>1. Inverter installation location is not ventilated.</li> <li>2. Ambient temperature is too high.</li> <li>3. Internal fan operation is abnormal.</li> </ol>	<ol style="list-style-type: none"> <li>1. Check if the ventilation at the inverter installation location is adequate and if the ambient temperature exceeds the maximum allowable range.</li> <li>2. If ventilation is poor or ambient temperature is too high, improve its ventilation and heat dissipation conditions.</li> <li>3. If both ventilation and ambient temperature are normal, please contact the dealer or after-sales service center.</li> </ol>

<b>Fault Code</b>	<b>Fault Name</b>	<b>Fault Cause</b>	<b>Recommended Handling</b>
F68	AC Capacitor Overtemperature	Output filter capacitor temperature is too high. Possible causes: 1. Inverter installation location is not ventilated. 2. Ambient temperature is too high. 3. Internal fan operation is abnormal.	1. Check if the ventilation at the inverter installation location is adequate and if the ambient temperature exceeds the maximum allowable range. 2. If ventilation is poor or ambient temperature is too high, improve its ventilation and heat dissipation conditions. 3. If both ventilation and ambient temperature are normal, please contact the dealer or after-sales service center.
F69	PV IGBT Short Circuit Fault	Possible causes: 1. IGBT short circuit 2. Inverter sampling circuit abnormal	Disconnect the AC output side switch and DC input side switch, wait 5 minutes, then close the AC output side switch and DC input side switch. If the fault persists, please contact the dealer or after-sales service center.
F70	PV IGBT Open Circuit Fault	1. Software issue causing no PWM generation. 2. Drive circuit abnormal. 3. IGBT open circuit.	
F71	NTC Abnormal	NTC temperature sensor abnormality.	Disconnect the AC output side switch and DC input side switch, wait 5 minutes, then close the AC output side switch and DC input side switch. If the fault persists, please contact the dealer or after-sales service center.

<b>Fault Code</b>	<b>Fault Name</b>	<b>Fault Cause</b>	<b>Recommended Handling</b>
F72	PWM Abnormal	PWM abnormal waveform present.	Disconnect the AC output side switch and DC input side switch, wait 5 minutes, then close the AC output side switch and DC input side switch. If the fault persists, please contact the dealer or after-sales service center.
F73	CPU Interrupt Abnormal	CPU interrupt abnormality.	Disconnect the AC output side switch and DC input side switch, wait 5 minutes, then close the AC output side switch and DC input side switch. If the fault persists, please contact the dealer or after-sales service center.
F74	Microelectronics Fault	Functional safety detection abnormality.	Disconnect the AC output side switch and DC input side switch, wait 5 minutes, then close the AC output side switch and DC input side switch. If the fault persists, please contact the dealer or after-sales service center.
F75	PV HCT Fault	boost current sensor abnormal.	Disconnect the AC output side switch and DC input side switch, wait 5 minutes, then close the AC output side switch and DC input side switch. If the fault persists, please contact the dealer or after-sales service center.
F76	1.5V Reference Abnormal	Reference circuit fault.	Disconnect the AC output side switch and DC input side switch, wait 5 minutes, then close the AC output side switch and DC input side switch. If the fault persists, please contact the dealer or after-sales service center.
F77	0.3V Reference Abnormal	Reference circuit fault.	

<b>Fault Code</b>	<b>Fault Name</b>	<b>Fault Cause</b>	<b>Recommended Handling</b>
F78	CPLD Version Identification Error	CPLD version identification error.	Disconnect the AC output side switch and DC input side switch, wait 5 minutes, then close the AC output side switch and DC input side switch. If the fault persists, please contact the dealer or after-sales service center.
F79	CPLD Communication Fault	CPLD and DSP communication content error or timeout.	Disconnect the AC output side switch and DC input side switch, wait 5 minutes, then close the AC output side switch and DC input side switch. If the fault persists, please contact the dealer or after-sales service center.
F80	Model Identification Fault	Fault related to model identification error.	Disconnect the AC output side switch and DC input side switch, wait 5 minutes, then close the AC output side switch and DC input side switch. If the fault persists, please contact the dealer or after-sales service center.

#### 8.5.2.2.3 Troubleshooting (Fault Codes F81-F121)

<b>Fault Code</b>	<b>Fault Name</b>	<b>Possible Causes</b>	<b>Recommended Troubleshooting</b>
F81	P-Bus Overvoltage		Disconnect the AC output side switch and the DC input side switch, close them again after 5 minutes. If the fault persists, please contact the dealer or after-sales service center.

Fault Code	Fault Name	Possible Causes	Recommended Troubleshooting
F82	N-Bus Overvoltage	BUS overvoltage, possible causes: 1. PV voltage is too high; 2. Inverter BUS voltage sampling is abnormal; 3. Poor isolation of the dual-split transformer at the inverter's output leads to mutual interference when two inverters are grid-connected, causing one inverter to report a DC overvoltage during grid connection;	
F83	Bus Overvoltage (Sub CPU1)		Disconnect the AC output side switch and the DC input side switch, close them again after 5 minutes. If the fault persists, please contact the dealer or after-sales service center.
F84	P-Bus Overvoltage (Sub CPU1)		

Fault Code	Fault Name	Possible Causes	Recommended Troubleshooting
F85	N-Bus Overvoltage (Sub CPU1)	BUS overvoltage, possible causes: 1. PV voltage is too high; 2. Inverter BUS voltage sampling is abnormal; 3. Poor isolation of the dual-split transformer at the inverter's output leads to mutual interference when two inverters are grid-connected, causing one inverter to report a DC overvoltage during grid connection;	
F86	Bus Overvoltage (Sub CPU2)		Disconnect the AC output side switch and the DC input side switch, close them again after 5 minutes. If the fault persists, please contact the dealer or after-sales service center.
F87	P-Bus Overvoltage (Sub CPU2)		

Fault Code	Fault Name	Possible Causes	Recommended Troubleshooting
F88	N-Bus Overvoltage (Sub CPU2)	BUS overvoltage, possible causes: 1. PV voltage is too high; 2. Inverter BUS voltage sampling is abnormal; 3. Poor isolation of the dual-split transformer at the inverter's output leads to mutual interference when two inverters are grid-connected, causing one inverter to report a DC overvoltage during grid connection;	
F89	P-Bus Overvoltage (CPLD)		Disconnect the AC output side switch and the DC input side switch, close them again after 5 minutes. If the fault persists, please contact the dealer or after-sales service center.

Fault Code	Fault Name	Possible Causes	Recommended Troubleshooting
F90	N-Bus Overvoltage(CPLD)	BUS overvoltage, possible causes: 1. PV voltage is too high; 2. Inverter BUS voltage sampling is abnormal; 3. Poor isolation of the dual-split transformer at the inverter's output leads to mutual interference when two inverters are grid-connected, causing one inverter to report a DC overvoltage during grid connection;	
F91	FlyCap Software Overvoltage	FlyCap overvoltage, possible causes: 1. PV voltage is too high;	Disconnect the AC output side switch and the DC input side switch, close them again after 5 minutes. If the fault persists, please contact the dealer or after-sales service center.
F92	FlyCap Hardware Overvoltage	2. Inverter fly-capacitor voltage sampling is abnormal;	

Fault Code	Fault Name	Possible Causes	Recommended Troubleshooting
F93	FlyCap Undervoltage	FlyCap undervoltage, possible causes: 1. PV energy is insufficient; 2. Inverter fly-capacitor voltage sampling is abnormal;	Disconnect the AC output side switch and the DC input side switch, close them again after 5 minutes. If the fault persists, please contact the dealer or after-sales service center
F94	FlyCap Precharge Failure	FlyCap precharge failure, possible causes: 1. PV energy is insufficient; 2. Inverter fly-capacitor voltage sampling is abnormal;	Disconnect the AC output side switch and the DC input side switch, close them again after 5 minutes. If the fault persists, please contact the dealer or after-sales service center
F95	FlyCap Precharge Abnormal	1. Control loop parameters are unreasonable 2. Hardware damage	Disconnect the AC output side switch and the DC input side switch, close them again after 5 minutes. If the fault persists, please contact the dealer or after-sales service center
F96, F97	String Overcurrent (String 1-n) n: Determined by the actual number of inverter strings	Possible Causes: 1. String overcurrent; 2. String current sensor abnormality	Disconnect the AC output side switch and DC input side switch, close them after 5 minutes. If the fault persists, please contact the distributor or after-sales service center.

<b>Fault Code</b>	<b>Fault Name</b>	<b>Possible Causes</b>	<b>Recommended Troubleshooting</b>
F99, F100	String Loss (String 1-n) n: Determined by the actual number of inverter strings	String fuse disconnected (if present)	Check if the fuse is disconnected.
F101	Battery 1 Precharge fault	Battery 1 precharge circuit fault (precharge resistor burned out, etc.)	Check if the precharge circuit is in good condition. Check if the battery voltage matches the bus voltage after the battery is powered on. If not, please contact the distributor or after-sales service center.
F102	Battery 1 Relay Failure	Battery 1 relay cannot operate normally	After the battery is powered on, check if the battery relay is working, listen for a closing sound. If it does not operate, please contact the distributor or after-sales service center.
F103	Battery 1 Connection Overvoltage	Battery 1 connection voltage exceeds the machine's rated range	Confirm if the battery voltage is within the machine's rated range.
F104	Battery 2 Precharge fault	Battery 2 precharge circuit fault (precharge resistor burned out, etc.)	Check if the precharge circuit is in good condition. Check if the battery voltage matches the bus voltage after the battery is powered on. If not, please contact the distributor or after-sales service center.

<b>Fault Code</b>	<b>Fault Name</b>	<b>Possible Causes</b>	<b>Recommended Troubleshooting</b>
F105	Battery 2 Relay Failure	Battery 2 relay cannot operate normally	After the battery is powered on, check if the battery relay is working, listen for a closing sound. If it does not operate, please contact the distributor or after-sales service center.
F106	Battery 2 Connection Overvoltage	Battery 2 connection voltage exceeds the machine's rated range	Confirm if the battery voltage is within the machine's rated range.
F107	On-grid PWM Sync Failure	Abnormality occurred during carrier synchronization for grid connection	<ol style="list-style-type: none"> <li>1. Check if the synchronization cable connection is normal.</li> <li>2. Check if the master/slave settings are normal;</li> <li>3. Disconnect the AC output side switch and DC input side switch, close them after 5 minutes. If the fault persists, please contact the distributor or after-sales service center.</li> </ol>
F108	DSP Communication fault	-	-
F109	External STS fault	Inverter and STS connecting cable abnormality	Check if the wiring sequence of the harness between the inverter and the STS corresponds one-to-one in order.

<b>Fault Code</b>	<b>Fault Name</b>	<b>Possible Causes</b>	<b>Recommended Troubleshooting</b>
F110	Export Limit Protection	<ol style="list-style-type: none"> <li>1. Inverter reports error and disconnects from grid</li> <li>2. meter communication is unstable</li> <li>3. Reverse power flow condition occurs</li> </ol>	<ol style="list-style-type: none"> <li>1. Check if the inverter has other error messages. If yes, handle them accordingly;</li> <li>2. Check if the meter connection is reliable;</li> <li>3. If this alarm occurs frequently, affecting normal power plant generation, please contact the distributor or after-sales service center.</li> </ol>
F111	Bypass Overload	-	-
F112	Black Start Failure	-	-
F113	Offgrid AC Ins Volt High	-	-
F114	Relay Failure <sup>2</sup>	<p>Relay abnormality, causes:</p> <ol style="list-style-type: none"> <li>1. Relay abnormality (relay short circuit)</li> <li>2. Relay sampling circuit abnormality.</li> <li>3. Abnormal AC side wiring (may have loose connection or short circuit)</li> </ol>	<p>Turn off the AC output side switch and the DC input side switch. After 5 minutes, turn on the AC output side switch and the DC input side switch. If the fault persists, please contact the dealer or after-sales service center.</p>
F115	SVG Precharge Disabled	SVG precharge hardware failure	Contact the dealer or after-sales service center.

<b>Fault Code</b>	<b>Fault Name</b>	<b>Possible Causes</b>	<b>Recommended Troubleshooting</b>
F116	Nighttime SVG PID Prevention Fault	PID prevention hardware abnormality	
F117	DSP Version Identification Error	DSP software version identification error	Turn off the AC output side switch and the DC input side switch. After 5 minutes, turn on the AC output side switch and the DC input side switch. If the fault persists, please contact the dealer or after-sales service center.
F118	MOS Continuous Overvoltage	<ol style="list-style-type: none"> <li>1. Software issue causing inverter drive to turn off earlier than flyback drive;</li> <li>2. Inverter drive circuit abnormality preventing turn-on;</li> <li>3. PV voltage too high;</li> <li>4. Mos voltage sampling abnormality;</li> </ol>	Turn off the AC output side switch and the DC input side switch. After 5 minutes, turn on the AC output side switch and the DC input side switch. If the fault persists, please contact the dealer or after-sales service center.
F119	Busbar Short Circuit Fault	Hardware damage	If the inverter remains off-grid after a BUS short circuit fault occurs, please contact the dealer or after-sales service center.

Fault Code	Fault Name	Possible Causes	Recommended Troubleshooting
F120	Busbar Sampling Abnormality	1. BUS voltage sampling hardware fault	Turn off the AC output side switch and the DC input side switch. After 5 minutes, turn on the AC output side switch and the DC input side switch. If the fault persists, please contact the dealer or after-sales service center.
F121	DC Side Sampling Abnormality	1. BUS voltage sampling hardware fault 2. Battery voltage sampling hardware fault 3. Dcrly Relay Failure	Turn off the AC output side switch and the DC input side switch. After 5 minutes, turn on the AC output side switch and the DC input side switch. If the fault persists, please contact the dealer or after-sales service center.

Fault Code	Fault Name	Possible Causes	Recommended Troubleshooting
F122	PV Access Mode Setting Error	<p>PV Access Mode has three modes, taking four MPPT channels as an example:</p> <ol style="list-style-type: none"> <li>1. Parallel Mode: i.e., AAAA mode (same-source mode), PV1-PV4 are same-source, the 4 PV channels connect to the same solar panel</li> <li>2. Partial Parallel Mode: i.e., AACC mode, PV1 and PV2 are same-source connected, PV3 and PV4 are same-source connected</li> <li>3. Independent Mode: i.e., ABCD mode (non-same-source), PV1, PV2, PV3, PV4 connect independently, the 4 PV channels each connect to one solar panel</li> </ol> <p>If the actual PV Access Mode does not match the PV Access Mode set in the device, this fault</p>	<p>Check if the PV Access Mode is set correctly (ABCD, AACC, AAAA), and reset the PV Access Mode according to the correct method.</p> <ol style="list-style-type: none"> <li>1. Confirm that each connected PV channel is correctly wired;</li> <li>2. If the PV is correctly wired, check via the APP or screen whether the currently set "PV Access Mode" corresponds to the actual access mode;</li> <li>3. If the currently set "PV Access Mode" does not match the actual access mode, use the APP or screen to set the "PV Access Mode" to the mode consistent with the actual situation. After setting, disconnect the PV and AC power supply and restart;</li> <li>4. After setting, if the current "PV Access Mode" matches the actual access mode but the fault still occurs, please contact the dealer or after-sales service center.</li> </ol>

<b>Fault Code</b>	<b>Fault Name</b>	<b>Possible Causes</b>	<b>Recommended Troubleshooting</b>
		will be reported.	

#### 8.5.2.2.4 Troubleshooting (Fault Codes F122-F163)

<b>Fault Code</b>	<b>Fault Name</b>	<b>Fault Cause</b>	<b>Recommended Troubleshooting</b>
F123	Multi-channel PV Phase Error	PV Input Mode Setting Error	<p>Check if the PV Access Mode is correctly set (ABCD, AACC, AAAA), and reset the PV Access Mode correctly.</p> <ol style="list-style-type: none"> <li>1. Confirm that each channel of PV is correctly connected;</li> <li>2. If the PV is correctly connected, check via the APP or screen whether the currently set "PV Access Mode" corresponds to the actual connection mode;</li> <li>3. If the currently set "PV Access Mode" does not match the actual connection mode, use the APP or screen to set the "PV Access Mode" to match the actual situation. After setting, disconnect and restart the PV and AC power supply;</li> <li>4. After setting, if the current "PV Access Mode" matches the actual connection mode but this fault still occurs, please contact the distributor or after-sales service center.</li> </ol>

<b>Fault Code</b>	<b>Fault Name</b>	<b>Fault Cause</b>	<b>Recommended Troubleshooting</b>
F124	Battery 1 Reverse Connection fault	Battery 1 Positive and Negative Poles Reversed	Check if the polarity of the battery and the machine terminals is consistent.
F125	Battery 2 Reverse Connection fault	Battery 2 Positive and Negative Poles Reversed	Check if the polarity of the battery and the machine terminals is consistent.
F126	Abnormal Battery Connection	Abnormal Battery Connection	Check if the battery is working normally.
F127	BAT Overtemperature	Battery temperature is too high, possible reasons: 1. Inverter installation location is not ventilated. 2. Ambient temperature is too high. 3. Internal fan operation is abnormal.	Disconnect the AC output side switch and DC input side switch, wait for 5 minutes, then close the AC output side switch and DC input side switch. If the fault persists, please contact the distributor or after-sales service center.
F128	Ref Voltage Abnormal	Reference circuit fault	Disconnect the AC output side switch and DC input side switch, wait for 5 minutes, then close the AC output side switch and DC input side switch. If the fault persists, please contact the distributor or after-sales service center.

<b>Fault Code</b>	<b>Fault Name</b>	<b>Fault Cause</b>	<b>Recommended Troubleshooting</b>
F129	Cabinet Under Temperature	Cabinet temperature is too low, possible reason: ambient temperature is too low.	Disconnect the AC output side switch and DC input side switch, wait for 5 minutes, then close the AC output side switch and DC input side switch. If the fault persists, please contact the distributor or after-sales service center.
F130	AC Side SPD fault	AC Side Surge Protective Device Failure	Replace the AC side surge protective device.
F131	DC Side SPD fault	DC Side Surge Protective Device Failure	Replace the DC side surge protective device.
F132	Internal Fan Abnormal	Internal fan abnormal, possible reasons: 1. Fan power supply abnormal; 2. Mechanical fault (stall); 3. Fan aging or damage.	Disconnect the AC output side switch and DC input side switch, wait for 5 minutes, then close the AC output side switch and DC input side switch. If the fault persists, please contact the distributor or after-sales service center.
F133	External Fan Abnormal	External fan abnormal, possible reasons: 1. Fan power supply abnormal; 2. Mechanical fault (stall); 3. Fan aging or damage.	

Fault Code	Fault Name	Fault Cause	Recommended Troubleshooting
F134	PID Diagnosis Abnormal	PID hardware fault or PV voltage too high causing PID pause	PID pause warning caused by high PV voltage requires no action. PID hardware fault can be cleared by turning the PID switch off and then on. Replace the PID device.
F135	Trip-Switch Trip Warning	Possible reasons: Overcurrent or PV reverse connection caused the trip switch to open;	Contact the distributor or after-sales service center; The reason for tripping is PV short circuit or reverse connection. Check if there is a historical PV short circuit warning or historical PV reverse connection warning. If present, maintenance personnel need to check the corresponding PV condition. After checking and confirming no fault, the trip switch can be manually closed, and this warning can be cleared via the APP interface by clearing historical faults.
F136	Historical PV IGBT Short Circuit Warning	Possible reasons: Overcurrent caused the trip switch to open;	Contact the distributor or after-sales service center; Maintenance personnel need to check the Boost hardware and external string for faults according to the historical PV short circuit warning subcode. After checking and confirming no fault, this warning can be cleared via the APP interface by clearing historical faults.

<b>Fault Code</b>	<b>Fault Name</b>	<b>Fault Cause</b>	<b>Recommended Troubleshooting</b>
F137 , F138	Historical PV Reverse Connection Warning (String 1-n) (n: determined by the actual number of inverter strings)	Possible reasons: PV reverse connection caused the trip switch to open;	Contact the distributor or after-sales service center; Maintenance personnel need to check the corresponding string for reverse connection according to the historical PV reverse connection warning subcode, and check if there is a voltage difference in the PV panel configuration. After checking and confirming no fault, this warning can be cleared via the APP interface by clearing historical faults.
F139	Flash Read/Write Error Warning	Possible reasons: 1. Flash content changed; 2. Flash lifespan exhausted;	1. Upgrade to the latest program version; 2. Contact the distributor or after-sales service center.
F140	Meter Comm Loss	This warning may only occur after anti-backflow function is enabled. Possible reasons: 1. Meter not connected; 2. Communication cable connection between meter and inverter is incorrect.	Check the meter wiring, connect the meter correctly. If the fault persists after checking, please contact the distributor or after-sales service center.
F141	PV Panel Type Identification Failure	PV panel identification hardware abnormal	Contact the distributor or after-sales service center.

<b>Fault Code</b>	<b>Fault Name</b>	<b>Fault Cause</b>	<b>Recommended Troubleshooting</b>
F142	PV String Mismatch	PV string mismatch, two strings under the same MPPT have different open-circuit voltage configurations	Check the open-circuit voltage of the two strings, configure strings with the same open-circuit voltage under the same MPPT. Prolonged string mismatch poses a safety hazard.
F143	CT Not Connected	CT Not Connected	Check the CT wiring.
F144	CT Reverse Connection	CT Reverse Connection	Check the CT wiring.
F145	PE Loss	Ground wire not connected	Check the ground wire.
F146	String Terminal High Temperature (String 1~8)	Register 37176 PV Terminal Temperature Warning Subcode 1 is set	-
F147	String Terminal High Temperature (String 9~16)	Register 37177 PV Terminal Temperature Warning Subcode 2 is set	-
F148	String Terminal High Temperature (String 17~20)	Register 37178 PV Terminal Temperature Warning Subcode 3 is set	-

<b>Fault Code</b>	<b>Fault Name</b>	<b>Fault Cause</b>	<b>Recommended Troubleshooting</b>
F149	Historical PV Reverse Connection Warning (String 33~48)	Possible reasons: PV reverse connection caused the trip switch to open;	Contact the distributor or after-sales service center; Maintenance personnel need to check the corresponding string for reverse connection according to the historical PV reverse connection warning subcode, and check if there is a voltage difference in the PV panel configuration. After checking and confirming no fault, this warning can be cleared via the APP interface by clearing historical faults.
F150	Battery 1 Low Voltage	Battery voltage below set value	-
F151	Battery 2 Low Voltage	Battery voltage below set value	-
F152	Low Voltage of Battery Power	Battery in non-charging mode, voltage below shutdown voltage	-
F153	Battery 1 High Voltage	-	-
F154	Battery 2 High Voltage	-	-

<b>Fault Code</b>	<b>Fault Name</b>	<b>Fault Cause</b>	<b>Recommended Troubleshooting</b>
F155	Online Low Insulation Resistance	<p>1. Photovoltaic string short-circuited to protective earth.</p> <p>2. Photovoltaic string installed in a long-term humid environment with poor line-to-ground insulation.</p>	<p>1. Check the impedance of the photovoltaic string to protective earth. If a short circuit is found, rectify the short circuit point.</p> <p>2. Check if the inverter's protective earth wire is correctly connected.</p> <p>3. If it is confirmed that the impedance is indeed below the default value in rainy weather, please reset the "Insulation Resistance Protection Point".</p>
F156	Micro-grid Overload Warning	backup terminal input current too high	Occasional occurrence requires no action; if this warning appears frequently, please contact the distributor or after-sales service center.
F157	Manual Reset	-	-
F158	Generator Phase Sequence Abnormal	-	-
F159	Multiplexed Port Configuration Abnormal	Multiplexed (Generator) port configured as microgrid or large load, but a generator is actually connected	Use the APP to change the multiplexed (Generator) port configuration.
F160	EMS Forced Off-grid	EMS issued forced off-grid command, but off-grid function is not enabled	Enable the off-grid function.

<b>Fault Code</b>	<b>Fault Name</b>	<b>Fault Cause</b>	<b>Recommended Troubleshooting</b>
F161	Passive Anti-islanding Protection	-	-
F162	Grid Type Fault	Actual grid type (two-phase or split-phase) does not match the set safety standard	Switch to the corresponding safety standard according to the actual grid type.
F163	Grid Phase Instability	Grid abnormality: Grid voltage phase change rate does not comply with local grid standards.	<p>1. If it occurs occasionally, it may be a temporary grid abnormality. The inverter will resume normal operation after detecting a normal grid, requiring no manual intervention.</p> <p>2. If it occurs frequently, check if the grid frequency is within the allowable range. If not, please contact the local power operator.</p>

#### 8.5.2.2.5 Fault Symptom Handling

Fault Name	Fault Cause	Troubleshooting Suggestion
Generator Failure	<ol style="list-style-type: none"> <li>1. This fault will be displayed continuously when a generator is not connected.</li> <li>2. During generator operation, failure to meet generator safety regulations will trigger this fault.</li> </ol>	<ol style="list-style-type: none"> <li>1. If no generator is connected, ignore this fault.</li> <li>2. If this fault appears when the generator has a fault, this is normal. Wait for a period after the generator recovers, and the fault will clear automatically.</li> <li>3. This fault does not affect the normal operation of off-grid mode.</li> <li>4. When both the generator and the grid are connected and meet safety requirements, the grid has priority for grid connection, and the system will operate in grid-connected mode.</li> </ol>
BMS Status Bit Error	BMS module failure	Turn off the AC output side switch and the DC input side switch. After 5 minutes, turn on the AC output side switch and the DC input side switch. If the fault persists, please contact the distributor or after-sales service center.
Ambient Overtemperature	<ol style="list-style-type: none"> <li>1. Poor machine ventilation</li> <li>2. Hot air flows back to the ambient temperature sampling point</li> </ol>	Turn off the AC output side switch and the DC input side switch. After 5 minutes, turn on the AC output side switch and the DC input side switch. If the fault persists, please contact the distributor or after-sales service center.

Fault Name	Fault Cause	Troubleshooting Suggestion
PV Terminal Overtemperature	PV terminal overtemperature, possible causes: 1. Poor ventilation at the inverter installation location. 2. Ambient temperature is too high. 3. Internal fan operation is abnormal.	1. Check if the ventilation at the inverter installation location is adequate and if the ambient temperature exceeds the maximum allowable range. 2. If ventilation is poor or the ambient temperature is too high, please improve the ventilation and heat dissipation conditions. 3. If both ventilation and ambient temperature are normal, please contact the distributor or after-sales service center.
BAT Terminal Overtemperature	BAT terminal overtemperature, possible causes: 1. Poor ventilation at the inverter installation location. 2. Ambient temperature is too high.	1. Check if the ventilation at the inverter installation location is adequate and if the ambient temperature exceeds the maximum allowable range.
AC Terminal Overtemperature Warning	AC terminal overtemperature, possible causes: 1. Poor ventilation at the inverter installation location. 2. Ambient temperature is too high. 3. Internal fan operation is abnormal.	2. If ventilation is poor or the ambient temperature is too high, please improve the ventilation and heat dissipation conditions. 3. If both ventilation and ambient temperature are normal, please contact the distributor or after-sales service center.

<b>Fault Name</b>	<b>Fault Cause</b>	<b>Troubleshooting Suggestion</b>
BAT Terminal Overtemperature Warning	BAT terminal overtemperature, possible causes: 1. Poor ventilation at the inverter installation location. 2. Ambient temperature is too high.	1. Check if the ventilation at the inverter installation location is adequate and if the ambient temperature exceeds the maximum allowable range. 2. If ventilation is poor or the ambient temperature is too high, please improve the ventilation and heat dissipation conditions. 3. If both ventilation and ambient temperature are normal, please contact the distributor or after-sales service center.
Three-phase on-grid fault	Three-phase external wiring error	Re-wire the connections.
External STS Failure	Abnormal cable connection between the inverter and the STS	Check if the wiring sequence of the harness between the inverter and the STS corresponds correctly one by one.

<b>Fault Name</b>	<b>Fault Cause</b>	<b>Troubleshooting Suggestions</b>
Parallel Comm Timeout Shutdown	In parallel operation, if a slave unit has not communicated with the master for over 400 seconds	Check if the parallel communication cable harness is securely connected. Check for duplicate slave addresses.
Three-phase off-grid phase loss fault	Phase loss in a three-phase system	1. Check if all inverters are powered on; 2. Check if each phase of the three-phase system is connected to an inverter;

Fault Name	Fault Cause	Troubleshooting Suggestions
EPO	External hardware emergency stop button triggered or remote emergency stop command triggered	<ol style="list-style-type: none"> <li>1. If it was triggered remotely intentionally, it can be ignored;</li> <li>2. If not triggered intentionally, please contact the dealer or after-sales service center.</li> </ol>
High Combustible Gas Concentration	Automatically triggered when a combustible gas device detects a concentration of 20% LEL or higher	<ol style="list-style-type: none"> <li>1. After the fault occurs, the unit will automatically open the air damper to exhaust and reduce the concentration. The fault will automatically clear if the concentration remains below 5% LEL for 15 minutes.</li> <li>2. If a cluster-level fire protection fault is triggered after the fault occurs, the air damper will automatically close. Confirm the damper status within 30s to ensure the cluster-level fire protection operates in a sealed space.</li> <li>3. Please contact the dealer or after-sales service center.</li> </ol>
Combustible Gas Device Air Damper Open Signal Mismatch with Feedback	Mismatch between the control signal to open the air damper and the feedback signal	<ol style="list-style-type: none"> <li>1. Check the cable harness signal connection for issues.</li> <li>2. Please contact the dealer or after-sales service center.</li> </ol>
One-Key Shutdown	Check via the App if the one-key shutdown function is enabled	Disable the one-key shutdown.

Fault Name	Fault Cause	Troubleshooting Suggestions
Offline Shutdown	-	-
Remote Shutdown	-	-
On-Grid SPD Fault	-	<ol style="list-style-type: none"> <li>1. Try restarting the unit and observe if the fault clears;</li> <li>2. If the fault persists after restart, please contact the dealer or after-sales service center.</li> </ol>
Off-Grid SPD Fault	-	<ol style="list-style-type: none"> <li>1. Try restarting the unit and observe if the fault clears;</li> <li>2. If the fault persists after restart, please contact the dealer or after-sales service center.</li> </ol>
Child Node Communication Failure	Internal communication abnormal	<ol style="list-style-type: none"> <li>1. Try restarting the unit and observe if the fault clears;</li> <li>2. If the fault persists after restart, please contact the dealer or after-sales service center.</li> </ol>
Dehumidifier Communication Fault	Communication link abnormal between the dehumidifier and the LC control box	<ol style="list-style-type: none"> <li>1. Check the communication cable harness and observe if the fault clears;</li> <li>2. Try restarting the unit and observe if the fault clears;</li> <li>3. If the fault persists after restart, please contact the dealer or after-sales service center.</li> </ol>

Fault Name	Fault Cause	Troubleshooting Suggestions
Combustible Gas Detection Device Communication Fault	<ol style="list-style-type: none"> <li>1. The combustible gas device was not properly configured with the 485 address set to 2 during factory setup.</li> <li>2. Communication link abnormal between the combustible gas device and the LC control box</li> </ol>	<ol style="list-style-type: none"> <li>1. Check the communication cable harness and observe if the fault clears;</li> <li>2. Try restarting the unit and observe if the fault clears;</li> <li>3. Use the method provided by the combustible gas device manufacturer to check if the device address is 2. If not, modify it;</li> <li>4. If the fault persists after restart, please contact the dealer or after-sales service center.</li> </ol>
DG Communication Failure	Communication link abnormal between the control board and the diesel generator	<ol style="list-style-type: none"> <li>1. Check the communication cable harness and observe if the fault clears;</li> <li>2. Try restarting the unit and observe if the fault clears;</li> <li>3. If the fault persists after restart, please contact the dealer or after-sales service center.</li> </ol>
Battery Over Voltage	<ol style="list-style-type: none"> <li>1. Single cell voltage too high</li> <li>2. Voltage sensing line abnormal</li> </ol>	Record the fault phenomenon, restart the battery, wait a few minutes, and confirm if the fault disappears. If the problem persists after restart, please contact the after-sales service center.
Battery Undervoltage	<ol style="list-style-type: none"> <li>1. Total battery voltage too high</li> <li>2. Voltage sensing line abnormal</li> </ol>	
	<ol style="list-style-type: none"> <li>1. Single cell voltage too low</li> <li>2. Voltage sensing line abnormal</li> </ol>	

Fault Name	Fault Cause	Troubleshooting Suggestions
	1. Total battery voltage too low 2. Voltage sensing line abnormal	
Battery Overcurrent	1. Charging current too high, battery current limiting abnormal: sudden changes in temperature and voltage values 2. Inverter response abnormal	
	Battery discharge current too high	
Battery Overtemperature	1. Ambient temperature too high 2. Temperature sensor abnormal	
Battery Undertemperature	1. Ambient temperature too low 2. Temperature sensor abnormal	
Battery Terminal Overtemperature	Terminal temperature too high	

Fault Name	Fault Cause	Troubleshooting Suggestions
Battery Imbalance	<p>1. Excessive temperature difference At different stages, the battery will limit the battery power, i.e., limit the charge/discharge current. Therefore, this issue is generally difficult to occur.</p> <p>2. Cell capacity degradation leads to excessive internal resistance, causing large temperature rise during overcurrent and thus large temperature difference.</p> <p>3. Poor welding of cell tabs leads to rapid cell temperature rise during overcurrent.</p> <p>4. Temperature sampling issue;</p> <p>5. Power cable connection loose</p>	

Fault Name	Fault Cause	Troubleshooting Suggestions
	1. Inconsistent cell aging levels 2. Slave board chip issues can also cause excessive cell voltage difference; 3. Slave board balancing issues can also cause excessive cell voltage difference 4. Caused by wiring harness issues	
Insulation Resistance	Insulation resistance damaged	Check if the ground wire is properly connected, restart the battery. If the problem persists after restart, please contact the after-sales service center.
Pre-charging Failure	Pre-charging failure	Indicates that during the pre-charging process, the voltage across the pre-charge MOS always exceeds the specified threshold. Power off and restart, then observe if this fault persists. Check if the wiring is correct and if the pre-charge MOS is damaged.
Sensing Line Fault	Battery sensing line poor contact or disconnected	Check the wiring, restart the battery. If the problem persists after restart, please contact the after-sales service center.
	Cell voltage sensing line poor contact or disconnected	

Fault Name	Fault Cause	Troubleshooting Suggestions
	Cell temperature sensing line poor contact or disconnected	Check the wiring, restart the battery. If the problem persists after restart, please contact the after-sales service center.
	Dual-channel current comparison error too large, or current sensing line loop abnormal	
	Dual-channel voltage comparison error too large or MCU and AFE voltage comparison error too large, or voltage sensing line loop abnormal	
	Temperature sensing line loop abnormal or poor contact, disconnected	
	Overvoltage level 5 or overtemperature level 5, tripped three-terminal fuse	The three-terminal fuse is blown. Please contact the after-sales service center to replace the main control board.
Relay or MOS Overtemperature	Relay or MOS overtemperature	This fault indicates the MOS transistor temperature exceeds the specified threshold. Power off and let it sit for 2 hours for the temperature to recover.

Fault Name	Fault Cause	Troubleshooting Suggestions
Shunt Overtemperature	Shunt overtemperature	This fault indicates the shunt temperature exceeds the specified threshold. Power off and let it sit for 2 hours for the temperature to recover.
BMS1 Other Fault 1 (Residential Storage)	Relay or MOS Open Circuit	<ol style="list-style-type: none"> <li>1. Upgrade the software, power off and let it sit for 5 minutes, then restart to see if the fault persists;</li> <li>2. If it persists, replace the battery pack</li> </ol>
	Relay or MOS Short Circuit	<ol style="list-style-type: none"> <li>1. Upgrade the software, power off and let it sit for 5 minutes, then restart to see if the fault persists;</li> <li>2. If it persists, replace the battery pack</li> </ol>
	Communication abnormal between master cluster and slave clusters, or cell inconsistency between clusters	<ol style="list-style-type: none"> <li>1. Check the battery information and software version of the slave unit, and if the communication cable connection to the master unit is normal</li> <li>2. Upgrade the software</li> </ol>
	Battery system loop wiring harness abnormal, causing the interlock signal not to form a loop	Check if the terminal resistor is installed correctly
	BMS and PCS communication abnormal	<ol style="list-style-type: none"> <li>1. Confirm if the communication cable interface definitions between the inverter and the connected battery are correct;</li> <li>2. Please contact the after-sales service center to check backend data and observe if the inverter and battery software match correctly.</li> </ol>

Fault Name	Fault Cause	Troubleshooting Suggestions
	BMS master control and slave control communication cable harness abnormal	1. Check the wiring and restart the battery; 2. Upgrade the battery software. If the problem persists after restart, please contact the after-sales service center.
	Communication lost between main negative chips	
	Circuit breaker, shunt trip abnormal	1. Power off and let it sit for 5 minutes, then restart to see if the fault persists; 2. Observe the blind-mate connectors at the bottom of the PACK and PCU, check if the communication pins are loose or bent;
	MCU self-test failure	Upgrade the software, restart the battery. If the problem persists after restart, please contact the after-sales service center.
	1. Software version too low or BMS board damaged 2. Large number of parallel inverters, excessive inrush current during battery pre-charge	1. Upgrade the software and observe if the fault persists. 2. In parallel operation, black-start the battery first before starting the inverters.
	MCU internal fault	Upgrade the software, restart the battery. This usually indicates MCU or external component damage. If the problem persists after restart, please contact the after-sales service center.

Fault Name	Fault Cause	Troubleshooting Suggestions
	Total control current greater than the specified threshold	<ol style="list-style-type: none"> <li>1. Power off and let it sit for 5 minutes, then restart to see if the fault persists;</li> <li>2. Check if the inverter power setting is too high, causing it to exceed the bus load;</li> </ol>
	Inconsistent cells in parallel battery clusters	Confirm if the cells in the parallel battery clusters are consistent.
	Reverse polarity connection of parallel battery clusters	Check if the positive and negative terminals of the parallel battery clusters are reversed.
	Severe overtemperature, overvoltage, etc., triggering the fire protection system	Contact the after-sales service center.
Air Conditioner Failure	Air conditioner abnormal failure	Try restarting the system. If the fault is not resolved, please contact the after-sales service center.
	Cabinet door not closed	Check if the cabinet door is properly closed
	Supply voltage too high	Confirm if the supply voltage meets the air conditioner input voltage requirements. Confirm compliance before reapplying power.
	Insufficient supply voltage	
	No voltage input	
	Unstable supply voltage	

Fault Name	Fault Cause	Troubleshooting Suggestions
	Compressor voltage unstable	Try restarting the system. If the fault is not resolved, please contact the after-sales service center.
	Sensor poor contact or damaged	
	Air conditioner fan abnormal	
BMS1 Other Fault 2 (Residential Storage)	DCDC internal voltage or current abnormal	Refer to specific DC fault content.
	DCDC overload or heatsink temperature too high, etc.	
	Cell sensing abnormal or inconsistent aging levels	Please contact the after-sales service center.
	Fan operation not executed normally	Please contact the after-sales service center.
	Output terminal screw loose or poor contact	<ol style="list-style-type: none"> <li>1. Power off the battery, check the wiring and output terminal screw condition.</li> <li>2. After confirmation, restart the battery and observe if the fault persists. If it persists, please contact the after-sales service center.</li> </ol>
Battery used for too long or cells severely damaged	Please contact the after-sales service center to replace the pack.	

Fault Name	Fault Cause	Troubleshooting Suggestions
	1. Software version too low or BMS board damaged 2. Large number of parallel inverters, excessive inrush current during battery pre-charge	1. Upgrade the software and observe if the fault persists. 2. In parallel operation, black-start the battery first before starting the inverters.
	Heating film damaged	Please contact the after-sales service center.
	Heating film three-terminal fuse blown, heating function unavailable	Please contact the after-sales service center.
	Software model, cell type, hardware model mismatch	Check if the software model, SN number, cell type, and hardware model are consistent. If not, please contact the after-sales service center.
	Thermal management board communication line break	1. Power off and let it sit for 5 minutes, then restart to see if the fault persists; 2. If the fault does not recover, contact after-sales to replace the pack.
	Pack fan fault signal triggered	
DCDC Fault	Output terminal voltage too high	Check the output terminal voltage. If the output terminal voltage is normal and the fault does not clear itself after restarting the battery, please contact the after-sales service center.

Fault Name	Fault Cause	Troubleshooting Suggestions
	DCDC module detects battery voltage exceeding maximum charging voltage	Stop charging, discharge to below 90% SOC or let it sit for 2 hours. If ineffective and the fault persists after restart, please contact the after-sales service center.
	Heatsink temperature too high	Let the battery sit for 1 hour for the heatsink temperature to drop. If ineffective and the fault persists after restart, please contact the after-sales service center.
	Battery discharge current too high	Check if the load exceeds the battery's discharge capability. Turn off the load or stop the PCS operation for 60s. If ineffective and the fault persists after restart, please contact the after-sales service center.
	Output terminal power cable harness positive/negative reversed with parallel battery clusters or PCS	Turn off the battery manual switch, check if the output terminal wiring is correct, and restart the battery.
	Output power relay cannot close	Check if the output terminal wiring is correct and if there is a short circuit. If ineffective and the fault persists after restart, please contact the after-sales service center.
	Power device temperature too high	Let the battery sit for 1 hour for the internal power device temperature to drop. If ineffective and the fault persists after restart, please contact the after-sales service center.
	Relay welded/stuck	If the fault persists after restart, please contact the after-sales service center.

Fault Name	Fault Cause	Troubleshooting Suggestions
Battery Rack Circulating Current Failure	<ol style="list-style-type: none"> <li>1. Cell imbalance</li> <li>2. First power-on without full charge calibration</li> </ol>	Record the fault phenomenon, restart the battery, wait a few minutes, and confirm if the fault disappears. If the problem persists after restart, please contact the after-sales service center.
BMS1 Other Fault 3 (Large-scale Storage)	Communication abnormal with Linux module	<ol style="list-style-type: none"> <li>1. Check if the communication cable connection is normal.</li> <li>2. Upgrade the software, restart the battery and observe if the fault persists. If it persists, please contact the after-sales service center.</li> </ol>
	Cell temperature rise too fast	Cell abnormal, contact after-sales to replace the pack.
	SOC below 10%	Charge the battery.
	SN writing does not comply with rules	Check if the SN number of digits is normal. If abnormal, please contact the after-sales service center.
	<ol style="list-style-type: none"> <li>1. Communication abnormal within battery cluster daisy chain</li> <li>2. Inconsistent cell aging levels between battery clusters</li> </ol>	<ol style="list-style-type: none"> <li>1. Check the pack contact condition within a single battery cluster.</li> <li>2. Confirm the usage status of each cluster battery, such as cumulative charge/discharge capacity, cycle count, etc.</li> <li>3. Please contact the after-sales service center.</li> </ol>
	High humidity inside pack	-
	Fuse blown	Contact after-sales to replace the pack.
	Battery low power	Charge the battery.
	Circuit breaker abnormal	Contact after-sales to replace the pack.

<b>Fault Name</b>	<b>Fault Cause</b>	<b>Troubleshooting Suggestions</b>
BMS1 Other Fault 4 (Large-scale Storage)	External device abnormal	Contact after-sales to replace the pack.
Contactor Failure 1	-	-
Contactor Failure 2	-	-
Overload Protection (Ksic)	Sustained overload (exceeding 690KVA) for 10s	Please contact the after-sales service center.
Overload Protection (Smart Port)	Sustained overload (exceeding 690KVA) for 10s	Please contact the after-sales service center.
Overcurrent Protection (Ksic)	-	-
Overcurrent Protection (Smart Port)	-	-
Master AC On Meter Comm Error	1. The meter may not be connected to the master unit 2. The meter communication cable may be loose	1. Check if the meter is connected to the master unit 2. Check if the meter communication cable is loose
Parallel Slave Meter Error	Meter connected to slave unit	Set the machine connected to the meter as the master unit

Fault Name	Fault Cause	Troubleshooting Suggestions
Slave AC On Timeout with Master	1. Slave address setting error 2. Slave communication cable loose	1. Check for duplicate slave addresses 2. Check if the parallel communication cable is loose

### 8.5.2.3 Battery Fault

- **Lynx C Series 60kWh Commercial and Industrial Battery System**

No.	Fault Name	Possible Cause	Troubleshooting
1	Battery Over Voltage	Charging continues when the battery is fully charged	Stop charging. If it does not recover automatically, please contact professional technicians to restart the system.
2	Battery Undervoltage	Discharging continues when the battery is fully discharged	Stop discharging. If it does not recover automatically, please contact professional technicians to restart the system.
3	Battery Overcurrent	Current exceeds the system's maximum current during charging or discharging	Reduce power. If it does not recover automatically, please contact professional technicians to restart the system.
4	Battery Overtemperature	Temperature is too high during charging or discharging	Perform cooling treatment. If it does not recover automatically, please contact professional technicians to restart the system.
5	Battery Undertemperature	Temperature is too low during charging or discharging	Perform heating treatment. If it does not recover automatically, please contact professional technicians to restart the system.

No.	Fault Name	Possible Cause	Troubleshooting
6	Battery Terminal Overtemperature	Temperature is too high during charging or discharging	Perform cooling treatment. If it does not recover automatically, please contact professional technicians to restart the system.
7	Battery Imbalance	Excessive temperature or voltage difference between individual cells	Stop charging/discharging until temperature differences recover; perform balancing if voltage difference is excessive.
8	Insulation Resistance	System insulation resistance is low	Check grounding conditions
9	Precharge Failure	Precharge circuit component failure	Check precharge circuit components
10	Harness Fault	Abnormal voltage, temperature, or current harness	Check the corresponding harness
11	Relay Open Circuit	Relay Failure	Replace the relay
12	Relay Short Circuit	Relay Failure	Replace the relay
13	Cluster Parallel Fault	Slave cluster communication loss	Check the reliability of master-slave harness connections
14	PCS Comm Loss	Abnormal communication harness with PCS	Check the reliability of harness connections
15	BMU Communication Fault	Abnormal communication harness between BCU and BMU	Check the reliability of harness connections
16	Circuit Breaker Sticking Fault	Molded case circuit breaker failure	Replace the molded case circuit breaker
17	Fire Protection System Triggered	Internal thermal runaway in the system	Please contact the after-sales service center.

No.	Fault Name	Possible Cause	Troubleshooting
18	Air Conditioner Failure	Abnormal fault occurred within the air conditioning system	Please contact the after-sales service center.

• **BAT-S Series 15.3-56.3kWh High-Voltage Battery**

No.	Fault Name	Possible Causes	Troubleshooting
1	Charging Overvoltage <sup>2</sup>	<ul style="list-style-type: none"> <li>Cell voltage/total voltage too high</li> <li>Voltage sensing line abnormal</li> </ul>	<ol style="list-style-type: none"> <li>Power off and let the system rest for 5 minutes, then restart to see if the fault persists;</li> <li>If the fault is not cleared, contact GoodWe after-sales service.</li> </ol>
2	Charging Overvoltage <sup>3</sup>	<ul style="list-style-type: none"> <li>Cell voltage/total voltage too high</li> <li>Voltage sensing line abnormal</li> </ul>	<ol style="list-style-type: none"> <li>Power off and let the system rest for 5 minutes, then restart to see if the fault persists;</li> <li>If the fault is not cleared, contact GoodWe after-sales service.</li> </ol>
3	Discharge Undervoltage <sup>3</sup>	<ul style="list-style-type: none"> <li>Cell voltage/total voltage too low</li> <li>Voltage sensing line abnormal</li> </ul>	<ol style="list-style-type: none"> <li>Power off and let the system rest for 5 minutes, then restart to see if the fault persists;</li> <li>Check the inverter's working status to see if it is failing to charge the battery due to issues like working mode. Try charging the battery via the inverter and observe if the fault clears.</li> <li>If the fault is not cleared, contact GoodWe after-sales service.</li> </ol>

No.	Fault Name	Possible Causes	Troubleshooting
4	Discharge Undervoltage2	<ul style="list-style-type: none"> <li>• Cell voltage/total voltage too low</li> <li>• Voltage sensing line abnormal</li> </ul>	<ol style="list-style-type: none"> <li>1. Power off and let the system rest for 5 minutes, then restart to see if the fault persists;</li> <li>2. Check the inverter's working status to see if it is failing to charge the battery due to issues like working mode. Try charging the battery via the inverter and observe if the fault clears.</li> <li>3. If the fault is not cleared, contact GoodWe after-sales service.</li> </ol>
5	Cell Overvoltage2	<ul style="list-style-type: none"> <li>• Cell voltage/total voltage too high</li> <li>• Voltage sensing line abnormal</li> </ul>	<ol style="list-style-type: none"> <li>1. Power off and let the system rest for 5 minutes, then restart to see if the fault persists;</li> </ol> <p>If the fault is not cleared, contact GoodWe after-sales service.</p>
6	Cell Undervoltage2	Cell undervoltage	<ol style="list-style-type: none"> <li>1. Power off and let the system rest for 5 minutes, then restart to see if the fault persists;</li> <li>2. Check the inverter's working status to see if it is failing to charge the battery due to issues like working mode. Try charging the battery via the inverter and observe if the fault clears.</li> <li>3. If the fault is not cleared, contact GoodWe after-sales service.</li> </ol>

No.	Fault Name	Possible Causes	Troubleshooting
7	Significant Cell Voltage Variation <sup>2</sup>	Significant cell voltage variation	<ol style="list-style-type: none"> <li>1. Restart the battery and wait for 12 hours.</li> <li>2. If the fault is not cleared, contact GoodWe after-sales service.</li> </ol>
8	Charging Overcurrent <sup>2</sup>	<ul style="list-style-type: none"> <li>• Charging current too high, battery current limiting abnormal: Sudden change in temperature and voltage values</li> <li>• Inverter response abnormal</li> </ul>	<ol style="list-style-type: none"> <li>1. Power off and let the system rest for 5 minutes, then restart to see if the fault persists;</li> <li>2. Check if the inverter power setting is too high, exceeding the battery's rated operating current;</li> <li>3. If the fault is not cleared, contact GoodWe after-sales service.</li> </ol>
9	Discharge Overcurrent <sup>2</sup>	<ul style="list-style-type: none"> <li>• Discharge current too high, battery current limiting abnormal: Sudden change in temperature and SOC values</li> <li>• Inverter response abnormal</li> </ul>	
10	Battery Cell High Temperature <sup>2</sup>	<ul style="list-style-type: none"> <li>• Cell temperature too high</li> <li>• Temperature sensor abnormal</li> </ul>	<ol style="list-style-type: none"> <li>1. Power off and let the system rest for 30 minutes, then restart to see if the fault persists;</li> <li>2. If the fault is not cleared, contact GoodWe after-sales service.</li> </ol>

No.	Fault Name	Possible Causes	Troubleshooting
11	Battery Cell Low Temperature2	<ul style="list-style-type: none"> <li>• Ambient temperature too low</li> <li>• Temperature sensor abnormal</li> </ul>	<ol style="list-style-type: none"> <li>1. Power off and let the system rest for 30 minutes, then restart to see if the fault persists;</li> <li>2. If the fault is not cleared, contact GoodWe after-sales service.</li> </ol>
12	Charging Overtemperature2	<ul style="list-style-type: none"> <li>• Cell temperature too high</li> <li>• Temperature sensor abnormal</li> </ul>	<ol style="list-style-type: none"> <li>1. Power off and let the system rest for 30 minutes; then restart to see if the fault persists;</li> <li>2. If the fault is not cleared, contact GoodWe after-sales service.</li> </ol>
13	Charging Low Temperature2	<ul style="list-style-type: none"> <li>• Ambient temperature too low</li> <li>• Temperature sensor abnormal</li> </ul>	<ol style="list-style-type: none"> <li>1. Power off and let the system rest for 30 minutes; then restart to see if the fault persists;</li> <li>2. If the fault is not cleared, contact GoodWe after-sales service.</li> </ol>
14	Discharge Overtemperature2	<ul style="list-style-type: none"> <li>• Cell temperature too high</li> <li>• Temperature sensor abnormal</li> </ul>	<ol style="list-style-type: none"> <li>1. Power off and let the system rest for 30 minutes; then restart to see if the fault persists;</li> <li>2. If the fault is not cleared, contact GoodWe after-sales service.</li> </ol>
15	Discharge Low Temperature2	<ul style="list-style-type: none"> <li>• Ambient temperature too low</li> <li>• Temperature sensor abnormal</li> </ul>	<ol style="list-style-type: none"> <li>1. Power off and let the system rest for 30 minutes; then restart to see if the fault persists;</li> <li>2. If the fault is not cleared, contact GoodWe after-sales service.</li> </ol>

No.	Fault Name	Possible Causes	Troubleshooting
16	Significant Cell Temperature Variation <sup>2</sup>	Significant cell temperature variation	<ol style="list-style-type: none"> <li>1. Power off and let the system rest for 30 minutes; then restart to see if the fault persists;</li> <li>2. If the fault is not cleared, contact GoodWe after-sales service.</li> </ol>
17	Precharge Disabled	Precharge MOS closing failure	<ol style="list-style-type: none"> <li>1. Power off and let the system rest for 5 minutes, then restart to see if the fault persists;</li> <li>2. If the fault is not cleared, contact GoodWe after-sales service.</li> </ol>
18	Battery Tripping	Battery Trip	<ol style="list-style-type: none"> <li>1. Let the system rest for 10 minutes, then re-close to recover;</li> <li>2. If the fault is not cleared, contact GoodWe after-sales service.</li> </ol>
19	Battery and Inverter Comm Failure	Battery and Inverter Comm Failure	<ol style="list-style-type: none"> <li>1. Confirm the communication cable wiring sequence and DC cable are correct, and check for continuity.</li> <li>2. Restart the inverter and battery.</li> <li>3. If the fault is not cleared, contact GoodWe after-sales service.</li> </ol>
20	Specific Failures	Battery specific failure	Please contact the after-sales service center.

No.	Fault Name	Possible Causes	Troubleshooting
21	Cluster Parallelization Failure	Slave cluster lost connection Cluster parallelization failure	Check the reliability of the master-slave harness communication connection; Please contact the after-sales service center.
22	Application Software Failure	Software self-test failure	Please contact the after-sales service center.
23	Microelectronic Failure	Electronic component failure	Please contact the after-sales service center.
24	Main Controller Overload	Exceeding power line carrying capacity range	Stop charging. If it does not recover automatically, please contact a professional technician to restart the system.
25	SN Abnormal	Batteries with identical SN exist	Please contact the after-sales service center.
26	Circuit Breaker Abnormal	Molded case circuit breaker abnormal tripping	Replace the molded case circuit breaker.

• **BAT-C Series 61.4-112.6kWh Commercial and Industrial Battery System**

No.	Fault Name	Possible Causes	Troubleshooting
1	Charging Overvoltage <sup>2</sup>	<ul style="list-style-type: none"> <li>Cell voltage/total voltage too high</li> <li>Voltage sampling wire abnormal</li> </ul>	<ol style="list-style-type: none"> <li>Power off and let it sit for 5 minutes, restart and check if the fault persists.</li> <li>If the fault is not cleared, contact GoodWe after-sales service.</li> </ol>

No.	Fault Name	Possible Causes	Troubleshooting
2	Charging Overvoltage <sup>3</sup>	<ul style="list-style-type: none"> <li>• Cell voltage/total voltage too high</li> <li>• Voltage sampling wire abnormal</li> </ul>	<ol style="list-style-type: none"> <li>1. Power off and let it sit for 5 minutes, restart and check if the fault persists.</li> <li>2. If the fault is not cleared, contact GoodWe after-sales service.</li> </ol>
3	Discharge Undervoltage <sup>3</sup>	<ul style="list-style-type: none"> <li>• Cell voltage/total voltage too low</li> <li>• Voltage sampling wire abnormal</li> </ul>	<ol style="list-style-type: none"> <li>1. Power off and let it sit for 5 minutes, restart and check if the fault persists.</li> <li>2. Check the inverter's working status to see if it is not charging the battery due to issues like working mode. Try charging the battery via the inverter and observe if the fault is cleared.</li> <li>3. If the fault is not cleared, contact GoodWe after-sales service.</li> </ol>
4	Discharge Undervoltage <sup>2</sup>	<ul style="list-style-type: none"> <li>• Cell voltage/total voltage too low</li> <li>• Voltage sampling wire abnormal</li> </ul>	<ol style="list-style-type: none"> <li>1. Power off and let it sit for 5 minutes, restart and check if the fault persists.</li> <li>2. Check the inverter's working status to see if it is not charging the battery due to issues like working mode. Try charging the battery via the inverter and observe if the fault is cleared.</li> <li>3. If the fault is not cleared, contact GoodWe after-sales service.</li> </ol>

No.	Fault Name	Possible Causes	Troubleshooting
5	Cell Overvoltage2	<ul style="list-style-type: none"> <li>• Cell voltage/total voltage too high</li> <li>• Voltage sampling wire abnormal</li> </ul>	<p>1. Power off and let it sit for 5 minutes, restart and check if the fault persists.</p> <p>If the fault is not cleared, contact GoodWe after-sales service.</p>
6	Cell Undervoltage2	Cell undervoltage	<p>1. Power off and let it sit for 5 minutes, restart and check if the fault persists.</p> <p>2. Check the inverter's working status to see if it is not charging the battery due to issues like working mode. Try charging the battery via the inverter and observe if the fault is cleared.</p> <p>3. If the fault is not cleared, contact GoodWe after-sales service.</p>
7	Significant Cell Voltage Variation2	Significant cell voltage variation	<p>1. Restart the battery and wait for 12 hours.</p> <p>2. If the fault is not cleared, contact GoodWe after-sales service.</p>
8	Charging Overcurrent2	<ul style="list-style-type: none"> <li>• Charging current too high, battery current limiting abnormal: sudden changes in temperature and voltage values</li> <li>• Inverter response abnormal</li> </ul>	<p>1. Power off and let it sit for 5 minutes, restart and check if the fault persists.</p> <p>2. Check if the inverter is set to a power level too high, causing it to exceed the battery's rated operating current.</p> <p>3. If the fault is not cleared, contact GoodWe after-sales service.</p>

No.	Fault Name	Possible Causes	Troubleshooting
9	Discharge Overcurrent <sup>2</sup>	<ul style="list-style-type: none"> <li>Discharge current too high, battery current limiting abnormal: sudden changes in temperature and SOC values</li> <li>Inverter response abnormal</li> </ul>	
10	Battery Cell High Temperature <sup>2</sup>	<ul style="list-style-type: none"> <li>Cell temperature too high</li> <li>Temperature sensor abnormal</li> </ul>	<ol style="list-style-type: none"> <li>Power off and let it sit for 30 minutes, restart and check if the fault persists.</li> <li>If the fault is not cleared, contact GoodWe after-sales service.</li> </ol>
11	Battery Cell Low Temperature <sup>2</sup>	<ul style="list-style-type: none"> <li>Ambient temperature too low</li> <li>Temperature sensor abnormal</li> </ul>	<ol style="list-style-type: none"> <li>Power off and let it sit for 30 minutes, restart and check if the fault persists.</li> <li>If the fault is not cleared, contact GoodWe after-sales service.</li> </ol>
12	Charging Overtemperature <sup>2</sup>	<ul style="list-style-type: none"> <li>Cell temperature too high</li> <li>Temperature sensor abnormal</li> </ul>	<ol style="list-style-type: none"> <li>Power off and let it sit for 30 minutes; restart and check if the fault persists.</li> <li>If the fault is not cleared, contact GoodWe after-sales service.</li> </ol>

No.	Fault Name	Possible Causes	Troubleshooting
13	Charging Low Temperature <sup>2</sup>	<ul style="list-style-type: none"> <li>Ambient temperature too low</li> <li>Temperature sensor abnormal</li> </ul>	<ol style="list-style-type: none"> <li>Power off and let it sit for 30 minutes; restart and check if the fault persists.</li> <li>If the fault is not cleared, contact GoodWe after-sales service.</li> </ol>
14	Discharge Overtemperature <sup>2</sup>	<ul style="list-style-type: none"> <li>Cell temperature too high</li> <li>Temperature sensor abnormal</li> </ul>	<ol style="list-style-type: none"> <li>Power off and let it sit for 30 minutes; restart and check if the fault persists.</li> <li>If the fault is not cleared, contact GoodWe after-sales service.</li> </ol>
15	Discharge Low Temperature <sup>2</sup>	<ul style="list-style-type: none"> <li>Ambient temperature too low</li> <li>Temperature sensor abnormal</li> </ul>	<ol style="list-style-type: none"> <li>Power off and let it sit for 30 minutes; restart and check if the fault persists.</li> <li>If the fault is not cleared, contact GoodWe after-sales service.</li> </ol>
16	Significant Cell Temperature Variation <sup>2</sup>	Significant cell temperature variation	<ol style="list-style-type: none"> <li>Power off and let it sit for 30 minutes; restart and check if the fault persists.</li> <li>If the fault is not cleared, contact GoodWe after-sales service.</li> </ol>
17	Precharge Disabled	Precharge MOS closure failure	<ol style="list-style-type: none"> <li>Power off and let it sit for 5 minutes, restart and check if the fault persists.</li> <li>If the fault is not cleared, contact GoodWe after-sales service.</li> </ol>

No.	Fault Name	Possible Causes	Troubleshooting
18	Battery Tripping	Battery Trip	<ol style="list-style-type: none"> <li>1. Let it sit for 10 minutes, then re-close to restore.</li> <li>2. If the fault is not cleared, contact GoodWe after-sales service.</li> </ol>
19	Battery and Inverter Comm Failure	Battery and Inverter Comm Failure	<ol style="list-style-type: none"> <li>1. Confirm the communication wire sequence and DC wires are correct, and that the connections are normal.</li> <li>2. Restart the inverter and battery.</li> <li>3. If the fault is not cleared, contact GoodWe after-sales service.</li> </ol>
20	Specific Failures	Battery specific failure	Please contact the after-sales service center.
21	Parallel Cluster Fault	Slave cluster lost connection Parallel cluster failure	Check the reliability of the master-slave harness communication connection Please contact the after-sales service center.
22	Application Software Fault	Software self-check failure	Please contact the after-sales service center
23	Microelectronics Fault	Electronic component failure	Please contact the after-sales service center
24	Main Control Overload	Exceeds power line load capacity range	Stop charging. If it does not recover automatically, please contact professional technicians to restart the system.
25	SN Abnormal	Batteries with identical SN exist	Please contact the after-sales service center

No.	Fault Name	Possible Causes	Troubleshooting
26	Circuit Breaker Abnormal	Molded case circuit breaker abnormally tripped	Replace the molded case circuit breaker
27	Circuit Breaker Sticking Fault	Molded case circuit breaker fault or auxiliary circuit breaker fault	Replace the molded case circuit breaker or replace the auxiliary circuit breaker
28	Fire Protection System Triggered	System internal thermal runaway or false trigger	Please contact the after-sales service center
29	Air Conditioner Fault	Abnormal fault occurred within the air conditioning system	Please contact the after-sales service center
30	Access Control Fault	Door abnormally opened or access control sensor damaged	Close the door or replace the access control sensor
31	Emergency Stop Triggered	Emergency stop pressed or emergency stop button damaged	Replace the emergency stop button
32	PACK Fan Fault	PACK fan stalled or not working	Replace the corresponding PACK fan

### 8.5.3 Post-Fault Clearance Processing

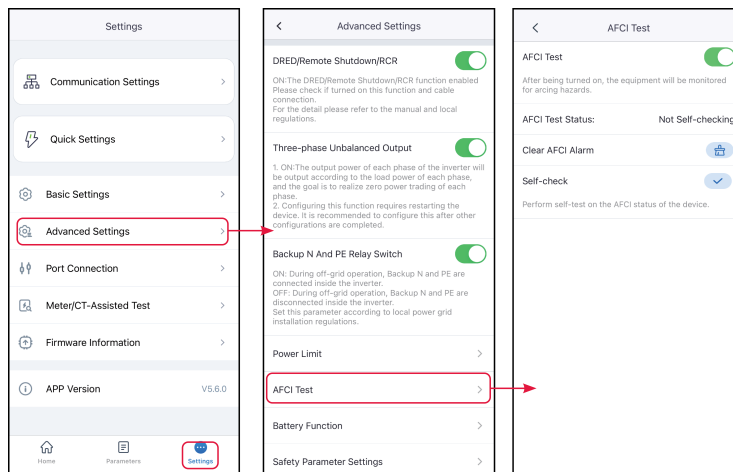
In an energy storage system, after certain faults are handled, post-processing is required for the system to resume normal operation.

### 8.5.3.1 Clear AFCI Fault Warning

Software Used: SolarGo APP

Clear Method:

1. Via [Home] > [Settings] > [Advanced Settings] > [DC Arc Detection].
2. Click the [Clear AFCI Fault Alarm] button.



# 9 technical parameter

## 9.1 Inverter Parameters

Technical Data	GW15K-ET	GW20K-ET	GW25K-ET	GW29.9K-ET	GW30K-ET
<b>Battery Input Data</b>					
Battery Type	Li-Ion	Li-Ion	Li-Ion	Li-Ion	Li-Ion
Nominal Battery Voltage (V)	500	500	500	500	500
Battery voltage range (V)	200~800	200~800	200~800	200~800	200~800
Start-up Voltage (V)	200	200	200	200	200
Number of Battery Input	1	1	2	2	2
Max. Continuous Charging Current (A)	50	50	50×2	50×2	50×2
Max. Continuous Discharging Current (A)	50	50	50×2	50×2	50×2
Max Charge Power (W)	15000	20000	25000	30000	30000
Max Discharge Power (W)	15000	20000	25000	30000	30000
<b>PV String Input Data</b>					
Max. Input Power (W)*1	22500	30000	37500	45000	45000
Max. Input Voltage (V)*2	1000	1000	1000	1000	1000
MPPT Operating Voltage Range (V)	200~850	200~850	200~850	200~850	200~850
MPPT Voltage Range at Nominal Power (V)	400~850	400~850	450~850	450~850	450~850
Start-up Voltage (V)	200	200	200	200	200

<b>Technical Data</b>	<b>GW15K-ET</b>	<b>GW20K-ET</b>	<b>GW25K-ET</b>	<b>GW29.9K-ET</b>	<b>GW30K-ET</b>
Nominal Input Voltage (V)	620	620	620	620	620
Max. Input Current per MPPT (A)	30	30	30	30	30
Max. Short Circuit Current per MPPT (A)	38	38	38	38	38
Max. Backfeed Current to The Array (A)	0	0	0	0	0
Number of MPPT	2	2	3	3	3
Number of Strings per MPPT	2/2	2/2	2/2/2	2/2/2	2/2/2
<b>AC Output Data (On-grid)</b>					
Nominal Output Power (W)	15000	20000	25000	29900	30000
Max. Output Power (W)	15000	20000	25000	29900	30000
Nominal Output Power at 40 °C(W) *14	15000	20000	25000	29900	30000
Max. Output Power at 40 °C (W)*14	15000	20000	25000	29900	30000
Nominal Apparent Power Output to Utility Grid (VA)	15000	20000	25000	29900	30000
Max. Apparent Power Output to Utility Grid (VA)*3 *15	16500	22000	27500	29900	33000
Nominal Apparent Power from Utility Grid(VA)	15000	20000	25000	30000	30000
Max. Apparent Power from Utility Grid (VA) *12	15000	20000	25000	30000	30000

<b>Technical Data</b>	<b>GW15K-ET</b>	<b>GW20K-ET</b>	<b>GW25K-ET</b>	<b>GW29.9K-ET</b>	<b>GW30K-ET</b>
Nominal Output Voltage (V)	380/400, 3L/N/PE	380/400, 3L/N/PE	380/400, 3L/N/PE	380/400, 3L/N/PE	380/400, 3L/N/PE
Output Voltage Range (V)*4	0~300	0~300	0~300	0~300	0~300
Nominal AC Grid Frequency (Hz)	50/60	50/60	50/60	50/60	50/60
AC Grid Frequency Range (Hz)	45~65	45~65	45~65	45~65	45~65
Max. AC Current Output to Utility Grid (A) *11	23.9	31.9	39.9	43.3	47.8
Max. AC Current From Utility Grid (A) *13	22.7	30.3	37.9	45.3	45.5
Nominal AC Current From Utility Grid (A)	21.7 @230V 22.7 @220V	29.0 @230V 30.3 @220V	36.2 @230V 37.9 @220V	43.3 @230V 45.3 @220V	43.5 @230V 45.5 @220V
Max. Output Fault Current (Peak and Duration) (A)	241.5A@ 126ms	241.5A@ 126ms	241.5A@ 126ms	241.5A@ 126ms	241.5A@ 126ms
Inrush Current (Peak and Duration) (A)	264A@5 3us	264A@5 3us	264A@5 3us	264A@5 3us	264A@5 3us
Nominal Output Current (A)*5	21.7	29	36.2	43.3	43.5

Technical Data	GW15K-ET	GW20K-ET	GW25K-ET	GW29.9K-ET	GW30K-ET
Power Factor	~1 (Adjustable from 0.8 leading~0.8 lagging )	~1 (Adjustable from 0.8 leading~0.8 lagging )	~1 (Adjustable from 0.8 leading~0.8 lagging )	~1 (Adjustable from 0.8 leading~0.8 lagging )	~1 (Adjustable from 0.8 leading~0.8 lagging )
Max. Total Harmonic Distortion	≤3.05%	≤3.05%	≤3.05%	≤3.05%	≤3.05%
Maximum Output Overcurrent Protection (A)	94	94	94	94	94
<b>AC Output Data (Back-up)</b>					
Back-up Nominal Apparent Power (VA)	15000	20000	25000	29900	30000
Max. Output Apparent Power without Grid(VA)*6	15,000(18,000@60s , 24,000@3s)	20,000(24,000@60s , 32,000@3s)	25,000(30,000@60s)	30,000(36,000@60s)	30,000(36,000@60s)
Max. Output Apparent Power with Grid (VA)	15000	20000	25000	29900	30000
Nominal Output Current (A)	22.7	30.3	37.9	45.5	45.5
Max. Output Current (A)	22.7(27.3@60s, 36.4@3s)	30.3(36.4@60s, 48.5@3s)	37.9(45.5@60s)	45.5(54.5@60s)	45.5(54.5@60s)
Max. Output Fault Current (Peak and Duration) (A)	94	94	94	94	94

<b>Technical Data</b>	<b>GW15K-ET</b>	<b>GW20K-ET</b>	<b>GW25K-ET</b>	<b>GW29.9K-ET</b>	<b>GW30K-ET</b>
Inrush Current (Peak and Duration) (A)	264@53 us	264@53 us	264@53 us	264@53 us	264@53 us
Maximum Output Overcurrent Protection (A)	94	94	94	94	94
Nominal Output Voltage (V)	380/400	380/400	380/400	380/400	380/400
Nominal Output Frequency (Hz)	50/60	50/60	50/60	50/60	50/60
Output THDv (@Linear Load)	<3%	<3%	<3%	<3%	<3%
<b>Efficiency</b>					
Max. Efficiency	98.0%	98.0%	98.0%	98.0%	98.0%
European Efficiency	97.5%	97.5%	97.5%	97.5%	97.5%
Max. Battery to AC Efficiency	97.5%	97.5%	97.5%	97.5%	97.5%
MPPT Efficiency	99.9%	99.9%	99.9%	99.9%	99.9%
<b>Protection</b>					
PV String Current Monitoring	Integrated	Integrated	Integrated	Integrated	Integrated
PV Insulation Resistance Detection	Integrated	Integrated	Integrated	Integrated	Integrated
Residual Current Monitoring	Integrated	Integrated	Integrated	Integrated	Integrated
PV Reverse Polarity Protection	Integrated	Integrated	Integrated	Integrated	Integrated
Battery Reverse Polarity Protection	Integrated	Integrated	Integrated	Integrated	Integrated

<b>Technical Data</b>	<b>GW15K-ET</b>	<b>GW20K-ET</b>	<b>GW25K-ET</b>	<b>GW29.9K-ET</b>	<b>GW30K-ET</b>
Anti-islanding Protection	Integrated	Integrated	Integrated	Integrated	Integrated
AC Overcurrent Protection	Integrated	Integrated	Integrated	Integrated	Integrated
AC Short Circuit Protection	Integrated	Integrated	Integrated	Integrated	Integrated
AC Overvoltage Protection	Integrated	Integrated	Integrated	Integrated	Integrated
DC Switch*7	Integrated	Integrated	Integrated	Integrated	Integrated
DC Surge Protection	Type II	Type II	Type II	Type II	Type II
AC Surge Protection	Type III	Type III	Type III	Type III	Type III
AFCI*16	Optional	Optional	Optional	Optional	Optional
Rapid Shutdown	Optional	Optional	Optional	Optional	Optional
Remote Shutdown	Integrated	Integrated	Integrated	Integrated	Integrated
<b>General Data</b>					
Operating Temperature Range (°C)	-35~+60	-35~+60	-35~+60	-35~+60	-35~+60
Operating Environment	Outdoor	Outdoor	Outdoor	Outdoor	Outdoor
Relative Humidity	0 ~ 95%	0 ~ 95%	0 ~ 95%	0 ~ 95%	0 ~ 95%
Max. Operating Altitude (m)	4000	4000	4000	4000	4000
Cooling Method	Smart Fan Cooling	Smart Fan Cooling	Smart Fan Cooling	Smart Fan Cooling	Smart Fan Cooling

<b>Technical Data</b>	<b>GW15K-ET</b>	<b>GW20K-ET</b>	<b>GW25K-ET</b>	<b>GW29.9K-ET</b>	<b>GW30K-ET</b>
Display	LED, WLAN+APP	LED, WLAN+APP	LED, WLAN+APP	LED, WLAN+APP	LED, WLAN+APP
Communication with BMS	RS485 / CAN	RS485 / CAN	RS485 / CAN	RS485 / CAN	RS485 / CAN
Communication with Meter	RS485	RS485	RS485	RS485	RS485
Communication with Portal	WiFi+LAN+Bluetooth	WiFi+LAN+Bluetooth	WiFi+LAN+Bluetooth	WiFi+LAN+Bluetooth	WiFi+LAN+Bluetooth
Weight (kg)	48	48	54	54	54
Dimension W×H×D (mm)	520×660×220	520×660×220	520×660×220	520×660×220	520×660×220
Noise Emission (dB)	<45	<45	<45	<60	<60
Topology	Non-isolated	Non-isolated	Non-isolated	Non-isolated	Non-isolated
Self-consumption at Night (W) *8	<15	<15	<15	<15	<15
Ingress Protection Rating	IP66	IP66	IP66	IP66	IP66
DC Connector	Stäubli Electrical Connectors AG	Stäubli Electrical Connectors AG	Stäubli Electrical Connectors AG	Stäubli Electrical Connectors AG	Stäubli Electrical Connectors AG
AC Connector	OT	OT	OT	OT	OT
Environmental Category	4K4H	4K4H	4K4H	4K4H	4K4H
Pollution Degree	III	III	III	III	III
Overvoltage Category	DC II / AC III	DC II / AC III	DC II / AC III	DC II / AC III	DC II / AC III

Technical Data	GW15K-ET	GW20K-ET	GW25K-ET	GW29.9K-ET	GW30K-ET
Protective Class	I	I	I	I	I
Storage Temperature (°C)	-45~+85	-45~+85	-45~+85	-45~+85	-45~+85
The Decisive Voltage Class (DVC)	Battery : C PV: C AC: C Com: A	Battery : C PV: C AC: C Com: A	Battery : C PV: C AC: C Com: A	Battery : C PV: C AC: C Com: A	Battery : C PV: C AC: C Com: A
Mounting Method	Wall Mounted	Wall Mounted	Wall Mounted	Wall Mounted	Wall Mounted
Active Anti-islanding Method	AFDPF + AQDPF *9	AFDPF + AQDPF *9	AFDPF + AQDPF *9	AFDPF + AQDPF *9	AFDPF + AQDPF *9
Type of Electrical Supply System	Three phase Grid	Three phase Grid	Three phase Grid	Three phase Grid	Three phase Grid
Country of Manufacture	China	China	China	China	China

\*1: In Australia, for most PV modules, the max. input power can reach  $2 \cdot P_n$ . For example, the max. input power of the GW15K-ET can reach 30000W. Furthermore, the Max. Input Power is not continuous for 1.5 times the normal power.

\*2: For a 1000V system, the maximum operating voltage is 950V.

\*3: According to local grid regulations.

\*4: Output Voltage Range: phase voltage.

\*5: For a 380V grid, the Nominal Output Current is 22.7A for the GW15K-ET, 30.3A for the GW20K-ET, 37.9A for the GW25K-ET, 45.3A for the GW29.9K-ET, and 45.5A for the GW30K-ET.

\*6: Can only be reached if PV and battery power is sufficient.

\*7: DC Switch: GHX6-55P (for Australia).

\*8: No Backup Output.

\*9: AFDPF: Active Frequency Drift with Positive Feedback, AQDPF: Active Q Drift with Positive Feedback.

- \*10: Not all certifications & standards are listed; check the official website for details.
- \*11: For a 380V grid, the Max. AC Current Output to Utility Grid is 25A for the GW15K-ET, 33.3A for the GW20K-ET, 41.7A for the GW25K-ET, 49.8A for the GW29.9K-ET, and 50A for the GW30K-ET.
- \*12: When the load is connected to the inverter's backup port, the Max. Apparent Power from Utility Grid can reach 22.5kVA for the GW15K-ET, 30kVA for the GW20k-ET, 33kVA for the GW25K-ET, 33kVA for the GW29.9K-ET, and 33kVA for the GW30K-ET respectively.
- \*13: When the load is connected to the inverter's backup port, the Max. AC Current From Utility Grid can reach 34A for the GW15K-ET, 45A for the GW20k-ET, 50A for the GW25K-ET, 50A for the GW29.9K-ET, and 50A for the GW30K-ET respectively.
- \*14: Nominal Output Power at 40 °C(W) and Max. Output Power at 40 °C (W) are for Brazil only.
- \*15: For Austria, the Max. Output Power (W) is 15k for the GW15K-ET, 20k for the GW20K-ET, 25k for the GW25K-ET, 29.9k for the GW29.9K-ET, and 30k for the GW30K-ET.
- \*16: For Brazil, AFCI is integrated.

Technical Data	GW12KL-ET	GW18KL-ET	GW20K-ET	GW30K-ET
<b>Battery Input Data</b>				
Battery Type	Li-Ion	Li-Ion	Li-Ion	Li-Ion
Nominal Battery Voltage (V)	500	500	500	500
Battery Voltage Range (V)	112~650	112~650	200~800	200~800
Start-up Voltage (V)	112	112	180	180
Number of Battery Input	1	2	1	2
Max. Continuous Charging Current (A)	50	50*2	50	50*2
Max. Continuous Discharging Current (A)	50	50*2	50	50*2
Max Charge Power (kW)	12	18	20	30

<b>Technical Data</b>	<b>GW12KL-ET</b>	<b>GW18KL-ET</b>	<b>GW20K-ET</b>	<b>GW30K-ET</b>
Max Discharge Power (kW)	12	18	20	30
<b>PV String Input Data</b>				
Max. Input Power (kW)	24	36	30	45
Max. Input Voltage (V)*1	800	800	1000	1000
MPPT Operating Voltage Range (V)	200~650	200~650	200~850	200~850
MPPT Voltage Range at Nominal Power (V)	260~650	260~650	400~850	450~850
Start-up Voltage (V)	200	200	200	200
Nominal Input Voltage (V)	380	380	620	620
Max. Input Current per MPPT (A)	30	30	30	30
Max. Short Circuit Current per MPPT (A)	38	38	38	38
Max. Backfeed Current to The Array (A)	0	0	0	0
Number of MPPT Trackers	2	3	2	3
Number of Strings per MPPT	2/2	2/2/2	2/2	2/2/2
<b>AC Output Data (On-grid)</b>				
Nominal Output Power (kW)	12	18	20	30
Max. Output Power (kW)	12	18	20	30
Nominal Output Power at 40 °C(kW) *8	12	18	20	30

<b>Technical Data</b>	<b>GW12KL-ET</b>	<b>GW18KL-ET</b>	<b>GW20K-ET</b>	<b>GW30K-ET</b>
Max. Output Power at 40 °C (kW)*8	12	18	20	30
Nominal Apparent Power Output to Utility Grid (kVA)	12	18	20	30
Max. Apparent Power Output to Utility Grid (kVA)	13.2	19.8	22	33
Nominal Apparent Power from Utility Grid(kVA)	12	18	20	30
Max. Apparent Power from Utility Grid (kVA) *6	12	18	20	30
Nominal Output Voltage (V)	220, 3L/N/PE	220, 3L/N/PE	380, 3L/N/PE	380, 3L/N/PE
Output Voltage Range (V)*2	0~165	0~165	0~300	0~300
Nominal AC Grid Frequency (Hz)	60	60	60	60
AC Grid Frequency Range (Hz)	55~65	55~65	45~65	45~65
Max. AC Current Output to Utility Grid (A)	34.6	52	33.3	50
Max. AC Current From Utility Grid (A) *7	31.5	47	30.3	45.5
Nominal AC Current From Utility Grid (A)	31.5	47	30.3	45.5
Max. Output Fault Current (Peak and Duration) (A)	241.5A@126 ms	241.5A@126 ms	241.5A@126 ms	241.5A@126 ms
Inrush Current (Peak and Duration) (A)	264A@53us	264A@53us	264A@53us	264A@53us

<b>Technical Data</b>	<b>GW12KL-ET</b>	<b>GW18KL-ET</b>	<b>GW20K-ET</b>	<b>GW30K-ET</b>
Nominal Output Current (A)	31.5	47	30.3	45.5
Power Factor	~1 (Adjustable from 0.8 leading~0.8 lagging)	~1 (Adjustable from 0.8 leading~0.8 lagging)	~1 (Adjustable from 0.8 leading~0.8 lagging)	~1 (Adjustable from 0.8 leading~0.8 lagging)
Max. Total Harmonic Distortion	<3%	<3%	<3%	<3%
Maximum Output Overcurrent Protection (A)	94	94	94	94
<b>AC Output Data (Back-up)</b>				
Back-up Nominal Apparent Power (kVA)	12	18	20	30
Max. Output Apparent Power without Grid(kVA)*3	12.0(14.4@60s , 19.2@3s)	18.0(21.6@60s)	20.0(24.0@60s , 32.0@3s)	30.0(36.0@60s)
Max. Output Apparent Power with Grid (kVA)	12	18	20	30
Nominal Output Current (A)	31.5	47	30.3	45.5
Max. Output Current (A)	31.5(37.8@60s, 50.4@3s)	47(56.4@60s)	30.3(36.4@60s, 48.5@3s)	45.5(54.5@60s)
Max. Output Fault Current (Peak and Duration) (A)	94	94	94	94
Inrush Current (Peak and Duration) (A)	<a href="#"><u>264@53us</u></a>	<a href="#"><u>264@53us</u></a>	<a href="#"><u>264@53us</u></a>	<a href="#"><u>264@53us</u></a>

<b>Technical Data</b>	<b>GW12KL-ET</b>	<b>GW18KL-ET</b>	<b>GW20K-ET</b>	<b>GW30K-ET</b>
Maximum Output Overcurrent Protection (A)	94	94	94	94
Nominal Output Voltage (V)	220, 3L/N/PE	220, 3L/N/PE	380, 3L/N/PE	380, 3L/N/PE
Nominal Output Frequency (Hz)	60	60	60	60
Output THDv (@Linear Load)	<3%	<3%	<3%	<3%
Switching from Grid Connected Mode to Standalone Mode	20ms	20ms	20ms	20ms
Switching from standalone mode to Grid connected mode	20ms	20ms	20ms	20ms
<b>Efficiency</b>				
Max. Efficiency	98.0%	98.0%	98.0%	98.0%
European Efficiency	97.5%	97.5%	97.5%	97.5%
Max. Battery to AC Efficiency	97.5%	97.5%	97.5%	97.5%
<b>Protection</b>				
PV String Current Monitoring	Integrated	Integrated	Integrated	Integrated
PV Insulation Resistance Detection	Integrated	Integrated	Integrated	Integrated
Residual Current Monitoring	Integrated	Integrated	Integrated	Integrated

<b>Technical Data</b>	<b>GW12KL-ET</b>	<b>GW18KL-ET</b>	<b>GW20K-ET</b>	<b>GW30K-ET</b>
PV Reverse Polarity Protection	Integrated	Integrated	Integrated	Integrated
Battery Reverse Polarity Protection	Integrated	Integrated	Integrated	Integrated
Anti-islanding Protection	Integrated	Integrated	Integrated	Integrated
AC Overcurrent Protection	Integrated	Integrated	Integrated	Integrated
AC Short Circuit Protection	Integrated	Integrated	Integrated	Integrated
AC Overvoltage Protection	Integrated	Integrated	Integrated	Integrated
DC Switch	Integrated	Integrated	Integrated	Integrated
DC Surge Protection	Type II	Type II	Type II	Type II
AC Surge Protection	Type III	Type III	Type III	Type III
AFCI	Integrated	Integrated	Integrated	Integrated
Rapid Shutdown	Optional	Optional	Optional	Optional
Remote Shutdown	Integrated	Integrated	Integrated	Integrated
<b>General Data</b>				
Operating Temperature Range (°C)	-35~+60	-35~+60	-35~+60	-35~+60
Storage Temperature (°C)	-45~+85	-45~+85	-45~+85	-45~+85
Relative Humidity	0 ~ 95%	0 ~ 95%	0 ~ 95%	0 ~ 95%
Max. Operating Altitude (m)	4000	4000	4000	4000
Cooling Method	Smart Fan Cooling	Smart Fan Cooling	Smart Fan Cooling	Smart Fan Cooling

<b>Technical Data</b>	<b>GW12KL-ET</b>	<b>GW18KL-ET</b>	<b>GW20K-ET</b>	<b>GW30K-ET</b>
User Interface	LED, WLAN+APP	LED, WLAN+APP	LED, WLAN+APP	LED, WLAN+APP
Communication with BMS	RS485 / CAN	RS485 / CAN	RS485 / CAN	RS485 / CAN
Communication	RS485, WiFi+LAN+B luetooth, 4G+Bluetoo th(Optional)	RS485, WiFi+LAN+B luetooth, 4G+Bluetoo th(Optional)	RS485, WiFi+LAN+B luetooth, 4G+Bluetoo th(Optional)	RS485, WiFi+LAN+B luetooth, 4G+Bluetoo th(Optional)
Communication Protocols	Modbus- RTU (SunSpec Compliant), Modbus- TCP	Modbus- RTU (SunSpec Compliant), Modbus- TCP	Modbus- RTU (SunSpec Compliant), Modbus- TCP	Modbus- RTU (SunSpec Compliant), Modbus- TCP
Weight (kg)	48	54	48	54
Dimension W×H×D (mm)	520×660×22 0	520×660×22 0	520×660×22 0	520×660×22 0
Noise Emission (dB)	<45	<60	<45	<60
Topology	Non- isolated	Non- isolated	Non- isolated	Non- isolated
Self-consumption at Night (W) *4	<15	<15	<15	<15
Ingress Protection Rating	IP66	IP66	IP66	IP66
Anti-corrosion Class	C4	C4	C4	C4
DC Connector	MC4	MC4	MC4	MC4
AC Connector	OT	OT	OT	OT
Environmental Category	4K4H	4K4H	4K4H	4K4H
Pollution Degree	III	III	III	III

Technical Data	GW12KL-ET	GW18KL-ET	GW20K-ET	GW30K-ET
Overvoltage Category	DC II / AC III	DC II / AC III	DC II / AC III	DC II / AC III
Protective Class	I	I	I	I
The Decisive Voltage Class (DVC)	Battery: C PV: C AC: C Com: A	Battery: C PV: C AC: C Com: A	Battery: C PV: C AC: C Com: A	Battery: C PV: C AC: C Com: A
Mounting Method	Wall Mounted	Wall Mounted	Wall Mounted	Wall Mounted
Active Anti-islanding Method	FDPF + AQDPF *5	FDPF + AQDPF *5	AFDPF + AQDPF *5	AFDPF + AQDPF *5
Type of Electrical Supply System	Three phase Grid	Three phase Grid	Three phase Grid	Three phase Grid
Country of Manufacture	China	China	China	China

\*1: For a 1000V system, the maximum operating voltage is 950V.

\*2: Output Voltage Range: phase voltage.

\*3: Can only be reached if PV and battery power is sufficient.

\*4: No Backup Output.

\*5: AFDPF: Active Frequency Drift with Positive Feedback, AQDPF: Active Q Drift with Positive Feedback.

\*6: When the load is connected to the inverter's backup port, the Max. Apparent Power from Utility Grid can reach 18kVA for the GW12KL-ET, 19.8kVA for the GW18KL-ET, 30kVA for the GW20k-ET, and 33kVA for the GW30K-ET respectively.

\*7: When the load is connected to the inverter's backup port, the Max. AC Current From Utility Grid can reach 47.2 A for the GW12KL-ET and 52A for the GW18KL-ET; and can reach 45A for the GW20k-ET and 50A for the GW30K-ET respectively.

\*8: Nominal Output Power at 40 °C(W) and Max. Output Power at 40 °C (W) are for Brazil only.

### 9.3 Smart Meter Technical Data

### 9.3.1 GM330

technical parameter		GM330
Measuring Range	Supported Grid Type	Three-phase, split-phase, single-phase
	Voltage Range L-L (Vac)	172~817
	Voltage Range L-N (Vac)	100~472
	Nominal Frequency (Hz)	50/60
	CT ratio	nA:5A
Communication Parameter	Communication Method	RS485
	Communication Distance (m/ft)	1000/3280
Accuracy Parameter	voltage/current	Class 0.5
	Active Energy	Class 0.5
	Reactive Energy	Class 1
General Parameter	Dimensions (WxHxD mm/in)	72x85x72/2.83x3.35x2.83
	Housing	4-module
	Weight (g/lb)	240/0.53
	Mounting Method	DIN rail
	User Interface	4 LEDs, Reset button
	Power Consumption (W)	≤5
Environmental Parameter	IP Rating	IP20
	Operating Temperature Range (°C/°F)	-30~+70/-22~+158
	Storage Temperature Range (°C/°F)	-30~70/-22~+158
	Relative Humidity (non-condensing)	0~95%
	Max. Operating Altitude (m/ft)	3000/9842
Certification Parameter	Certification	UL1741/ANSI

### 9.3.2 GM3000

Technical Parameter		GM3000
Application		Three-phase
Voltage	Nominal Voltage	3L+N/400V
	Voltage Range	100V~240V
	Frequency	50Hz/60Hz
Current	Rated Current	CT in: 120A/40mA;
	Current Range	0.48A~120A
Power Consumption		<3W
Data Detection		Voltage/Current/Active Power/Reactive Power/Power Factor/Frequency
Energy Calculation		Active/Reactive Power
Accuracy	Voltage/Current	Class I
	Active	Class I
	Reactive	Class II
Communication		RS485 (Max. Baud Rate 9600/ModBus Protocol/Max. Cable Length 100m)
Display		LED, USB, Reset Button
Device	Dimensions (L x W x H mm)	36 x 85 x 66.5
	Weight (g)	450
	Ingress Protection Rating	IP20(Indoor)
	Mounting Method	Back Mounting Plate Installation
Operating Temperature		-25 ~ +60° C
Storage Temperature		-25 ~ +60° C
Humidity		<95% Non-condensing
Operating Altitude(m)		< 2000m
Safe Service Life (Years)		≥25

### 9.3.3 GMK330

<b>model</b>	<b>GMK330</b>
<b>Measurement Range</b>	
Supported Grid Type	1P2W/3P3W/3P4W
Operating voltage (Vac)*	3P4W: 90~264 L-N 3P3W: 90~264 L-L
Frequency (Hz)	50/60
CT ratio	120A: 40mA 200A: 50mA*
Number of CTs	3
<b>Accuracy Parameters</b>	
voltage/current	Class 0.5
Active Energy	Class 0.5
Reactive Energy	Class 1
<b>Communication Parameters</b>	
Communication Method	RS485
Communication Distance (m)	1000
<b>General Parameters</b>	
Dimensions (W*H*D mm)	72*85*72
Housing	4-module
Weight (g)	240
Mounting Method	DIN rail
User Interface	4 LEDs, Reset button
Power Consumption (W)	< 5
<b>Environmental Parameters</b>	

<b>model</b>	<b>GMK330</b>
IP Rating	IP20
Operating Temperature Range (°C)	-30-+70
Storage Temperature Range (°C)	-30-+70
Relative Humidity (non-condensing)	0-95%
Max. Operating Altitude (m)	3000

\*Supports 1.1 times voltage input.

\*The standard CT for the meter has been uniformly updated to the 120A:40mA specification. Meters equipped with the 200A:50mA specification CT will no longer be sold after June 2026.

## 9.4 Smart Dongle Technical Data

### 9.4.1 4G Kit-CN-G21

<b>Product Model</b>	<b>4G Kit-CN-G21</b>
Device Management	
Maximum Supported Inverters	1
Power Parameters	
Input Voltage (V)	5
Power Consumption (W)	≤4
Interface	USB
Communication Parameters	
4G/3G/2G	LTE-FDD: B1/B3/B5/B8 LTE-TDD: B34/B39/B40/B41
GNSS Positioning	BeiDou, GPS
Bluetooth	Bluetooth V5.0

<b>Product Model</b>	<b>4G Kit-CN-G21</b>
Mechanical Parameters	
Dimensions (W×H×D mm)	48.3*95.5*32.1
Weight (g)	87
indicator	LED* 2
Mounting Method	Plug and Play
SIM Card Size	Micro sim, 15mm*12mm
Environmental Parameters	
Operating Temperature Range (°C)	-30~+65
Storage Temperature Range (°C)	-40~+70
Relative Humidity	0-100%
IP Rating	IP66
Max. Operating Altitude (m)	4000
Compliance Standards	
Certification	SRRC、CTA

#### 9.4.2 4G Kit-CN-G20

<b>Product Model</b>	<b>4G Kit-CN-G20</b>
Device Management	
Max. Number of Supported Inverters	1
Power Parameters	
Input Voltage (V)	5
Power Consumption (W)	≤4
Interface Type	USB
Communication Parameters	
4G/3G/2G	LTE-FDD: B1/B3/B5/B8 LTE-TDD: B34/B39/B40/B41
GNSS Positioning	/
Bluetooth	Bluetooth V5.0








<b>Product Model</b>	<b>4G Kit-CN-G20</b>
<b>Mechanical Parameters</b>	
Dimensions (Width × Height × Thickness mm)	48.3*95.5*32.1
Weight (g)	87
Indicator	LED* 2
Mounting Method	Plug and Play
SIM Card Size	Micro sim, 15mm*12mm
<b>Environmental Parameters</b>	
Operating Temperature Range (°C)	-30~+65
Storage Temperature Range (°C)	-40~+70
Relative Humidity	0-100%
IP Rating	IP66
Max. Operating Altitude (m)	4000
<b>Standards Met</b>	
Certification	SRRC、CTA

### 9.4.3 WiFi/LAN Kit-20

<b>technical parameter</b>		<b>WiFi/LAN Kit-20</b>
Output Voltage (V)		5
Power Consumption (W)		≤2
Communication Interface		USB
Communication Parameters	Ethernet	10M/100Mbps Auto-negotiation
	Wireless	IEEE 802.11 b/g/n @2.4 GHz
	Bluetooth	Bluetooth V4.2 BR/EDR and Bluetooth LE Standard
Mechanical Parameters	Dimensions (W×H×D mm)	48.3*159.5*32.1
	Weight (g)	82

technical parameter		WiFi/LAN Kit-20
	Ingress Protection Rating	IP65
	Mounting Method	USB Port Plug-in
Operating Temperature Range (°C)		-30~+60
Storage Temperature Range (°C)		-40~+70
Relative Humidity		0-95%
Max. Operating Altitude (m)		4000

#### 9.4.4 Ezlink3000

indicator /silkscreen	Color	Status	Description
Power indicator 	Blue		Blinking = The communication stick is operating normally.
			Off = The communication stick is powered off.
Communi- cation indicator 	Green		Steady on = The communication stick is connected to the server.
			Double flash = The communication stick is not connected to the router.
			Quadruple flash = The communication stick is connected to the router, but not connected to the server.
RELOAD	-	-	<ul style="list-style-type: none"> <li>• Short press for 1-3 seconds to restart the communication stick.</li> <li>• Long press for 6-10 seconds to restore factory settings.</li> </ul> <p>Quick double-click to enable Bluetooth signal (only lasts for 5 minutes).</p>

# 10 Appendix

## 10.1 FAQ


### 10.1.1 How to conduct auxiliary detection for smart meters/CT?

The meter detection function can detect whether the meter CT is connected correctly and the current operating status of the meter and CT.

- Method 1:

1. Go to **[Home]** > **[Settings]** > **[Meter/CT Auxiliary Detection]** to enter the detection page.
2. Click Start Detection, wait for the detection to complete, and then view the detection results.

- Method 2:

1. Click  > **[System Setup]** > **[Quick Setting]** > **[Meter/CT Assisted Test]** to enter the detection page.
2. Click Start Detection, wait for the detection to complete, and then view the detection results.

### 10.1.2 How to Upgrade the Device Version

Through firmware information, you can view or upgrade:

The inverter's DSP version, ARM version, communication module software version, the battery's BMS version, DCDC version, etc.

- **Upgrade Prompt:**

When the user opens the App, an upgrade prompt pops up on the home page. The user can choose whether to upgrade. If upgrade is selected, follow the on-screen instructions to complete the upgrade.

- **Regular Upgrade:**

Navigate through **[Home]** > **[Settings]** > **[Firmware Information]** to enter the firmware information viewing interface.

Tap "Check for Updates". If a new version is available, follow the on-screen instructions to complete the upgrade.

- **Forced Upgrade:**

The App pushes upgrade information. The user must upgrade as prompted; otherwise, the App cannot be used. Follow the on-screen instructions to complete the upgrade.

### **Inverter Software Version Upgrade**

- The inverter supports software upgrade via a USB drive.
- Before using a USB drive to upgrade the device, please contact the after-sales service center to obtain the software upgrade package and upgrade method.

## **10.2 Abbreviations**

<b>Abbreviation</b>	<b>English Description</b>	<b>Chinese Description</b>
Ubatt	Battery Voltage Range	Battery voltage range
Ubatt,r	Nominal Battery Voltage	Nominal battery voltage
Ibatt,max (C/D)	Max. Charging Current Max. Discharging Current	Max. Charging/Discharging Current
EC,R	Rated Energy	Rated Energy
UDCmax	Max.Input Voltage	Max. Input Voltage
UMPP	MPPT Operating Voltage Range	MPPT Voltage Range
IDC,max	Max. Input Current per MPPT	Max. Input Current per MPPT
ISC PV	Max. Short Circuit Current per MPPT	Max. Short Circuit Current per MPPT
PAC,r	Nominal Output Power	Nominal output power
Sr (to grid)	Nominal Apparent Power Output to Utility Grid	Nominal Apparent Power Output to Utility Grid
Smax (to grid)	Max. Apparent Power Output to Utility Grid	Max. Apparent Power Output to Utility Grid
Sr (from grid)	Nominal Apparent Power from Utility Grid	Nominal Apparent Power from Utility Grid
Smax (from grid)	Max. Apparent Power from Utility Grid	Max. Apparent Power from Utility Grid

<b>Abbreviation</b>	<b>English Description</b>	<b>Chinese Description</b>
UAC,r	Nominal Output Voltage	Nominal output voltage
fAC,r	Nominal AC Grid Frequency	Nominal AC Grid Frequency
IAC,max(to grid)	Max. AC Current Output to Utility Grid	Max. AC Current Output to Utility Grid
IAC,max(from grid)	Max. AC Current From Utility Grid	Max. Current from Grid
P.F.	Power Factor	Power Factor
Sr	Back-up Nominal apparent power	Off-grid Nominal Apparent Power
Smax	Max. Output Apparent Power (VA) Max. Output Apparent Power without Grid	Max. Apparent Power to Grid
IAC,max	Max. Output Current	Max. Current to Grid
UAC,r	Nominal Output Voltage	Max. Output Voltage
fAC,r	Nominal Output Frequency	Nominal Output Voltage Frequency
Toperating	Operating Temperature Range	Operating Temperature Range
IDC,max	Max. Input Current	Max. Input Current
UDC	Input Voltage	Input Voltage
UDC,r	DC Power Supply	DC Input
UAC	Power Supply/AC Power Supply	Input Voltage Range/AC Input
UAC,r	Power Supply/Input Voltage Range	Input Voltage Range/AC Input
Toperating	Operating Temperature Range	Operating Temperature Range
Pmax	Max Output Power	Maximum Power
PRF	TX Power	Transmit Power
PD	Power Consumption	Power Consumption
PAC,r	Power Consumption	Power Consumption
F (Hz)	Frequency	Frequency
ISC PV	Max. Input Short Circuit Current	Max. Input Short Circuit Current
Udcmin-Udcmax	Range of input Operating Voltage	Operating Voltage range

<b>Abbreviation</b>	<b>English Description</b>	<b>Chinese Description</b>
UAC,rang(L-N)	Power Supply Input Voltage	Adapter Input Voltage Range
Usys,max	Max System Voltage	Max. System Voltage
Haltitude,max	Max. Operating Altitude	Max. Operating Altitude
PF	Power Factor	Power Factor
THDi	Total Harmonic Distortion of Current	Current Harmonic Distortion
THDv	Total Harmonic Distortion of Voltage	Voltage Harmonic Distortion
C&I	Commercial & Industrial	Commercial & Industrial
SEMS	Smart Energy Management System	Smart Energy Management System
MPPT	Maximum Power Point Tracking	Maximum Power Point Tracking
PID	Potential-Induced Degradation	Potential-Induced Degradation
Voc	Open-Circuit Voltage	open-circuit voltage
Anti PID	Anti-PID	Anti-PID
PID Recovery	PID Recovery	PID Recovery
PLC	Power-line Commucation	Power Line Carrier Communication
Modbus TCP/IP	Modbus Transmission Control / Internet Protocol	Modbus based on TCP/IP
Modbus RTU	Modbus Remote Terminal Unit	Modbus based on serial link
SCR	Short-Circuit Ratio	Short-Circuit Ratio
UPS	Uninterruptable Power Supply	Uninterruptible Power Supply
ECO mode	Economical Mode	TOU Mode
TOU	Time of Use	Time of Use
ESS	Energy Stroage System	energy storage system
PCS	Power Conversion System	Power Conversion System
RSD	Rapid shutdown	Rapid Shutdown
EPO	Emergency Power Off	Emergency Power Off
SPD	Surge Protection Device	Surge Protection
ARC	zero injection/zero export Power Limit / Export Power Limit	Power Limit

Abbreviation	English Description	Chinese Description
DRED	Demand Response Enabling Device	Demand Response Enabling Device
RCR	Ripple Control Receiver	-
AFCI	AFCI	AFCI DC Arc Fault Protection
GFCI	Ground Fault Circuit Interrupter	GFCI
RCMU	Residual Current Monitoring Unit	Residual Current Monitoring Unit
FRT	Fault Ride Through	Fault Ride Through
HVRT	High Voltage Ride Through	High Voltage Ride Through
LVRT	Low Voltage Ride Through	Low Voltage Ride Through
EMS	Energy Management System	Energy Management System
BMS	Battery Management System	Battery Management System
BMU	Battery Measure Unit	Battery Measurement Unit
BCU	Battery Control Unit	Battery Control Unit
SOC	State of Charge	State of Charge
SOH	State of Health	State of Health
SOE	State Of Energy	State of Energy
SOP	State Of Power	State of Power
SOF	State Of Function	State of Function
SOS	State Of Safety	State of Safety
DOD	Depth of discharge	depth of discharge

## 10.3 Explanation of Terms

- **Explanation of Overvoltage Categories**

- **Overvoltage Category I:** Equipment connected to circuits where measures are taken to limit transient overvoltages to a relatively low level.
- **Overvoltage Category II:** Energy-consuming equipment supplied from a fixed electrical distribution installation. This category includes appliances, portable tools, and other household and similar loads. If special requirements for the reliability and suitability of such equipment exist, Overvoltage Category III applies.
- **Overvoltage Category III:** Equipment in fixed electrical distribution installations, where the reliability and suitability of the equipment must meet special requirements. This includes switching devices in fixed installations and industrial equipment permanently connected to fixed electrical distribution

installations.

- **Overvoltage Category IV:** Equipment used at the origin of the electrical distribution installation, including measuring instruments and primary overcurrent protection devices.

• **Explanation of Damp Location Categories**

Environmental Parameters	Level		
	3K3	4K2	4K4H
Temperature Range	0~+40°C	-33~+40°C	-33~+40°C
Humidity Range	5% to 85%	15% to 100%	4% to 100%

• **Explanation of Environmental Categories:**

- **Outdoor Inverter:** Ambient air temperature range -25°C to +60°C, suitable for Pollution Degree 3 environment.
- **Indoor Type II Inverter:** Ambient air temperature range -25°C to +40°C, suitable for Pollution Degree 3 environment.
- **Indoor Type I Inverter:** Ambient air temperature range 0°C to +40°C, suitable for Pollution Degree 2 environment.

• **Explanation of Pollution Degree Categories**

- **Pollution Degree 1:** No pollution or only dry, non-conductive pollution.
- **Pollution Degree 2:** Normally only non-conductive pollution occurs. Temporary conductivity caused by condensation must be considered.
- **Pollution Degree 3:** Conductive pollution occurs, or non-conductive pollution becomes conductive due to condensation.
- **Pollution Degree 4:** Persistent conductive pollution, for example, caused by conductive dust or rain/snow.

## 10.4 Meaning of Battery SN Code

\*\*\*\*\*2388\*\*\*\*\*  
  
 11-14位

LXD10DSC0002

Digits 11-14 of the product SN code represent the production date code.  
The production date in the image above is 2023-08-08.

- Digits 11 and 12 represent the last two digits of the production year, e.g., 2023 is represented by 23;
- Digit 13 represents the production month, e.g., August is represented by 8;  
Details are as follows:

Month	Jan-Sep	Oct	Nov	Dec
Month Code	1~9	A	B	C

- Digit 14 represents the production day, e.g., the 8th is represented by 8;  
Numbers are used preferentially, e.g., 1~9 represent days 1~9, A represents day 10, and so on. The letters I and O are not used to avoid confusion. Details are as follows:

Production Day	1	2	3	4	5	6	7	8	9
Code	1	2	3	4	5	6	7	8	9

Production Date	10	11	12	13	14	15	16	17	18
Code	A	B	C	D	E	F	G	H	J

Production Date	21	22	23	24	25	26	27	28	29
Code	M	N	P	Q	R	S	T	U	V

## 10.5 Safety Regulation Countries

No.	Safety Regulation Name	No.	Safety Regulation Name
Europe			
1	IT-CEI 0-21	56	IE-LV-72A
2	IT-CEI 0-16	57	IE-ESB-C&D (< 110kV)
3	DE LV with PV	58	IE-EirGrid-110kV
4	DE LV without PV	59	PT-D
5	DE-MV	60	EE

No.	Safety Regulation Name	No.	Safety Regulation Name
6	ES-A	61	NO
7	ES-B	62	FI-A
8	ES-C	63	FI-B
9	ES-D	64	FI-C
10	ES-island	65	FI-D
11	BE	66	UA-A1
12	FR-LV	67	UA-A2
13	FR-island-50Hz	68	EN 50549-1
14	FR-island-60Hz	69	EN 50549-2
15	type A-PL_V.1.1	70	DK-West-B-MVHV
16	type B-LV-PL_V.1.1	71	DK-East-B-MVHV
17	type C-PL_V.1.1	72	DK-West-C-MVHV
18	type D-PL_V.1.1	73	DK-East-C-MVHV
19	NL-16/20A	74	DK-West-D-MVHV
20	NL-A	75	DK-East-D-MVHV
21	NL-B	76	FR-Reunion
22	NL-C	77	BE-LV (>30kVA)
23	NL-D	78	BE-HV
24	SE-A	79	CH-B
25	SE MV	80	NI-G99-A
26	SK-A	81	NI-G99-B
27	SK-B	82	NI-G99-C
28	SK-C	83	NI-G99-D
29	HU	84	IE-LV-170kVA
30	CH-A	85	IE-MV&HV-200kVA
31	CY	86	DE-HV
32	GR	87	FR-MV
33	DK-West-A	88	CZ-A1/A2-09

No.	Safety Regulation Name	No.	Safety Regulation Name
34	DK-East-A	89	DE-EHV
35	DK-West-B	90	IE-EirGrid-400KV
36	DK-East-B	91	IE-EirGrid-220KV
37	AT < 1kV	92	IE-EirGrid-66KV
38	AT > 1kV	93	IE-ESB-B
39	BG	94	IE-ESB-D( $\geq 110\text{kV}$ )
40	Czech	95	type B-MV-PL_V.1.1
41	CZ-A1-09	96	GB-G99-A HV
42	CZ-A2-09	97	GB-G99-B LV
43	CZ-B1/B2-09	98	GB-G99-C LV
44	CZ-C	99	UA-B
45	CZ-D	100	UA-C
46	RO-A	101	UA-D
47	RO-B	102	UK-G98
48	RO-D	103	UK-G99-A LV
49	GB-G98	104	UK-G99-B LV
50	GB-G99-A LV	105	UK-G99-C LV
51	GB-G99-B HV	106	CZ-A1
52	GB-G99-C HV	107	UK-A-MV
53	GB-G99-D	108	UK-B-MV
54	NI-G98	109	UK-C-MV
55	IE-LV-16/25A	-	-
<b>Global</b>			
1	60Hz-Default	6	IEC 61727-60Hz

No.	Safety Regulation Name	No.	Safety Regulation Name
2	50Hz-Default	7	Warehouse
3	127Vac-60Hz-Default	8	IEC61727-480Vac-60Hz
4	127Vac-50Hz-Default	9	IEC61727-480Vac-50Hz
5	IEC 61727-50Hz		
<b>Americas</b>			
1	Argentina-220V-LV	38	LUMAPR-2024-220Vac-3P
2	US-208Vac	39	LUMAPR-2024-240Vac-3P
3	US-240Vac	40	Cayman
4	Mexico-220Vac	41	Brazil-220Vac
5	Mexico-440Vac	42	Brazil-208Vac
6	US-480Vac	43	Brazil-230Vac
7	US-208Vac-3P	44	Brazil-240Vac
8	US-220Vac-3P	45	Brazil-254Vac
9	US-240Vac-3P	46	Brazil-127Vac
10	US-CA-208Vac	47	Brazil-ONS
11	US-CA-240Vac	48	Barbados
12	US-CA-480Vac	49	Chile-BT
13	US-CA-208Vac-3P	50	Chile-MT-A
14	US-CA-220Vac-3P	51	Chile MT-B
15	US-CA-240Vac-3P	52	Colombia
16	US-HI-208Vac	53	Colombia<0.25MW-208Vac-1P
17	US-HI-240Vac	54	Colombia<0.25MW-120Vac-3P
18	US-HI-480Vac	55	IEEE 1547-208Vac
19	US-HI-208Vac-3P	56	IEEE 1547-220Vac
20	US-HI-220Vac-3P	57	IEEE 1547-240Vac
21	US-HI-240Vac-3P	58	IEEE 1547-230Vac
22	US-Kauai-208Vac	59	Colombia<0.25MW-127Vac-3P
23	US-Kauai-240Vac	60	Colombia>5MW

No.	Safety Regulation Name	No.	Safety Regulation Name
24	US-Kauai-480Vac	61	Mexico-127V
25	US-Kauai-208Vac-3P	62	Mexico-240V
26	US-Kauai-220Vac-3P	63	US-O&R-208Vac
27	US-Kauai-240Vac-3P	64	US-O&R-240Vac
28	US-ISO-NE-208Vac	65	US-O&R-480Vac
29	US-ISO-NE-240Vac	66	US-O&R-208Vac-3P
30	US-ISO-NE-480Vac	67	US-O&R-220Vac-3P
31	US-ISO-NE-208Vac-3P	68	US-O&R-240Vac-3P
32	US-ISO-NE-220Vac-3P	69	Brazil-277Vac
33	US-ISO-NE-240Vac-3P	70	Chile-BT ≤9MW
34	LUMAPR-2024-208Vac	71	Chile-MT ≤9MW
35	LUMAPR-2024-240Vac	72	Chile > 9MW
36	LUMAPR-2024-480Vac	73	Mexico-277Vac
37	LUMAPR-2024-208Vac-3P		
<b>Oceania</b>			
1	Australia-A	4	Newzealand
2	Australia-B	5	Newzealand:2015
3	Australia-C	6	NZ-GreenGrid
<b>Asia</b>			
1	China A	33	Israel-MV
2	China B	34	Israel-HV
3	China Higher Voltage	35	Vietnam
4	China Highest Voltage	36	Malaysia-LV
5	China Power Station	37	Malaysia-MV
6	China Shandong	38	DEWA-LV
7	China Hebei	39	DEWA-MV

No.	Safety Regulation Name	No.	Safety Regulation Name
8	China PCS	40	Saudi Arabia-220V-LV
9	Taiwan	41	JP-690Vac-50Hz
10	Hong Kong	42	JP-690Vac-60Hz
11	China Northeast	43	Srilanka-MV/HV
12	Thailand-MEA	44	IEC 61727-127Vac-50Hz
13	Thailand-PEA	45	IEC 61727-127Vac-60Hz
14	Mauritius	46	JP-550Vac-50Hz
15	Korea	47	JP-550Vac-60Hz
16	India	48	India-Higher
17	India-CEA	49	JP-220Vac-50Hz
18	Pakistan	50	JP-220Vac-60Hz
19	Philippines	51	Saudi Arabia-127V-LV
20	Philippines-127Vac	52	Srilanka-LV >1MW
21	JP-200Vac-50Hz	53	China-YN
22	JP-200Vac-60Hz	54	GB/T 29319-LV
23	JP-440Vac-50Hz	55	GB/T 29319-MV
24	JP-440Vac-60Hz	56	Philippines -277Vac
25	JP-420Vac-50Hz	57	JP-360Vac-50Hz
26	JP-420Vac-60Hz	58	JP-360Vac-60Hz
27	JP-480Vac-50Hz	59	JP-320Vac-50Hz
28	JP-480Vac-60Hz	60	JP-320Vac-60Hz
29	Srilanka-LV<1MW	61	JP-340Vac-50Hz
30	Singapore	62	JP-340Vac-60Hz
31	Israel-OG	63	JP-380Vac-50Hz
32	Israel-LV	64	JP-380Vac-60Hz
<b>Africa</b>			
1	Mauritius	5	Ghana-LV

No.	Safety Regulation Name	No.	Safety Regulation Name
2	South Africa-LV	6	Ghana-HV
3	South Africa-B-MV	7	South Africa-A3-LV
4	South Africa-C-MV	8	Nigeria

# 11 Contact Details

GoodWe Technologies Co., Ltd.  
No. 90 Zijin Rd., New District, Suzhou, China  
[en.goodwe.com](http://en.goodwe.com)  
service@goodwe.com